

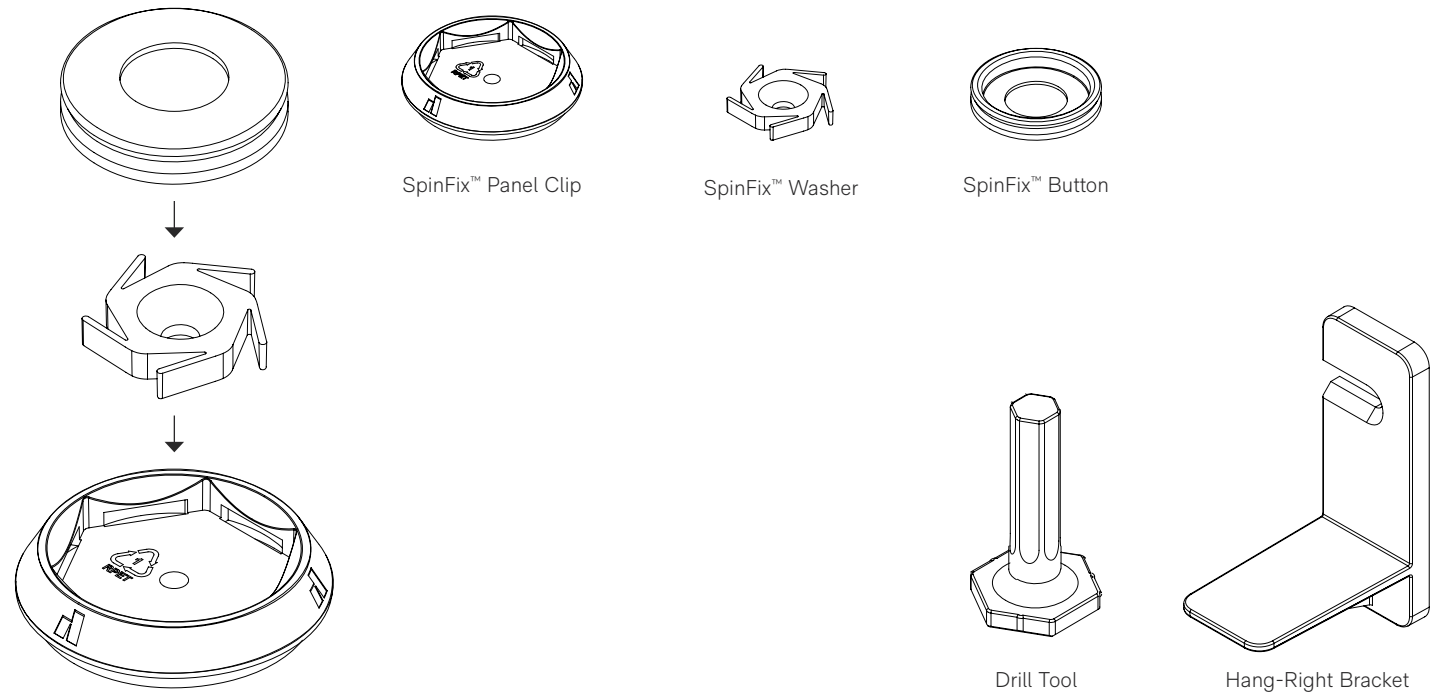

**Product  
overview**

SpinFix™ is an adhesive-free mounting system that uses clips made from recycled PET. This process improves the ease of reuse and recycling at end of life.

**Specification**



**General information**

SpinFix accessories should always be installed in accordance with the below instructions and as per the specification detail. If there is conflicting information, you must seek clarification from all appropriate parties before proceeding.

It is imperative that the installation is planned before cutting and installing any product.



## Install method

### SpinFix—prepping the wall

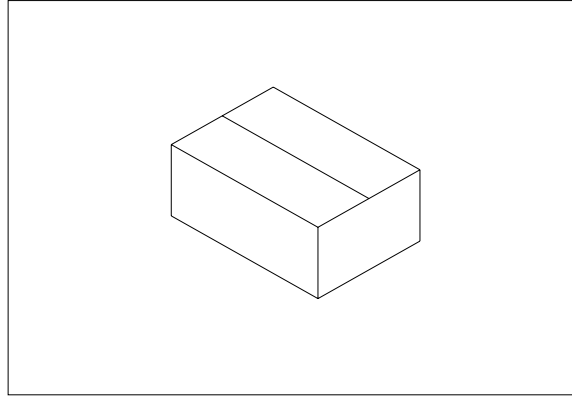

Unbox panels and accessories, check all parts are included and suitable for install.

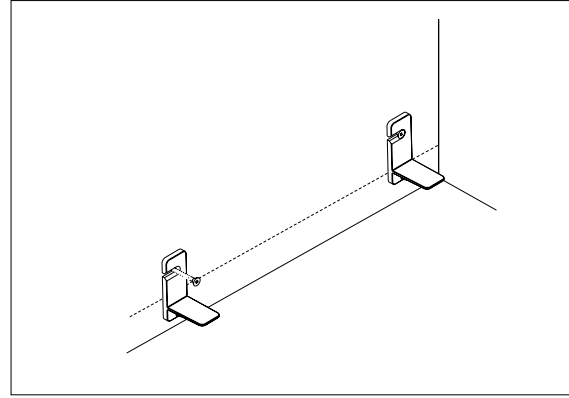

Fix Hang-Right brackets to wall.

- Use laser level to align Hang-Right Brackets where you intend the bottom edge of your panel(s) to sit once installed.
- Use a single screw per Hang-Right Bracket. Do not overtighten as brackets will be removed after installation.
- Not required if you have a skirting board to align to.

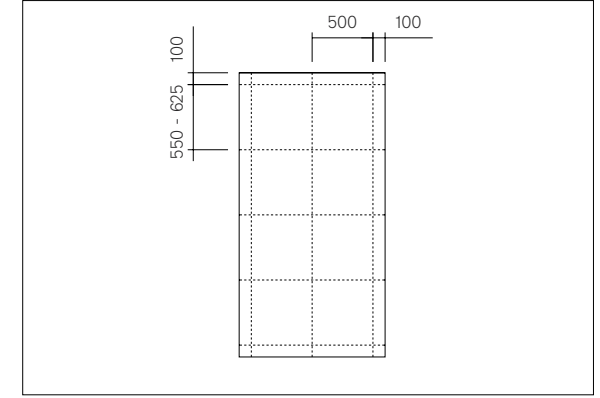

Measure and mark fixing points.

- Ideal clip spacing is 100 mm in from panel edges, and 550 - 625 mm apart.
- Approximately 15x fixing points are required per 2400 x 1200 mm panel.
- Adjust fixing points for studs as required.

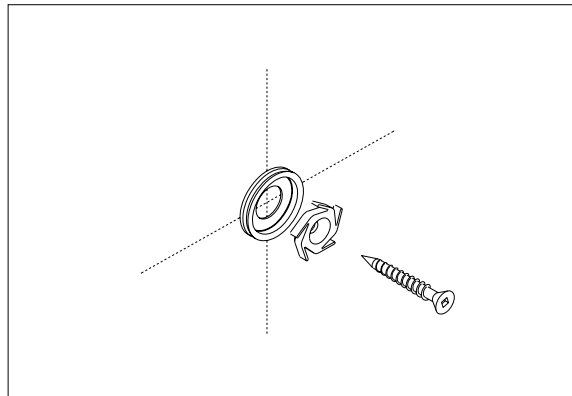

Fix SpinFix button and washer to substrate.

- It is the building contractor's responsibility to use appropriate wall fixings.
- 6 gauge screws recommended.

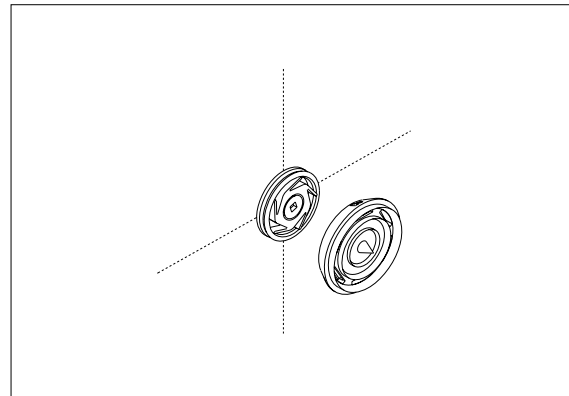

Click SpinFix clips to buttons.



## Install method

### SpinFix—prepping and fixing the panel

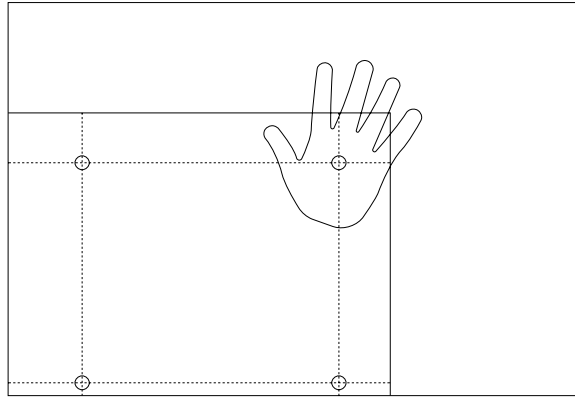

Press panel onto SpinFix clips to mark the fixing points.

- Position panel on your Hang-Right Brackets in the exact position the panel will be installed.
- Firmly press panel around each clip position to create impression in sheet. Note: do not hit the panel, as this can discolour the material.
- Once all SpinFix clips have been pressed, remove the panel and lay flat on a working surface. **At this point you should clearly see 15 small impressions in the back of the panel. These are your fixing points.**
- Remove SpinFix clips from buttons on the wall.

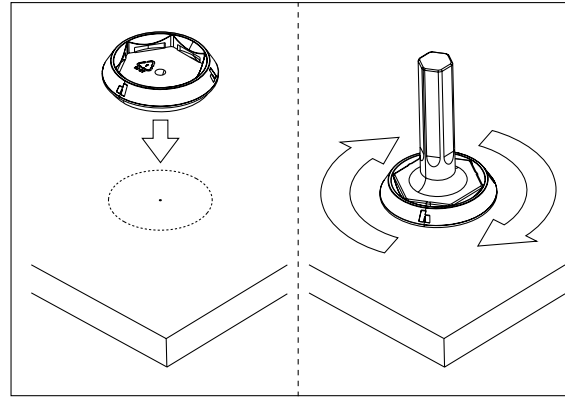

Connect SpinFix clips to panel.

- Attach Drill Tool to power-drill.
- Set spin speed and torque to high.
- Locate SpinFix clip point on panel impression.
- Push Drill Tool into SpinFix clip. Use the weight of the drill as pressure when fixing clips.
- Hold power drill straight and pull trigger. **Spin at max speed for approximately 3-5 seconds (until clip edge is flush with the panel surface).**
- Stop spinning, hold the clip with your fingers, and remove the Drill Tool from the clip.

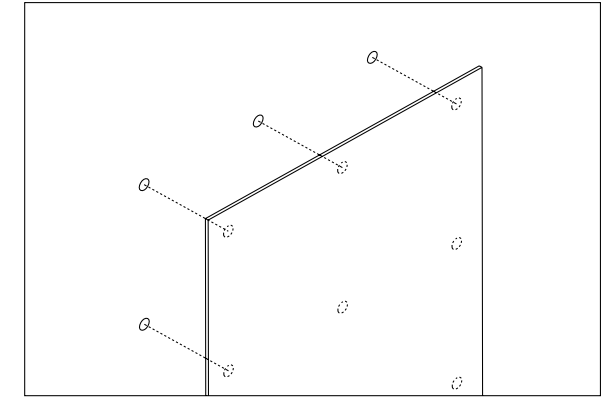

Fix panel to substrate.

- Once all clips are attached to the panel, transfer to the fixing wall.
- Press SpinFix clips to wall buttons, leaning your panel on the hang-right brackets to align.
- An audible click should register the SpinFix clips are fixed.
- Tip: start with the top SpinFix clips, this will help simplify finding and pressing the following clips.
- Remove Hang-Right Brackets from wall to use on the next panel. The two screws that held the Hang-Right Bracket can remain in the wall hidden by the installed panel.

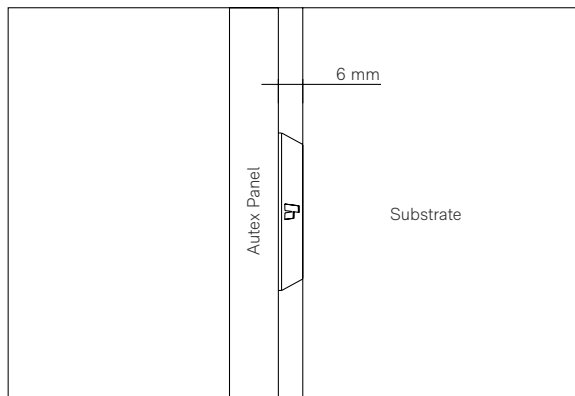

SpinFix clips create a 6 mm air gap for added acoustic performance.

For panels in high traffic areas, we recommend a 5-6 mm packer be installed between the panel and the substrate to support the panel edges.

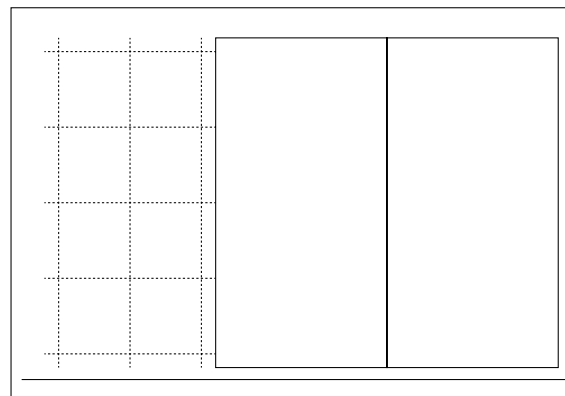

Repeat process for adjacent panels.

Note: a consisted kick trim is ideal for bottom-edge alignment during install and throughout product life.

Autex Acoustics Edging Solutions accessories can also be utilised for refined install execution.



## Acoustic performance

Selected Autex Acoustic products have been tested to determine the improvement in acoustic performance. SpinFix is shown to increase acoustic performance by 5-10%.

Frequency (Hz)	125	250	500	1000	2000	4000	NRC
12 mm Cube	0.05	0.10	0.30	0.65	0.90	0.95	0.45
12 mm Cube (with 6 mm air gap)	0.05	0.10	0.35	0.75	0.95	0.95	0.55
24 mm Cube	0.05	0.20	0.60	0.90	1.00	1.00	0.70
24 mm Cube (with 6 mm air gap)	0.10	0.30	0.70	0.95	1.00	1.00	0.75
25 mm Quietspace Panel	0.15	0.45	0.85	1.00	1.00	0.95	0.85
25 mm Quietspace Panel (with 6 mm air gap)	0.20	0.55	0.90	1.00	1.00	0.95	0.90

Note: If SpinFix is being used in an application where panel removal is required to access services, we recommend using Cube panels, as they offer greater durability.



In everything we do

### ● New Zealand

702-718 Rosebank Road,  
Private Bag 19988  
Avondale 1746, Auckland  
T 0800 428 839  
T +64 9 828 9179  
[autexacoustics.co.nz](http://autexacoustics.co.nz)

### ● Australia

285 Swan Street,  
Richmond, VIC 3121  
T 1800 678 160  
T +61 3 9450 6700  
[autexacoustics.com.au](http://autexacoustics.com.au)

### ● United Kingdom

Unit J4, Lowfields Way,  
Lowfields Business Park,  
Elland, West Yorkshire  
HX5 9DA  
T +44 0 142 241 8899  
[autexacoustics.co.uk](http://autexacoustics.co.uk)

### ● United States

1630 Dan Kipper Drive,  
Riverside, CA 92507  
T +1 424 203 1813  
[autexacoustics.com](http://autexacoustics.com)

Autex is an ISO certified organisation encompassing Quality (ISO 9001), Environmental (ISO 14001), and Health and Safety (ISO 45001). Brand names and logos are registered or unregistered trademarks owned or used under license by Autex Industries Limited or other members of the Autex Group. © Copyright 2024 Autex Industries Ltd. All rights reserved. It is the user's responsibility to determine if the product and information presented in this document is suitable for the intended application by engaging a suitably qualified consultant. The information contained in this document is correct to the best of our knowledge at the date of its publication. To verify that this document is the most current publication please check our website or contact your Autex Acoustics account manager.