

Specification Guide

Groove™ is a semi-rigid, lightweight router-cut panel with precise angular designs that bend and distort light to create depth, nuance, and texture.

With 12 unique designs, Groove enables everything from subtle surface detailing to bold eye catching patterns. It can transform any space by introducing dynamic light play and dimensionality.



In everything we do



Groove™



Path to Specification

1. Space

What are the dimensions of the space you are designing?

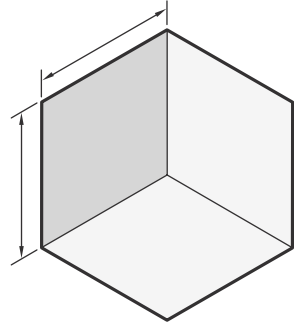

2. Size

What panel dimensions are available?

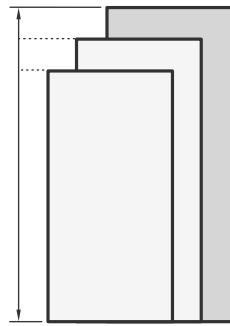

3. Style

What styles are available?

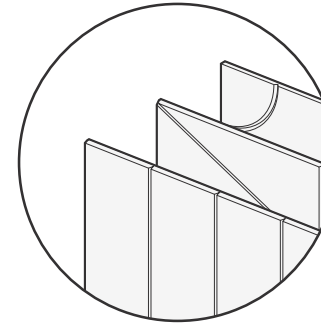

4. Layout

What orientations are possible?

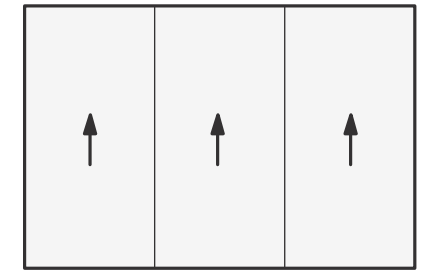

[Page 3](#)

[Page 4](#)

[Page 5-16](#)

5. Configuration

What details are editable?

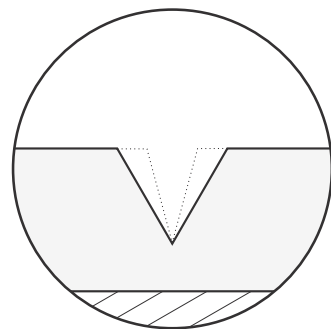

6. Detail Considerations

What install details should I consider?

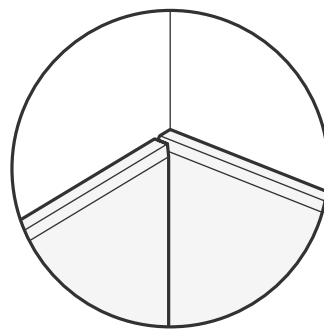

7. Colours

What colours are available?

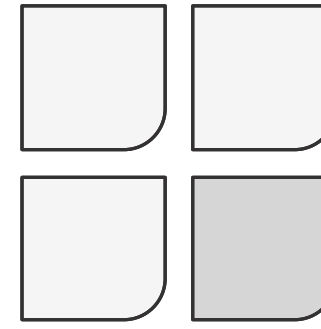

8. Technical Information

What are the technical specifications?

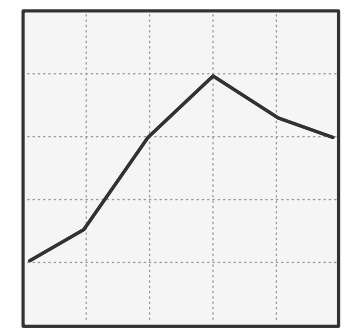

[Page 17-19](#)

[Page 20](#)

[Page 21](#)

[Page 24](#)



Quick Reference

Panel Dimensions

- Width** 1200mm
- Height** 2400mm, 2700mm (standard)
<3600mm (MOQs apply)
- Thickness** 12mm, 24mm

If pattern matching different sized panels, e.g. 2400mm and 2700mm, please be sure to check the [Standard Panel Sizes](#) pages in this guide.

Connection

- Adhesive** Panels can be installed with appropriate adhesive (supplied by contractor)
- Peel-and-Stick** Adhesive back supplied by Autex Acoustics®
- SpinFix™** See SpinFix™ install guide
See Product Installation Guide for further details

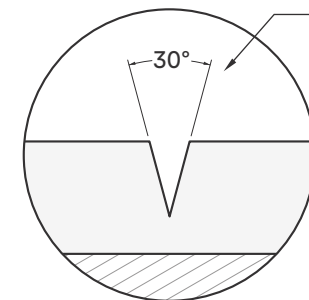
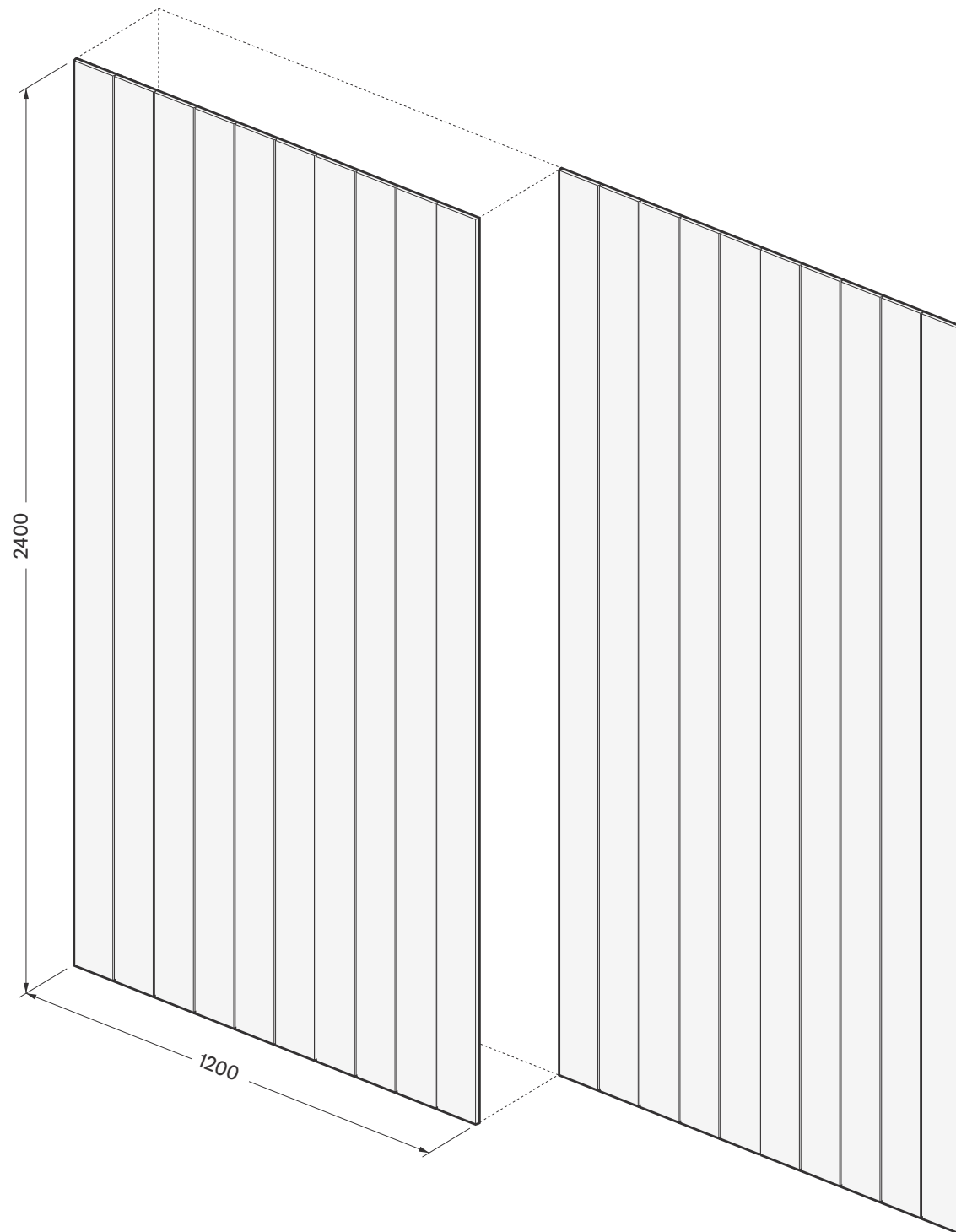

Unless otherwise specified, all Grooves will be 30 degrees, at 8mm deep

Standard Groove Angle

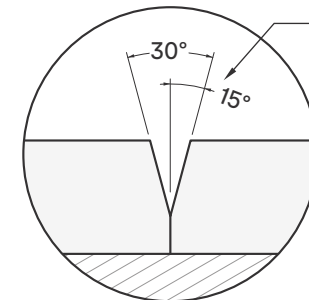

Panel side-edges are bevelled with half of the specified groove angle for seamless panel joins

Panel Join



Styles Overview

Stripe V1

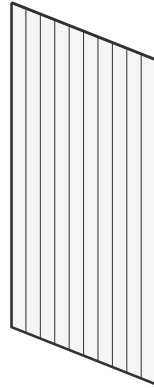

Oblique V2

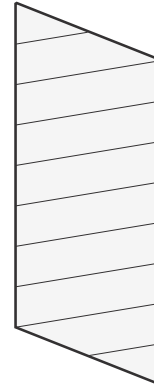

Mesh V3

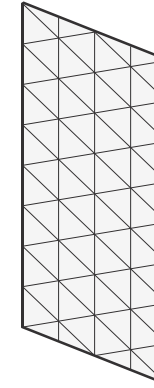

Gable V4

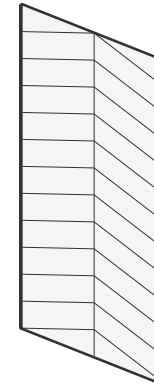

Radial V5

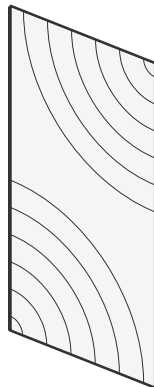

Bloc V6

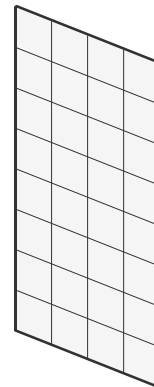

Bamboo V7

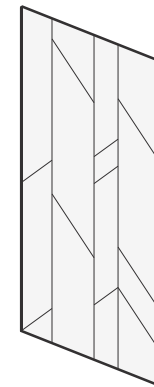

Facade V8

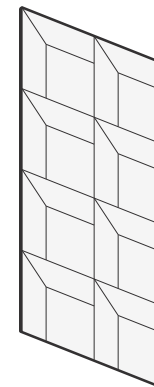

Whisp V9

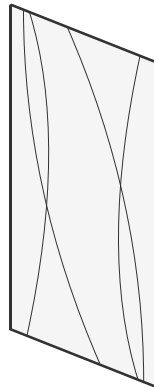

Arc V10

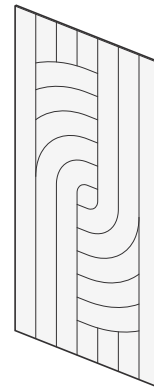

Refract V11

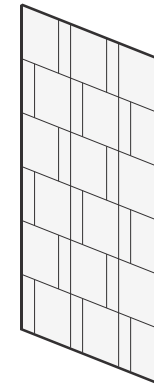

Nova V12

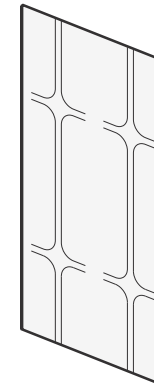



Stripe V1

- Stripe style is equal divisions of vertical grooves across a panel
- The dimensions listed below are standard options, but can be changed if needed
- 2700mm variations available, please refer to [pages 17-18](#) in this guide
- Unless specified otherwise, orders will be assumed to be all Panel A

Contact your Autex Acoustics account manager for further options.

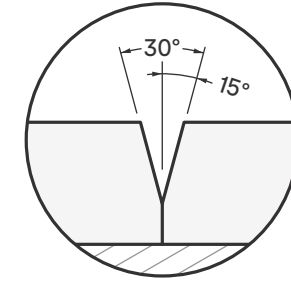

Panel side-edges are bevelled with half of the specified groove angle for seamless panel joins

Panel A - Standard Centres

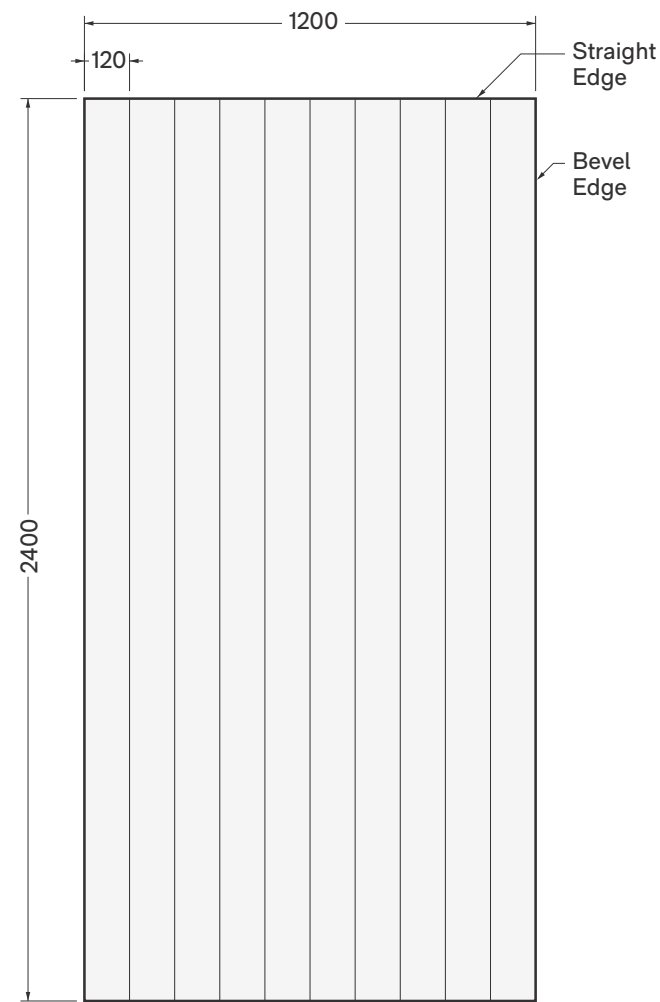

Panel B - Half Centres

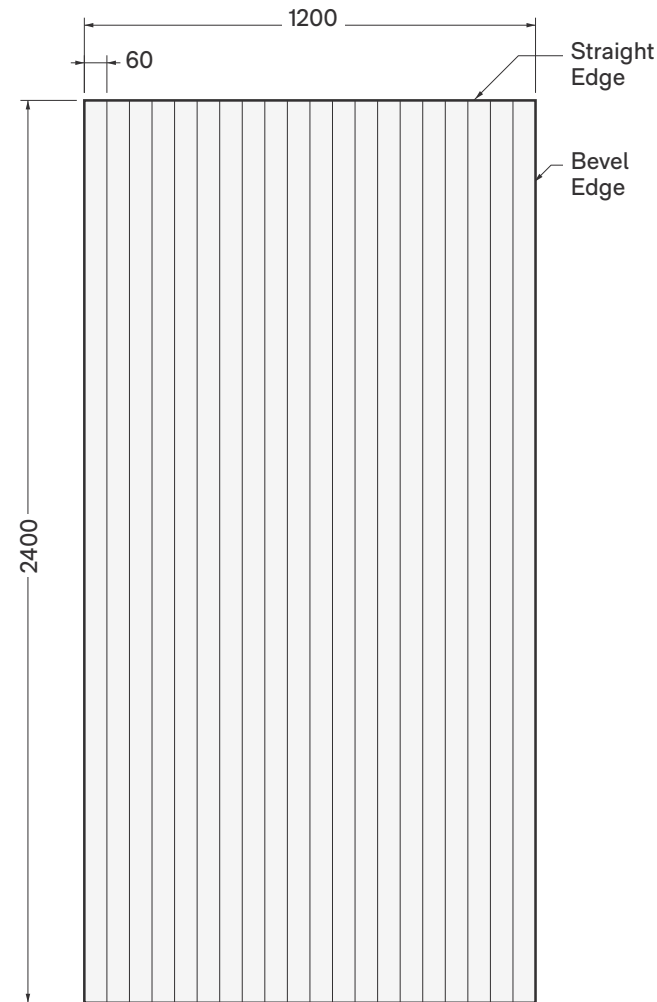

Panel C - Quarter Centres

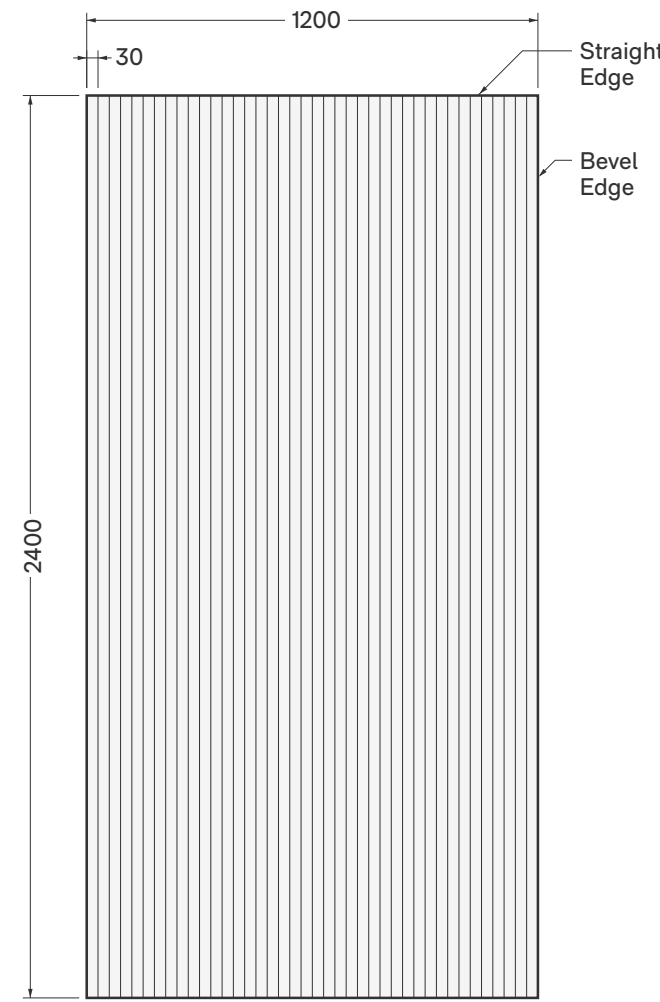

Layout Option

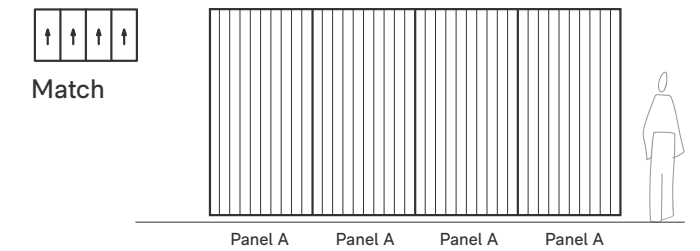



Oblique V2

- Oblique style is equal divisions of angle grooves across a panel
 - The dimensions listed below are standard options, but can be changed if needed
 - 2700mm variations available, please refer to [pages 17-18](#) in this guide
 - Unless specified otherwise, orders will be assumed to be all Panel A
- Contact your Autex Acoustics account manager for further options.

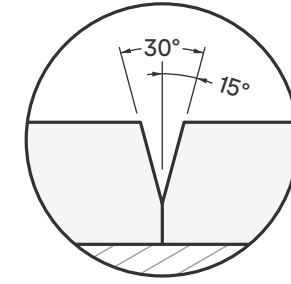

Panel side-edges are bevelled with half of the specified groove angle for seamless panel joins

Panel A - Standard

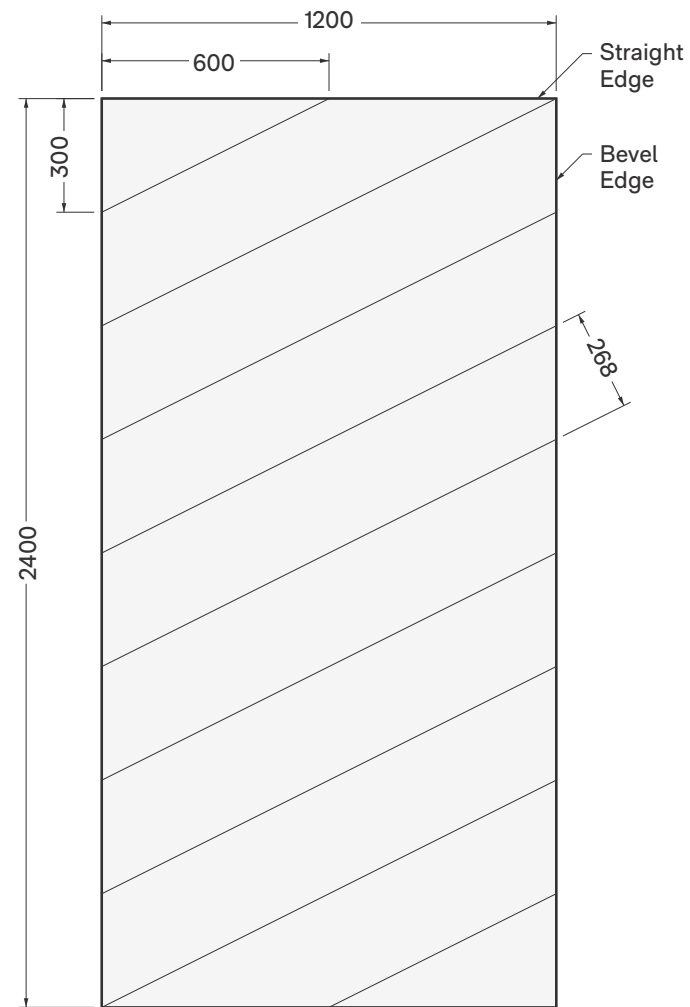

Panel B

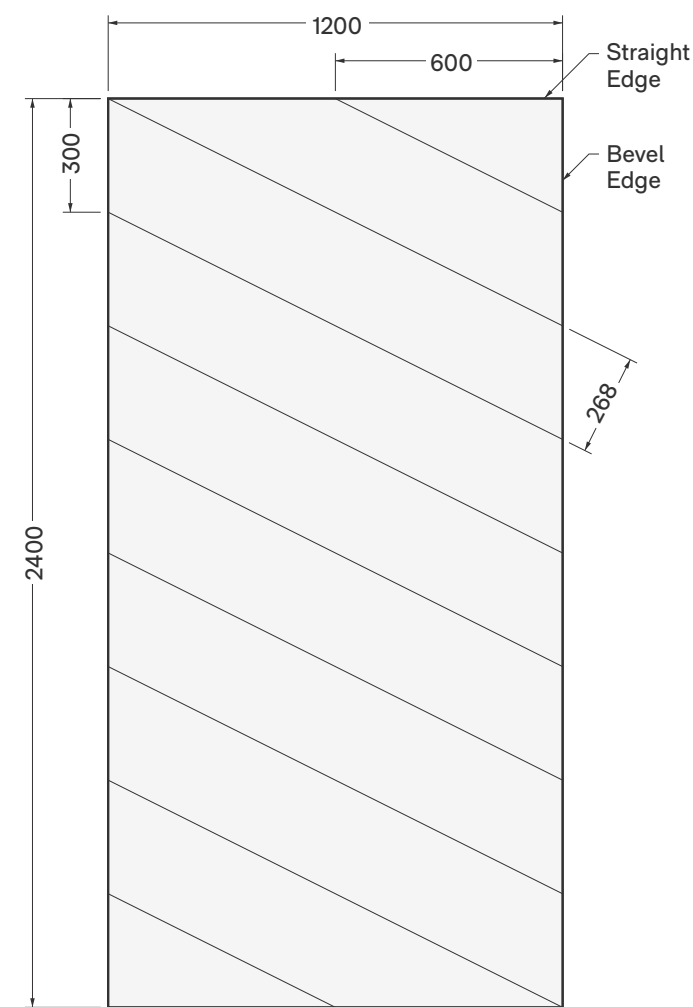

Layout Options

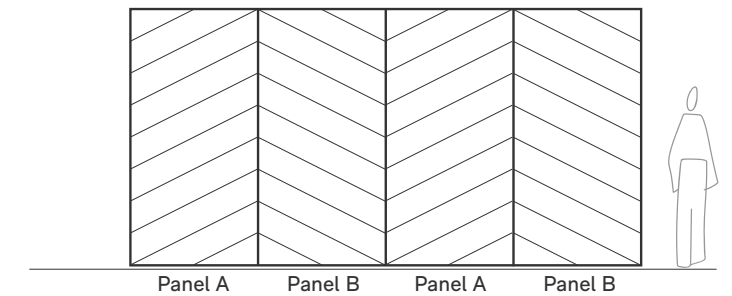
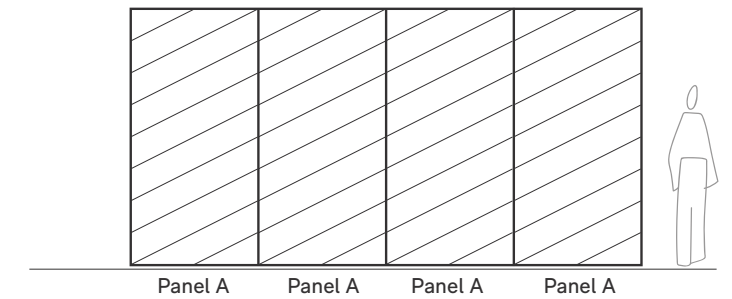
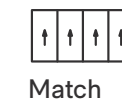



Mesh V3

- Mesh style is equal divisions of intersecting angled and vertical grooves across a panel
- The dimensions listed below are standard options, but can be changed if needed
- 2700mm variations available, please refer to [pages 17-18](#) in this guide

Contact your Autex Acoustics account manager for further options.

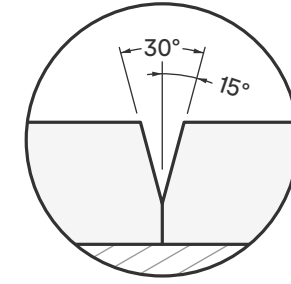

Panel side-edges are bevelled with half of the specified groove angle for seamless panel joins

Panel A

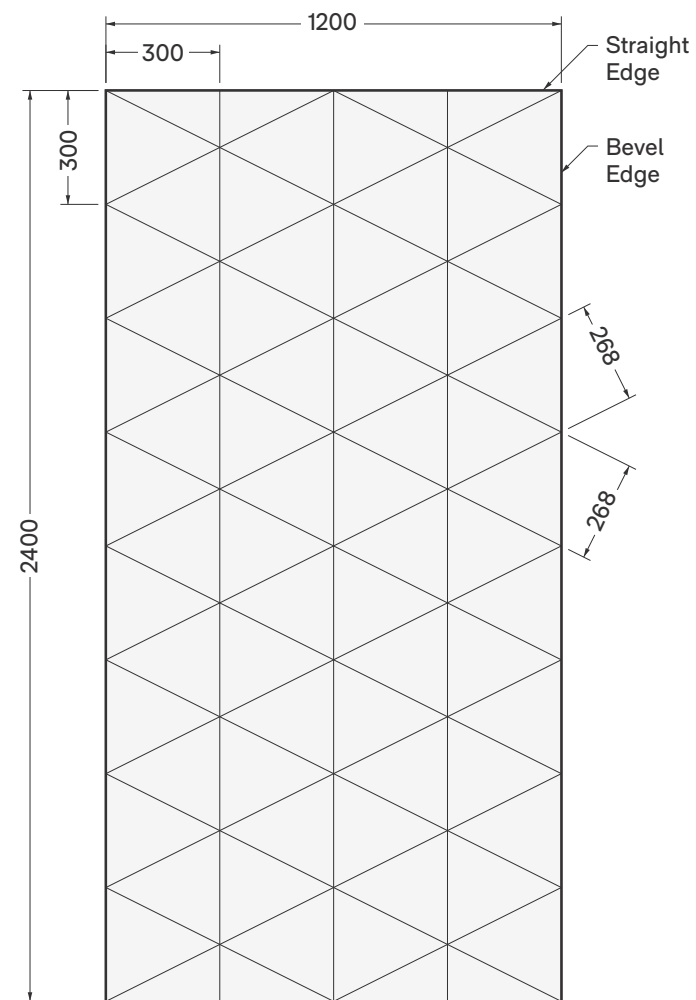

Layout Option

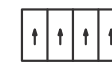

Match

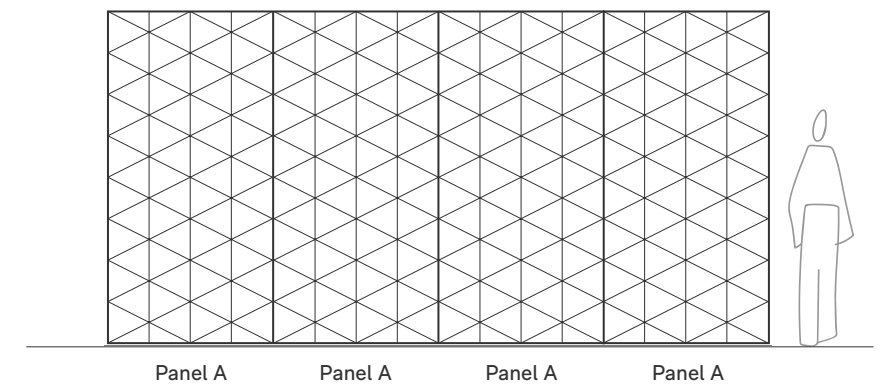



Gable V4

- Gable style is equal divisions of angled grooves, mirrored along the centre of a panel
- The dimensions listed below are standard options, but can be changed if needed
- 2700mm variations available, please refer to [pages 17-18](#) in this guide

Contact your Autex Acoustics account manager for further options.

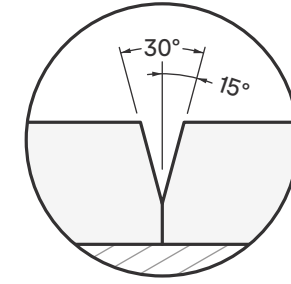

Panel side-edges are bevelled with half of the specified groove angle for seamless panel joins

Panel A

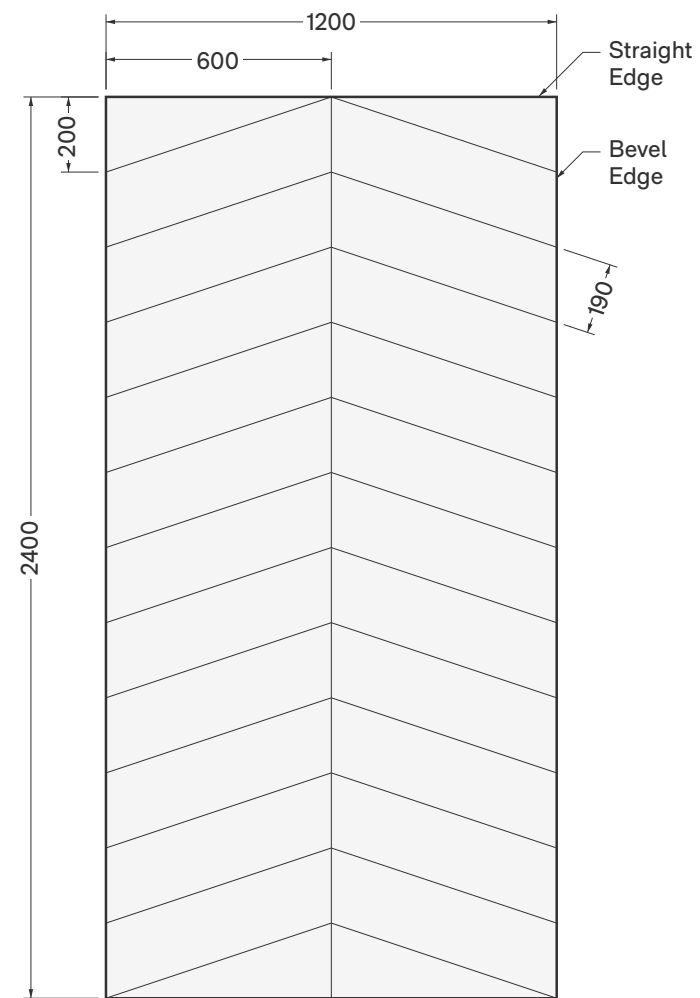

Layout Options

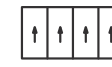

Match

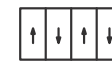

Flip

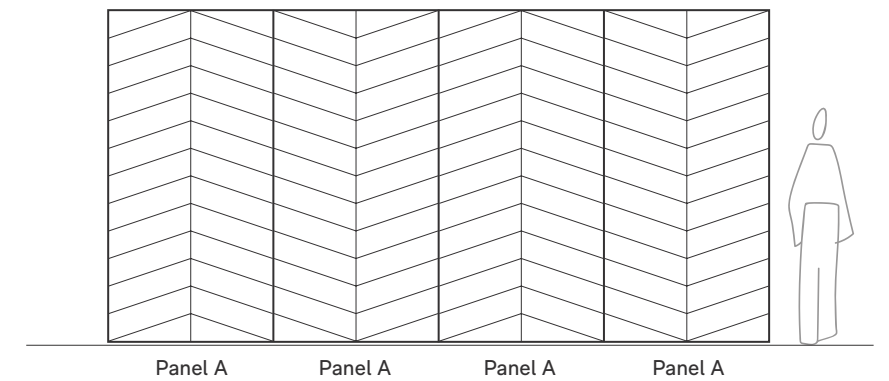
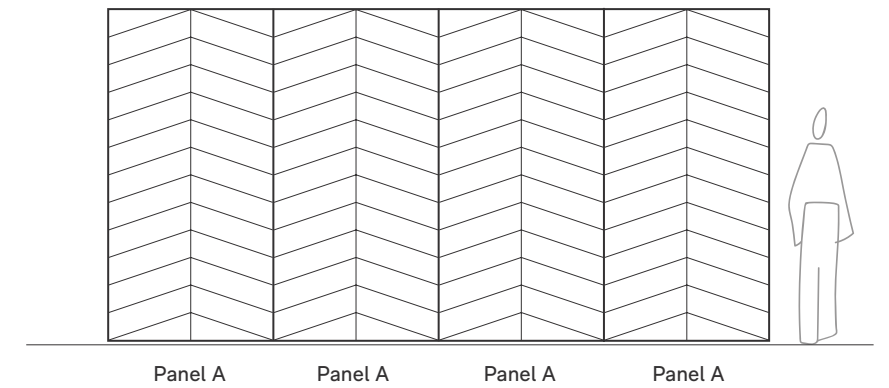



Radial V5

- Radial style is equal divisions of concentric grooves on opposite corners of a panel
 - The dimensions listed below are standard options, but can be changed if needed
 - 2700mm variations available, please refer to [pages 17-18](#) in this guide
 - Unless specified otherwise, orders will be assumed to be all Panel A
- Contact your Autex Acoustics account manager for further options.

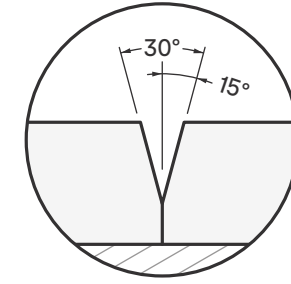

Panel side-edges are bevelled with half of the specified groove angle for seamless panel joins

Panel A - Standard

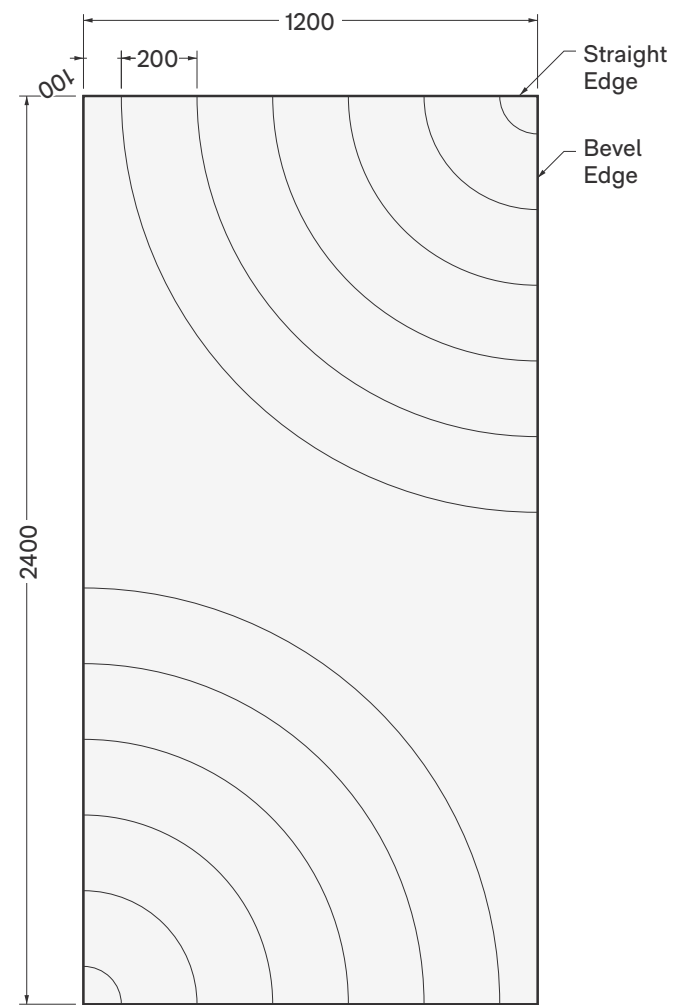

Panel B

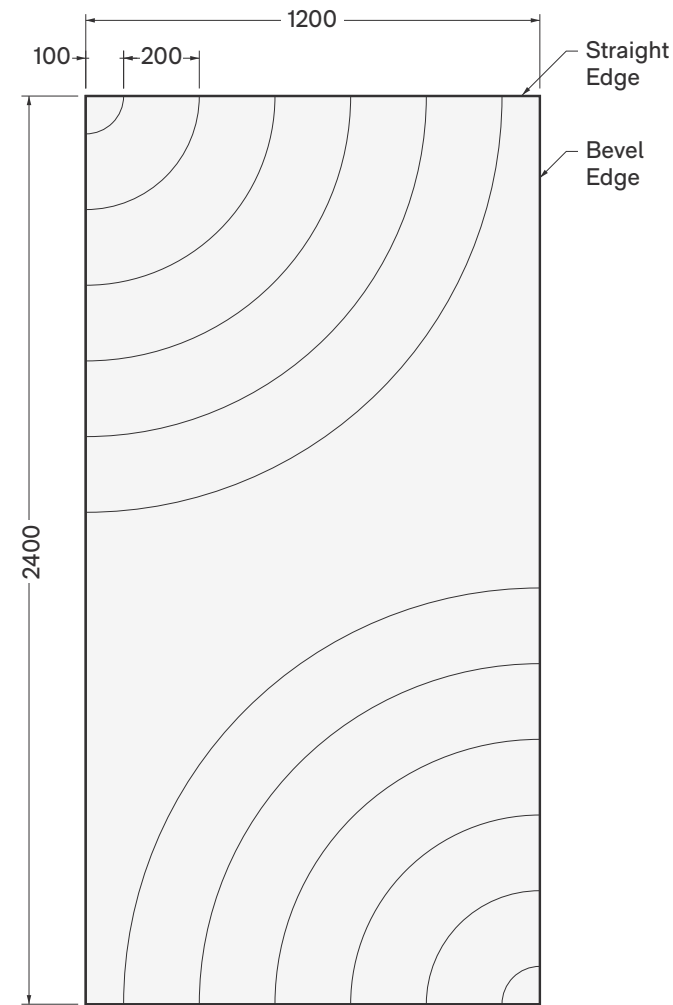

Layout Options

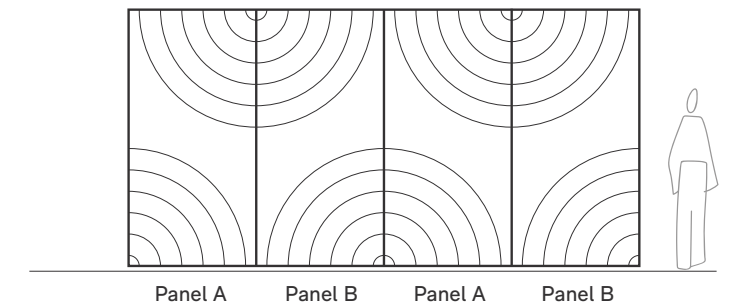
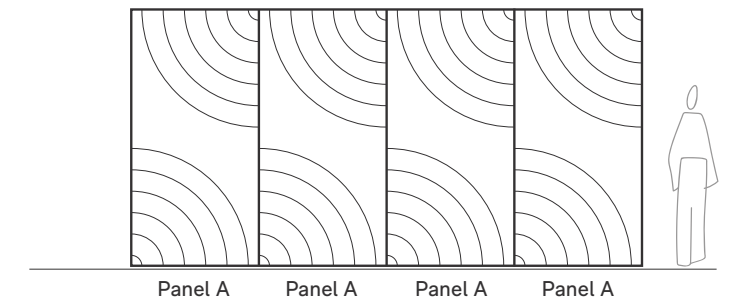
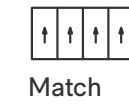



Bloc V6

- Bloc style is equally-spaced vertical and horizontal grooves across a panel
- The dimensions listed below are standard options, but can be changed if needed
- 2700mm variations available, please refer to [pages 17-18](#) in this guide

Contact your Autex Acoustics account manager for further options.

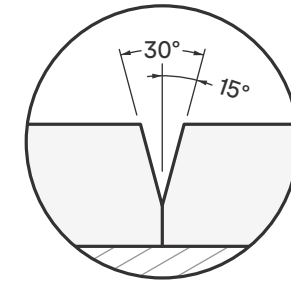

Panel side-edges are bevelled with half of the specified groove angle for seamless panel joins

Panel A

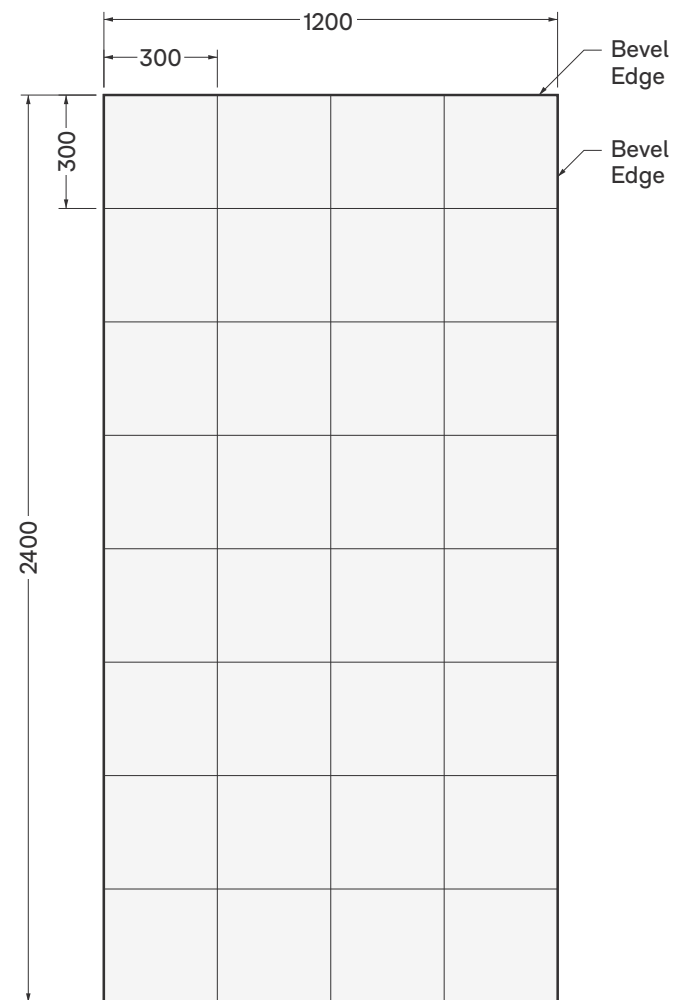

Layout Option

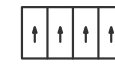

Match

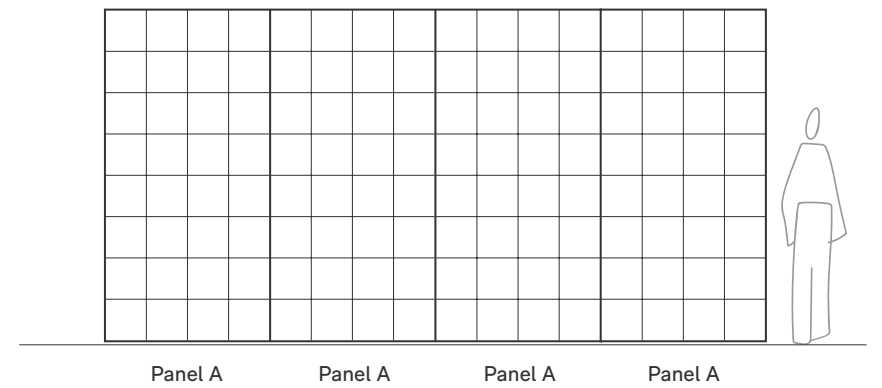



Bamboo V7

- Bamboo style is irregular vertical spacings with angled grooves between
 - The dimensions listed below are standard options, but can be changed if needed
 - 2700mm variations available, please refer to [pages 17-18](#) in this guide
 - Unless specified otherwise, orders will be assumed to be all Panel A
- Contact your Autex Acoustics account manager for further options.

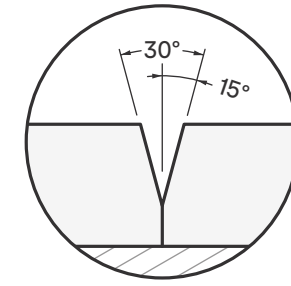

Panel side-edges are bevelled with half of the specified groove angle for seamless panel joins

Panel A - Standard

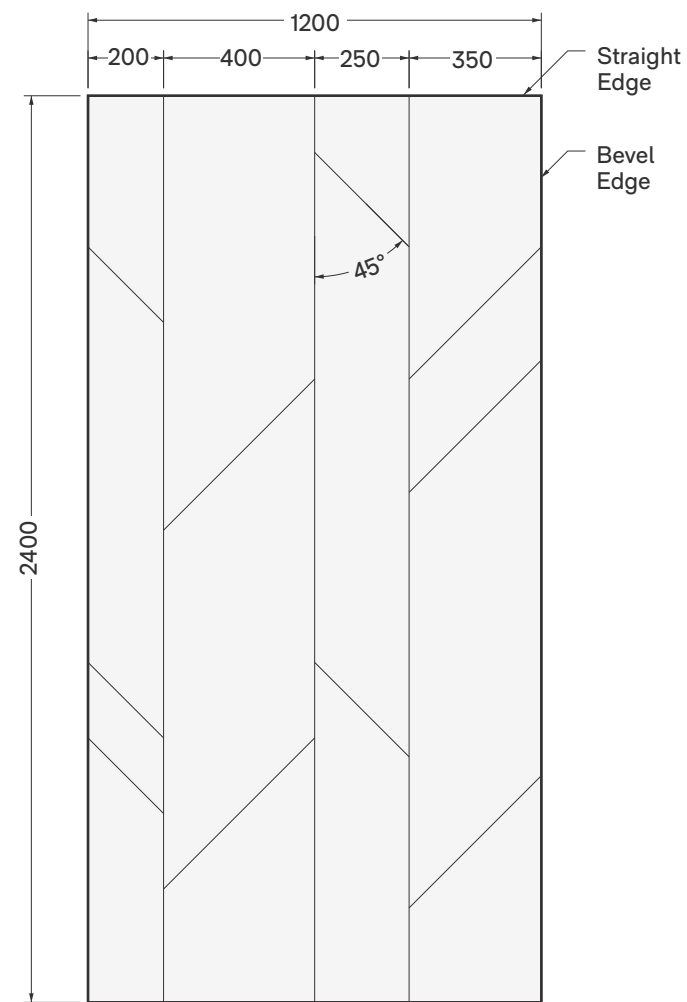

Panel B

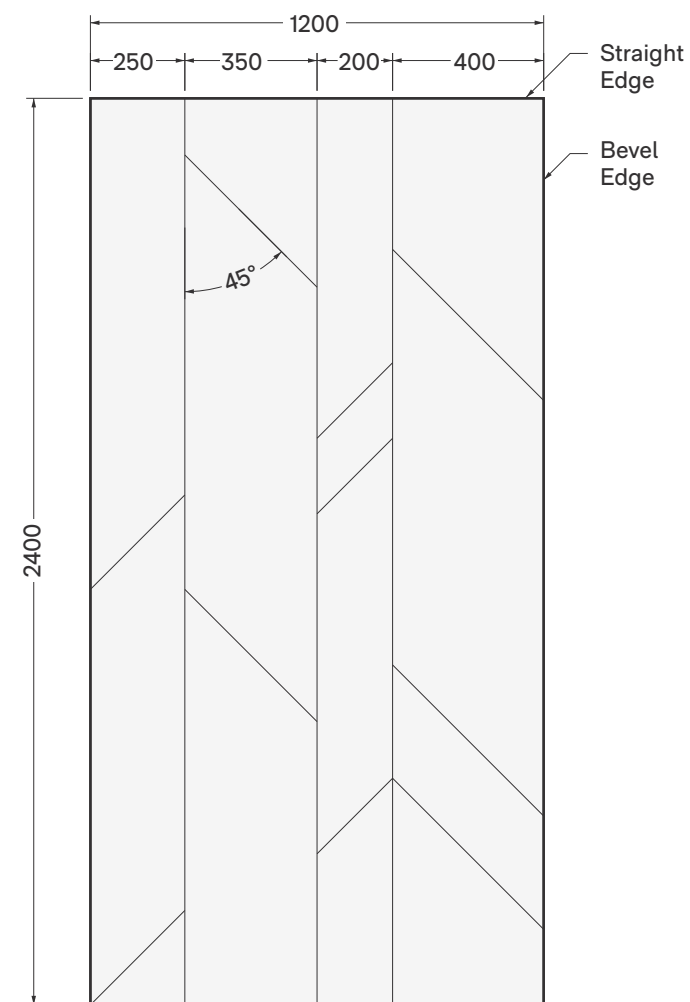

Layout Options

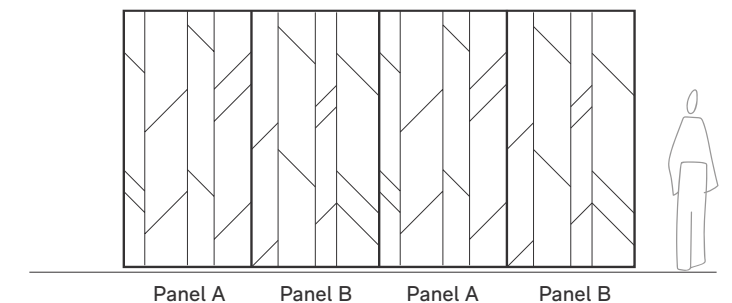
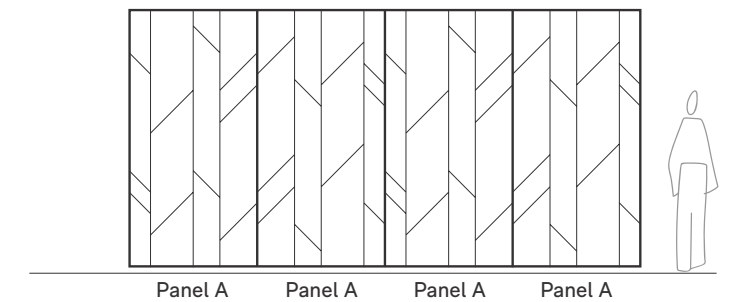
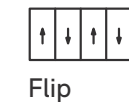
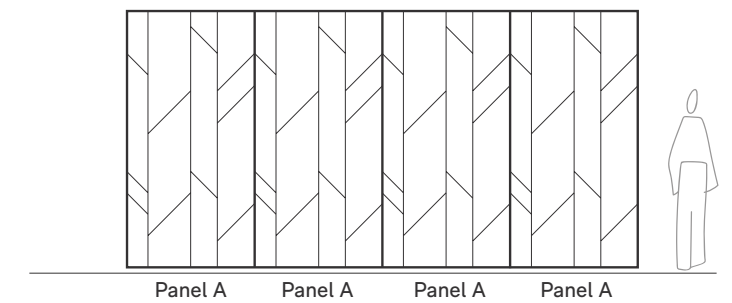
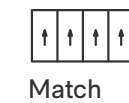

A small amount of overcut is normal with this design. It is generally not visible unless overtly highlighted. Please speak to your Autex Acoustics account manager to see a sample.



Facade V8

- Facade is a division of equal squares with a consistent notch detail in each
- The dimensions listed below are standard options, but can be changed if needed
- 2700mm variations available, please refer to [pages 17-18](#) in this guide

Contact your Autex Acoustics account manager for further options.

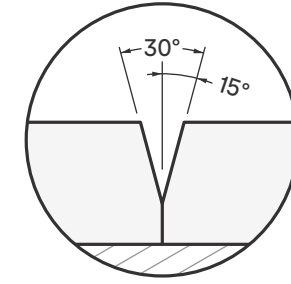

Panel side-edges are bevelled with half of the specified groove angle for seamless panel joins

Panel A

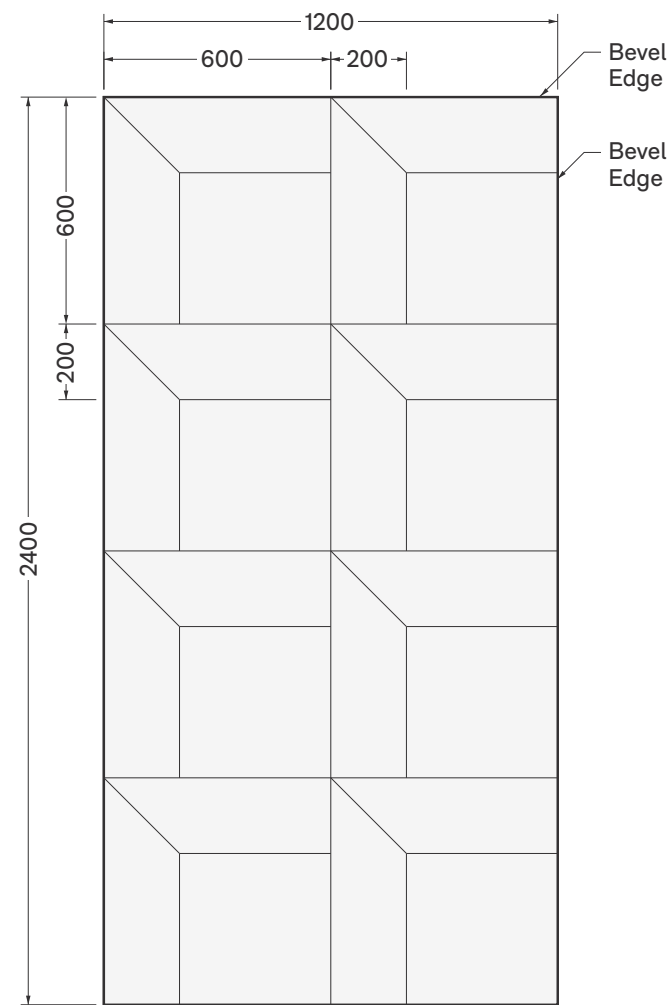

Layout Option

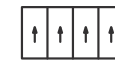

Match

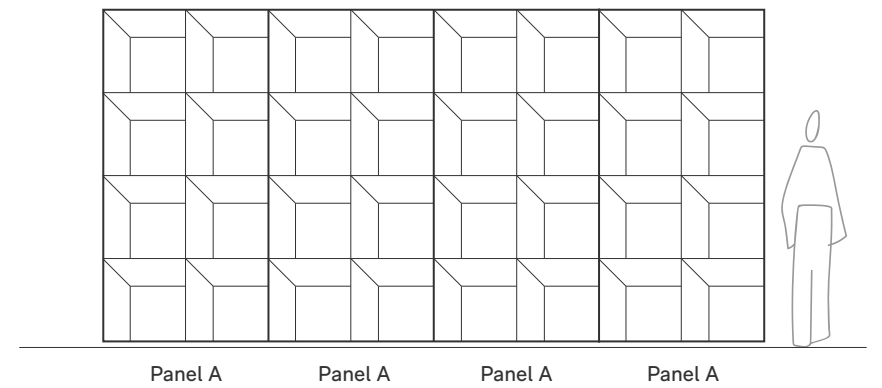



Whisp V9

- Whisp is a pair of organic sweeping curves which are rotationally symmetrical
- The dimensions listed below are standard options, but can be changed if needed
- 2700mm variations available, please refer to [pages 17-18](#) in this guide

Contact your Autex Acoustics account manager for further options.

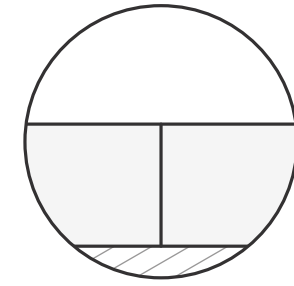

Panel side-edges are straight-cut to ensure clean, consistent joins

Panel A

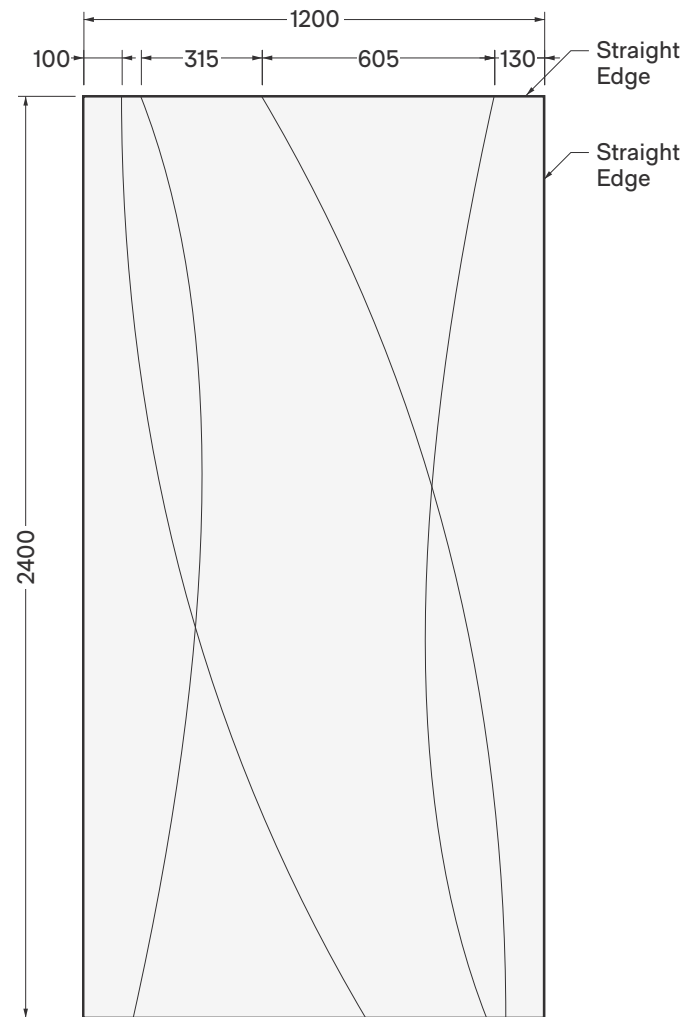

Layout Option

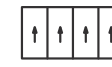

Match

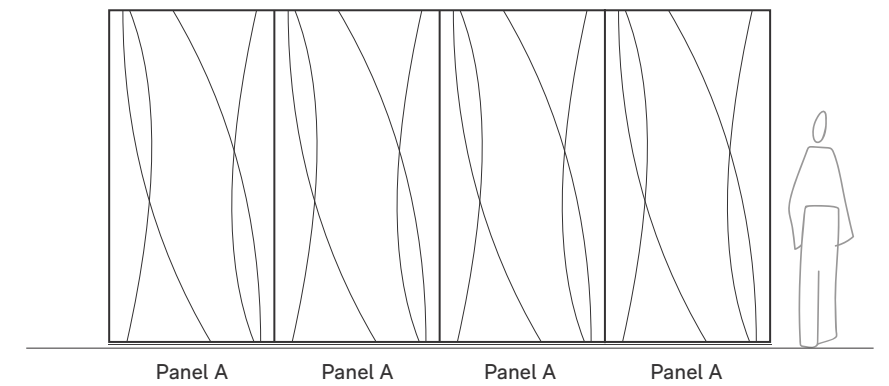



Arc V10

- Arc is a group of sweeping tangent curves, which allow for tessellation on all panel edges
- The dimensions listed below are standard options, but can be changed if needed
- 2700mm variations available, please refer to [pages 17-18](#) in this guide
- Unless specified otherwise, orders will be assumed to be all Panel A

Contact your Autex Acoustics account manager for further options.

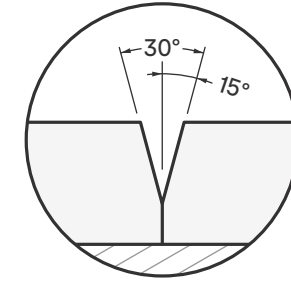

Panel side-edges are bevelled with half of the specified groove angle for seamless panel joins

Panel A - Standard

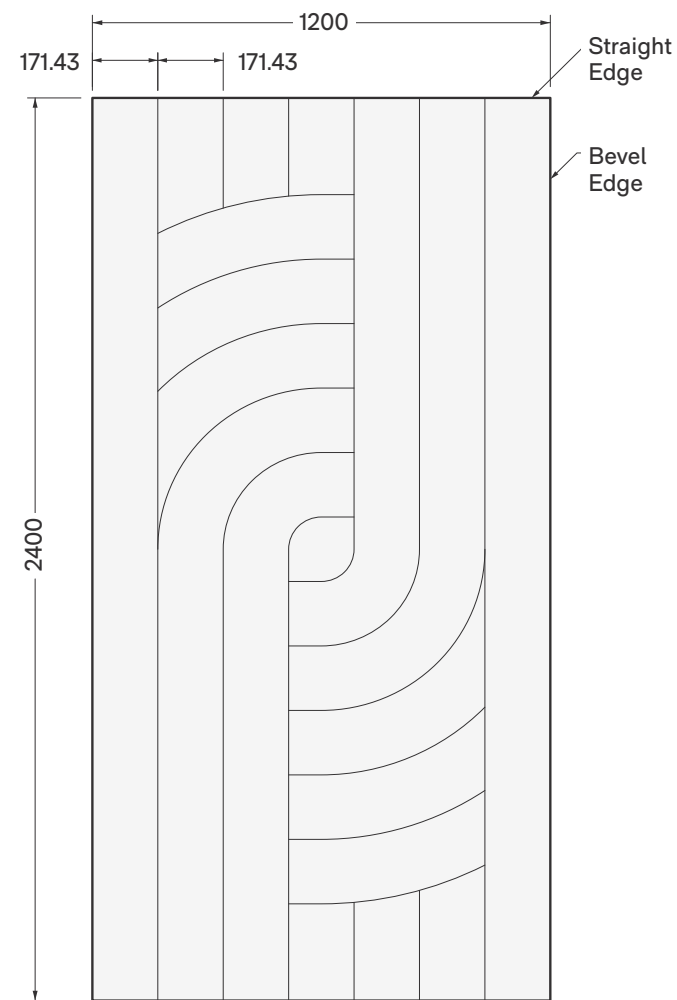

Layout Options

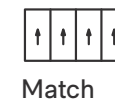

Match

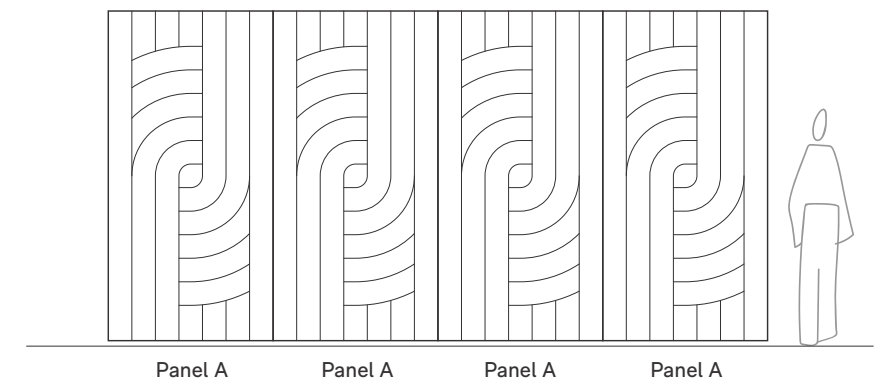



Refract V11

- Refract is a division of equally-spaced vertical and horizontal grooves with an alternating pattern throughout
- The dimensions listed below are standard options, but can be changed if needed
- 2700mm variations available, please refer to [pages 17-18](#) in this guide

Contact your Autex Acoustics account manager for further options.

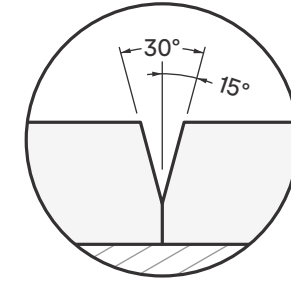

Panel side-edges are bevelled with half of the specified groove angle for seamless panel joins

Panel A

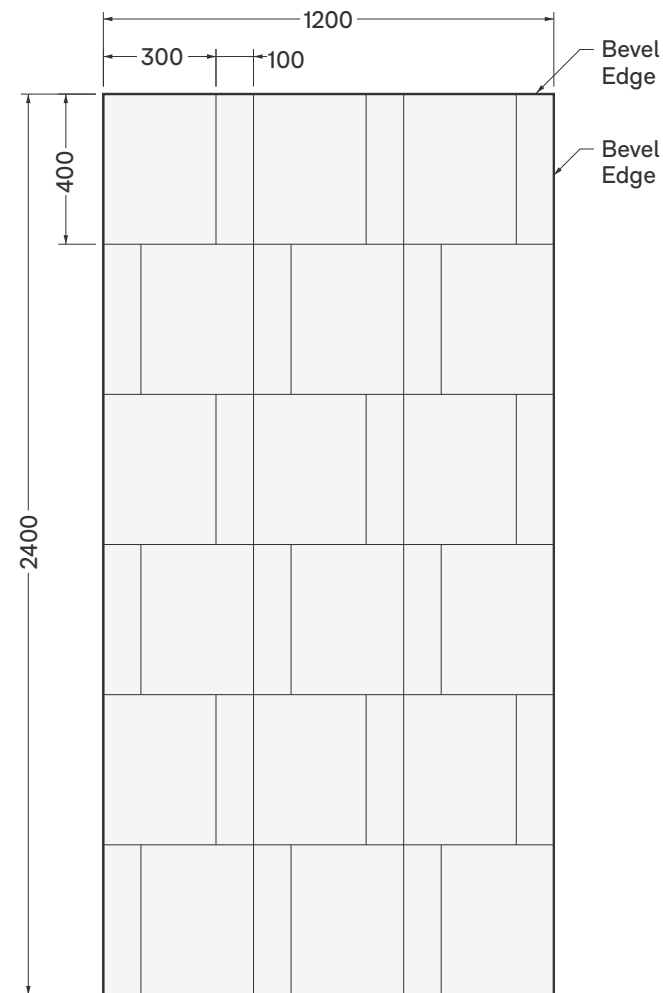

Layout Option



Match

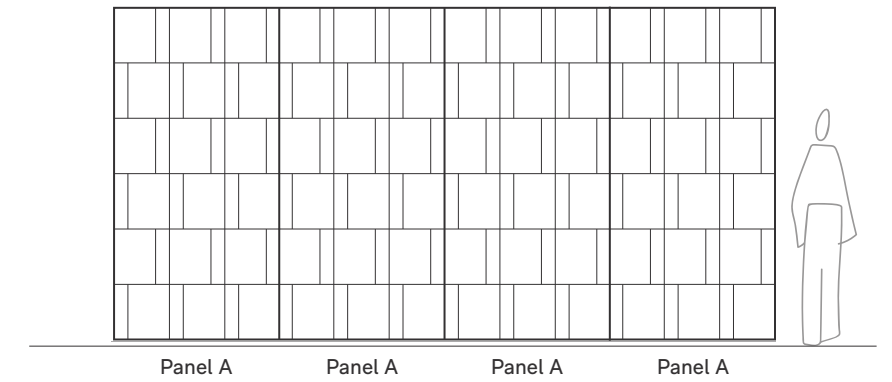



Nova V12

- Nova is an array of truncated grooves, which collectively make a gridded pattern across panels.
- The dimensions listed below are standard options, but can be changed if needed
- 2700mm variations available, please refer to [pages 17-18](#) in this guide

Contact your Autex Acoustics account manager for further options.

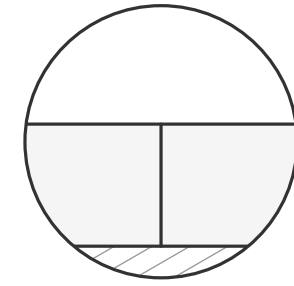

Panel side-edges are straight-cut to ensure clean, consistent joins

Panel A

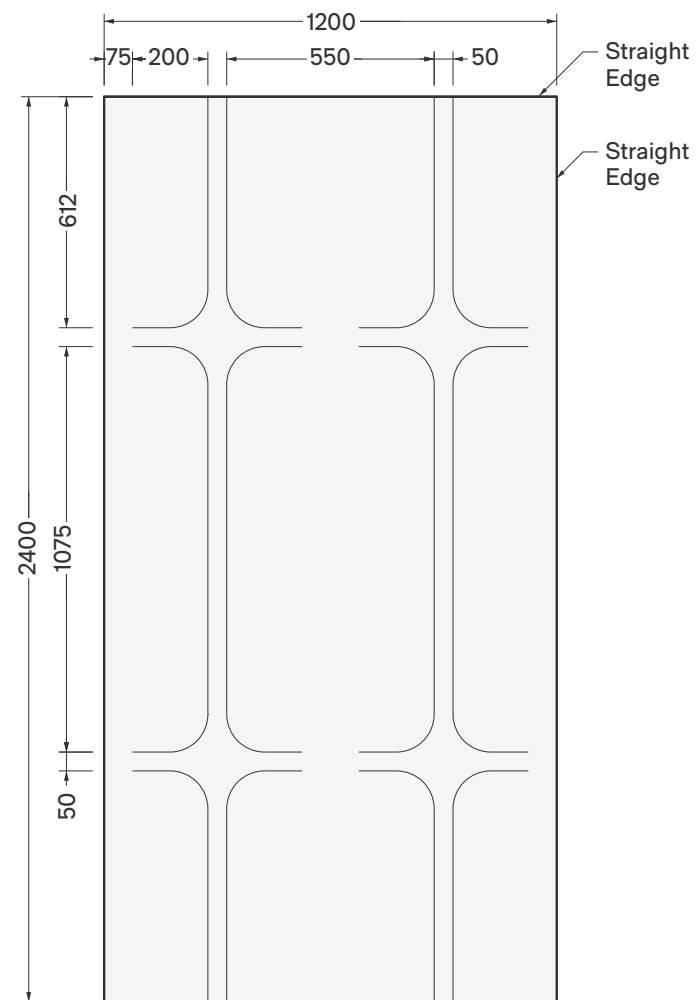

Layout Option

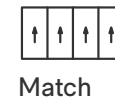

Match

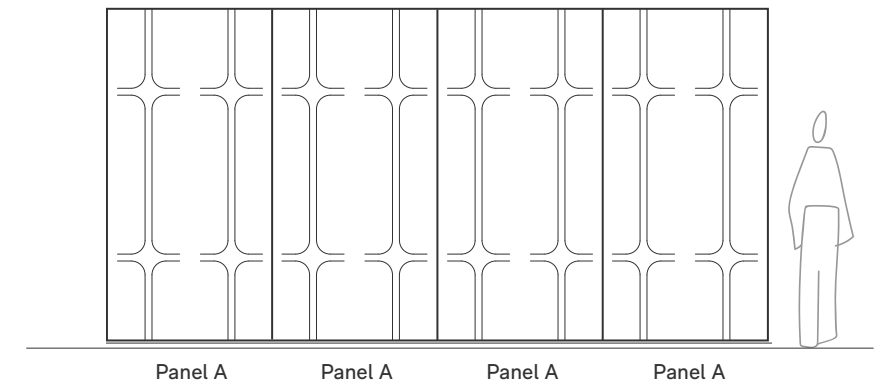



Standard Panel Sizes - Pattern Variation

Stripe V1

Stripe is equal vertical divisions of the panel.
The pattern can be matched across panels of any length.

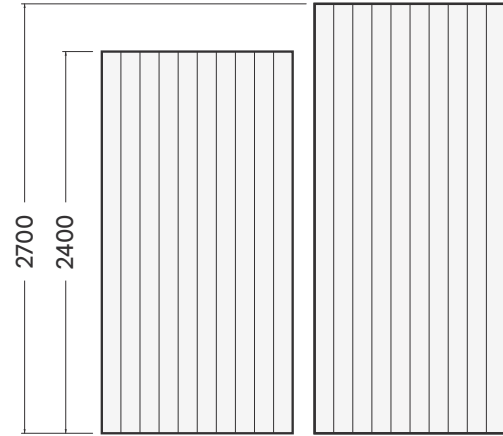

Oblique V2

Oblique is based off a 600mm x 300mm grid.
The pattern matches when using standard 2400mm and 2700mm panels.

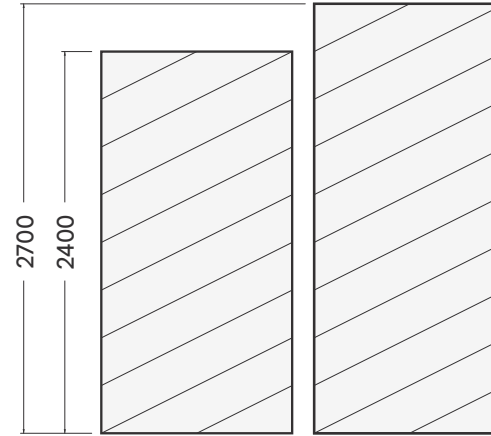

Mesh V3

Mesh is based off a 300mm x 300mm grid.
The pattern matches when using standard 2400mm and 2700mm panels.

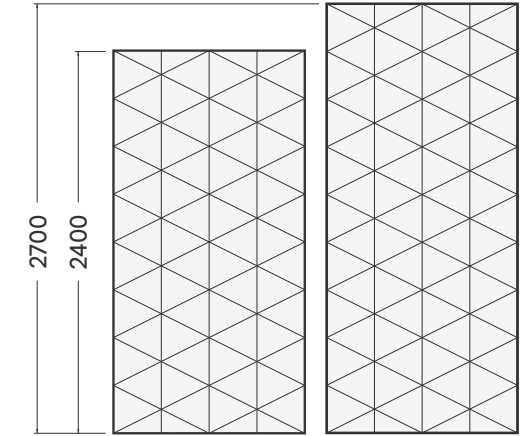

Gable V4

Gable is equal divisions of the panel height and pattern repeat shifts with the change in length. The pattern does not match when using standard 2400mm and 2700mm panels.

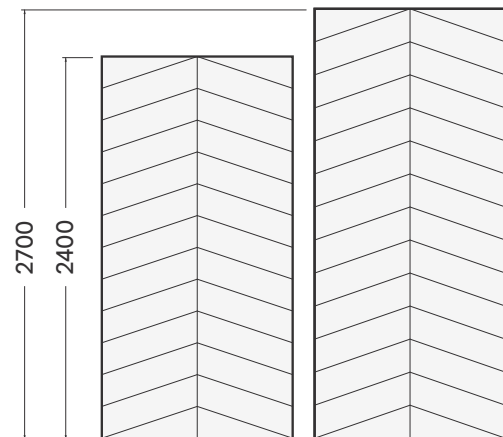

Radial V5

Radial is corner-justified and shifts with the change in length. The pattern does not match when using standard 2400mm and 2700mm panels.

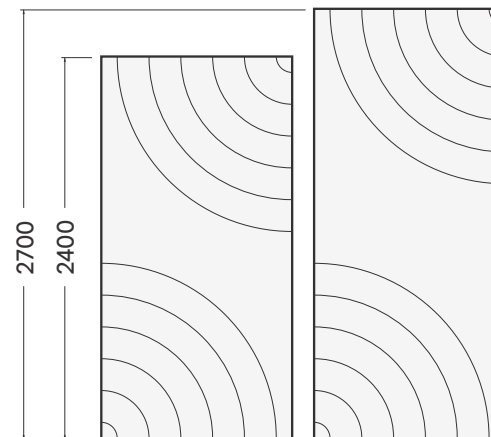

Bloc V6

Bloc has equal 300mm x 300mm divisions. The pattern matches when using standard 2400mm and 2700mm panels.

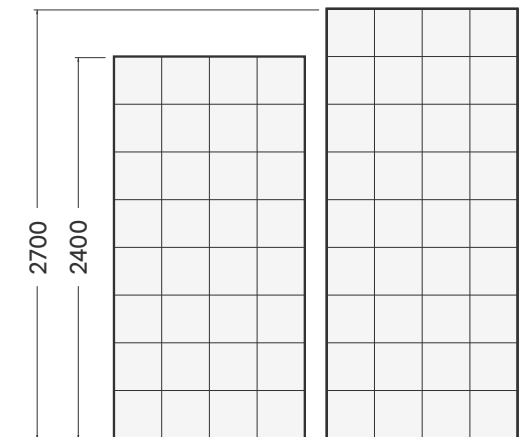



Standard Panel Sizes - Pattern Variation

Bamboo V7

Bamboo is centred and vertical grooves extend to the panel edge with the change in panel length. The pattern does not match when using standard 2400mm and 2700mm panels.

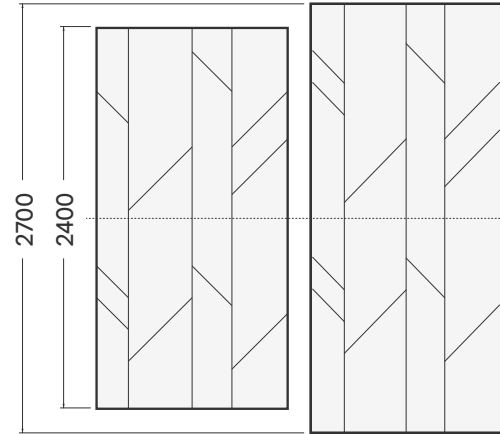

Facade V8

Facade stretches with the change in length. The pattern does not match when using standard 2400mm and 2700mm panels.

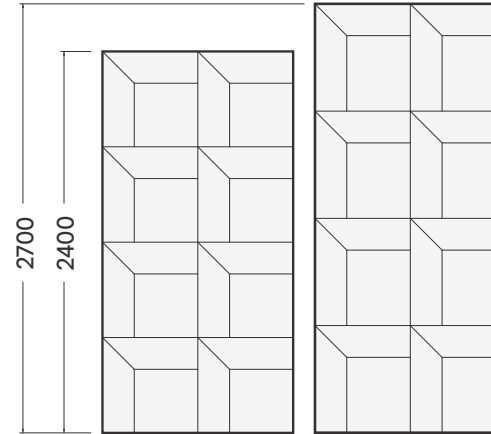

Whisp V9

Whisp stretches with the change in panel length. The pattern does not match when using standard 2400mm and 2700mm panels.

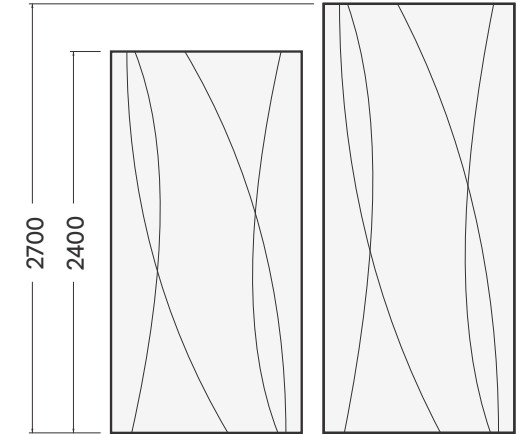

Arc V10

Arc is centred and vertical grooves extend to the panel edge with the change in panel length. The pattern does not match when using standard 2400mm and 2700mm panels.

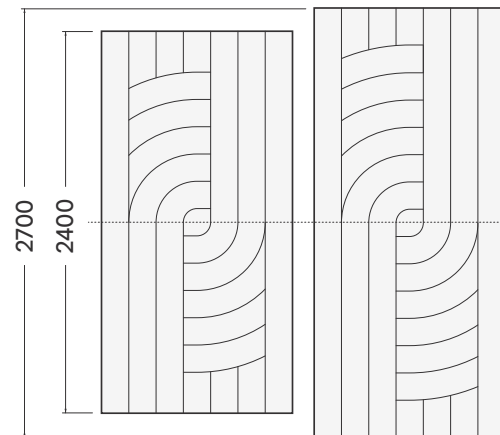

Refract V11

Refract stretches with the change in panel length. The pattern does not match when using standard 2400mm and 2700mm panels.

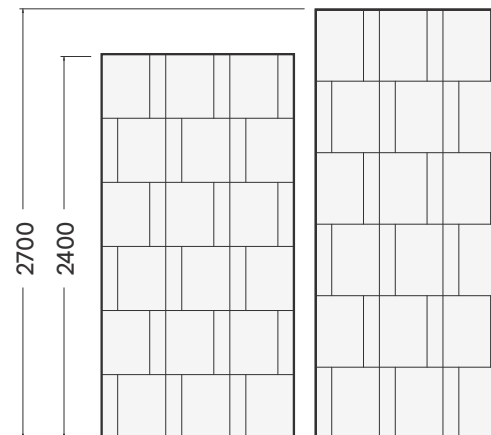

Nova V12

Nova stretches with the change in panel length. The pattern does not match when using standard 2400mm and 2700mm panels.

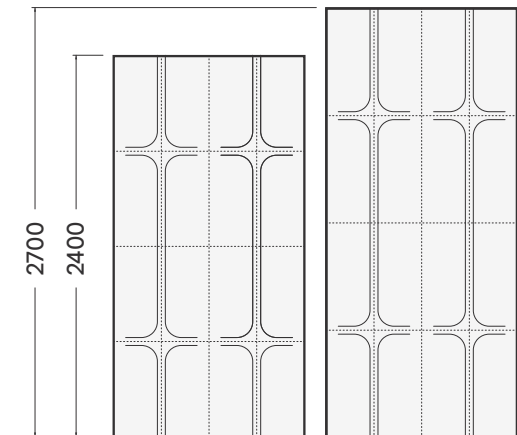



Customisation

Groove™ Angle Options

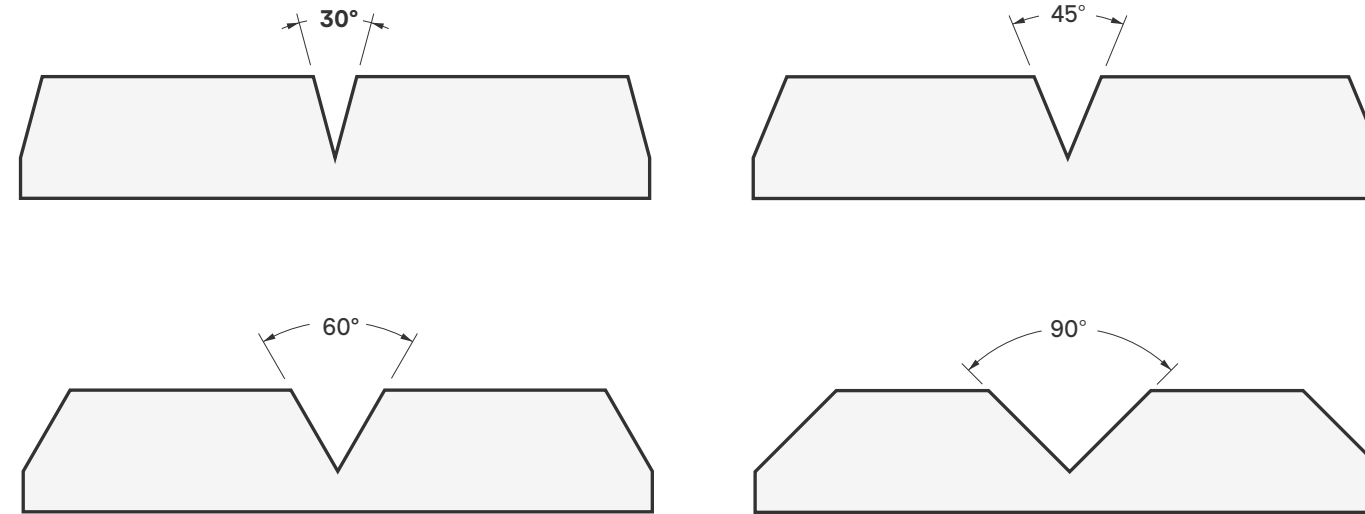

Groove™ Configuration

To change groove width, angle, and depth from the standard dimensions, use this table to configure unique measurements for your project.

		Depth (mm)										
		1	2	3	4	5	6	7	8	9	10	11
Angle (deg)	30					2.9	3.4	4.0	4.6	5.2	5.7	6.3
	45	2	3.1	4.1	5.2	6.2	7.2	8.3	9.3	10.3	11.4	
	60	2.4	3.6	4.8	6.0	7.2	8.4	9.6	10.8	12.0	13.2	
	90	4.1	6.2	8.3	10.4	12.4	14.5	16.6	18.6	20.7	22.8	

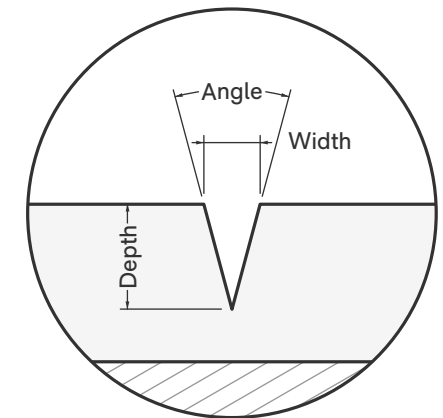



Detail Considerations

Trimming Panel

Groove panels can be cut on-site if required.
We recommend using a snap-blade knife and straight edge.

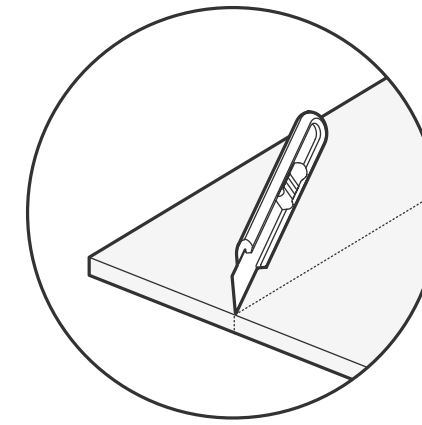

Power Outlets and Light Switches

Measure and cut out where the outlet would sit on the panel.
Apply the panel to the substrate and secure the outlet through the panel.

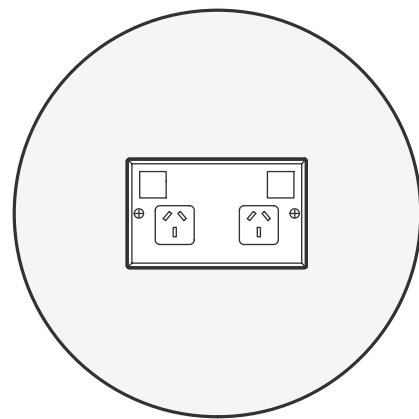

Internal Corners

We recommend a simple lap-join install. If the opposite end of your wall has an exposed edge, we recommend starting the install from that end, and cutting the final panel to fit into this lap join.

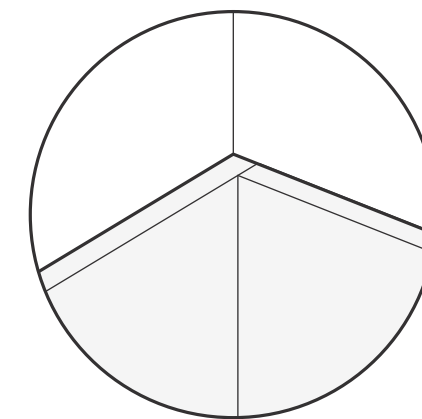

For further installation details, please refer to the Groove Installation Guide.



Colours

Cube™ Colours

Groove panels are available in the full range of Cube™ colours.



Pavilion



Opera



Parthenon



Senado



Beehive



Terrace



Canyon



Sargazo



Savoye



Colosseum



Rushmore



Flatiron



Cavalier

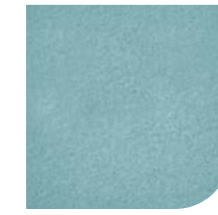

Falling Water



Muralla



Pinnacle



Acros



Highland



Gherkin



Tree House

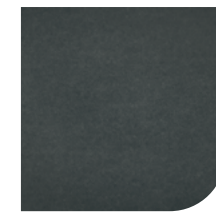

Caspian

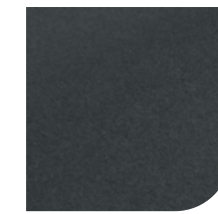

Empire

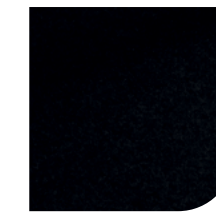

Petronas





Sound Materials

We're on a positive journey towards momentous change. It's about winning for the planet and its people, making a difference for healthy generations to come.

Sustainability is ingrained in everything we do, from fibre to finish. Our commitment to doing good now and in the future drives us to continuously evolve our practices, design with integrity, and take responsibility for the impact of our products. Our five sustainability pillars reflect this ethos, guiding our actions and shaping our decisions. Together, these pillars form a system that ensures our materials, products, and processes contribute meaningfully to a more sustainable world.



01



Climate change demands climate action

We are carbon neutral in everything we do.

02



Closing the loop

We are advocates for closing the loop on waste. We design with circularity front of mind.

03



Sustainable supply chain

We carefully select responsible suppliers and take action to mitigate unethical practices, and encourage good working conditions.

04



Supporting wellbeing in buildings

All our products are made using only safe materials. No harmful chemicals are present in our products.

05



Operating a business for purpose and profit

We strive to have a positive impact on our environment, our people, and the next generation.

Credentials

Sustainability isn't just a feature—it's a foundation. Our products are independently certified by trusted third-party certifications and labels to meet rigorous environmental and performance standards.

Our products also meet criteria for WELL, LEED, Green Star, and BREEAM building rating systems, helping you achieve certification for your project.



Declare





Our Journey to Nature Positive

We want to make a material difference to the planet and its people. That's why we're not resting on achieving carbon neutrality across the organisation and our products.

We're on a journey committed to Nature Positive, which ultimately delivers systems and products that contribute to biodiversity replenishment, carbon sequestration, and many positive environmental outcomes.

It's manufacturing that cares for human beings and the generations to come.

1967
Founded in Auckland, NZ, creating underfelt for the flooring industry.



1990
Established on-line recycling systems.

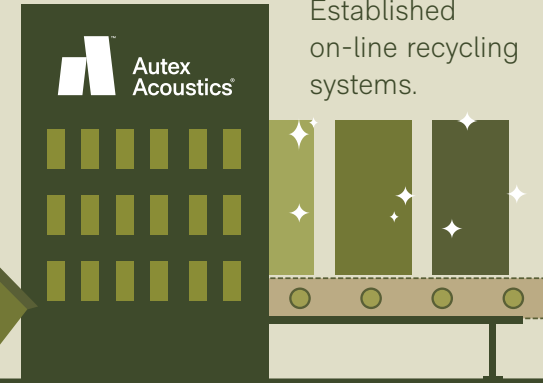

2020
Dematerialisation project, which reduced raw material use by 30% for core product.



2017
First Environmental Product Declarations (EPDs) were published and started measuring GHG emissions.



2012
Reclaimed waste trimmings, reducing raw material use and associated emissions.

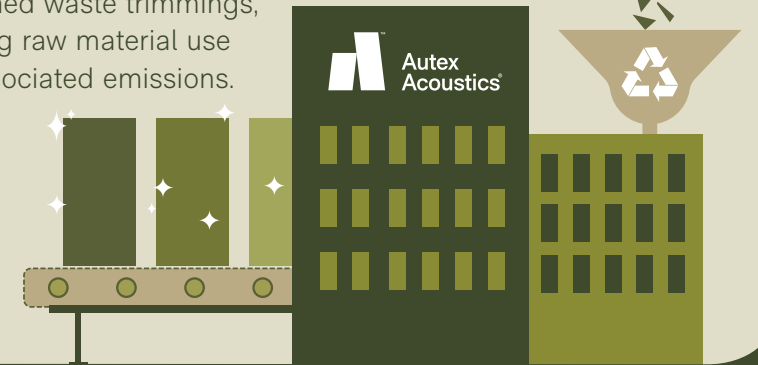

2021
We balanced all emissions from our acoustic products to zero.



2022
We balanced all emissions from our global operations to zero.



2025
We received the first NaturePositive+ Declaration in the construction industry for our first carbon negative product we launched in New Zealand. It uses a material with a -8.6 CO₂e carbon footprint.



Technical Information

Overview

NRC	0.45 - 0.80
Content	100% PET, min. 80% recycled
Form	Panel
Dimensions	1200mm x 2400mm
Thickness	12mm and 24mm
Origin	Made in New Zealand

Acoustic Performance

Groove is specifically designed to reduce and control reverberation and echo noise in building interiors.

Groove is made from Cube as the base material.

	Frequency (Hz)	125	250	500	1000	2000	4000	NRC
● 12mm Cube		0.05	0.10	0.30	0.65	0.90	0.95	0.45
● 12mm Cube (with 25mm air gap)		0.05	0.30	0.60	0.95	0.95	0.85	0.70
● 24mm Cube		0.05	0.20	0.60	0.90	1.00	1.00	0.70
● 24mm Cube (with 25mm air gap)		0.15	0.40	0.85	0.95	0.95	0.95	0.80

Fire Considerations

ISO 9705: 1993
 Classification: **Group 1-S**
 Fire test report available on request.

Ten Year Manufacturer's Guarantee

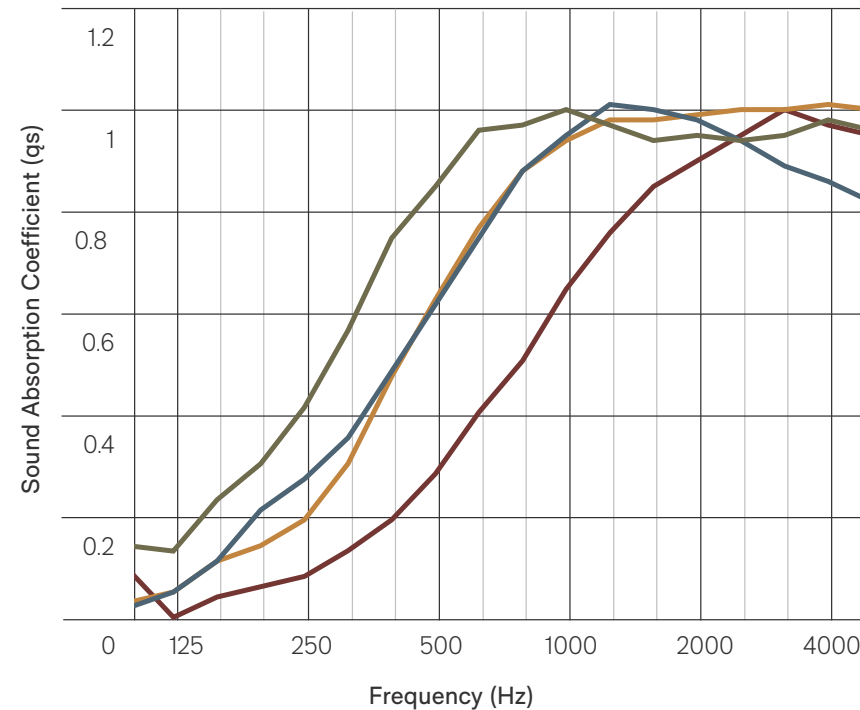

Product Specifications

Hard body impact There is no surface damage or penetration when subjected to hard body impacts. When adhered to 10mm plasterboard, the system can resist a 9 joule impact.

Soft body impact There is no surface damage or penetration when subjected to soft body impacts. When adhered to 10mm plasterboard, the system can resist a 70 joule impact.

Microbial resistance (ASTM G21-15):
 Growth rating: 0

Pattern
 Non-woven. No pattern repeat.

Colour fastness to light (ISO 105-B02:2014):
 Rating: 6

Determination of colourfastness to rubbing (ISO 105-X12:2016):
 Dry assessment: 4 - 5
 Wet assessment: 4 - 5

Average % of water vapour sorption by weight after four days: 0.4%

For care and maintenance guidance, view the product Care and Maintenance Guide.

