



Product: 30 Inch Gas Range in Black
Model Number: LRG3001UB / LRG3001UBLP

TECHNICAL DETAILS

Fuel Type	Natural Gas (LRG3001UB) Liquid Propane (LRG3001UBLP)
Installation Type	Freestanding
Color	Black
Amperage or Current (A)	15A
Volts (V)	120V
Frequency (Hz)	60Hz
Control Type	Knob Control
Plug Type	US 3-prong
Power Cord Length (in.)	59"

OVEN PERFORMANCE

Oven Capacity (cu. ft.)	4.55 cu. ft.
Cooking Modes	Bake, Conv Bake, Roast, Conv Roast, Broil
Bake Burner Power	18500BTU
Broil Burner Power	10000BTU
Convection	Commerical Convection
Oven Lights	1
Oven Racks	Telescopic Racks x2
Oven Rack Material	Chrome Plated
Baking Sheet Size	Fits 23" x 16" Baking sheet
Self Clean (Y/N)	No
Air Fry	No

FEATURES & BENEFITS

- + **High-Powered BTU Burner:** The high-powered 18,000 BTU burner provides fast, intense heat for creating large family meals and restaurant-quality dishes.
- + **Large Oven Capacity:** 4.55 cu. ft. oven capacity can accommodate multiple dishes at a time.
- + **Storage Space:** Storage drawer provides additional storage space for cooking trays and other kitchen utensils.
- + **Convection Fan:** Commercial convection fan provides controlled heat distribution for fast and efficient cooking.
- + **Even Heat Broiler:** Reflective gas tube broiler distributes heat evenly to sear your food and seal in the juices.
- + **Continuous Cast-Iron Grates:** Heavy-duty continuous cast-iron cooking grates that can handle any size cookware.
- + **Porcelain Spill Tray:** Single-piece black porcelain spill tray catches the mess and makes cleanup easy.
- + **Porcelain Interiors:** The gray porcelain oven interior adds a stylish touch and is easy to clean.



COOKTOP PERFORMANCE

Total Burners	5
[1] Front Left Burner	18,000 BTU
[2] Front Right Burner	8,000 BTU
[3] Rear Left Burner	4,000 BTU
[4] Rear Right Burner	6,000 BTU
[5] Middle (Oval)	9,000 BTU

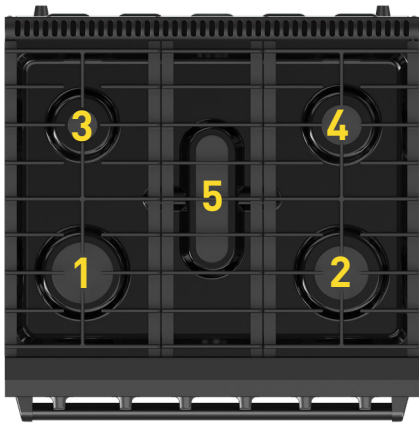

PRODUCT DIMENSIONS & WEIGHTS

Product Dimensions (WxDxH) (in.)	30" × 28-3/8" × 39-1/4"
Product Height (from bottom to top of back splash) (in.)	36-5/8" - 37-5/8"
Product Height (from bottom to top of side panel) (in.)	36-1/8" - 37-1/8"
Product Depth (from back panel to bullnose) (in.)	27-1/2"
Product Depth (from back panel to control panel) (in.)	27-3/4"
Product Depth (from back panel to side panel front) (in.)	24-3/4"
Cutout Dimensions (WxDxH) (in.)	30-1/8" × 24-3/4" × 36-1/4"
Adjustable Leg Sizes	Not to Exceed 1"
Net Weight (lbs.)	215
Gross Weight (lbs.)	258
Package Dimensions (WxDxH) (in.)	30" × 33" × 44-7/8"
Package Weight (lbs.)	258

ACCESSORIES (INCLUDED)

2 Standard Racks
1 Broiler Pan Set

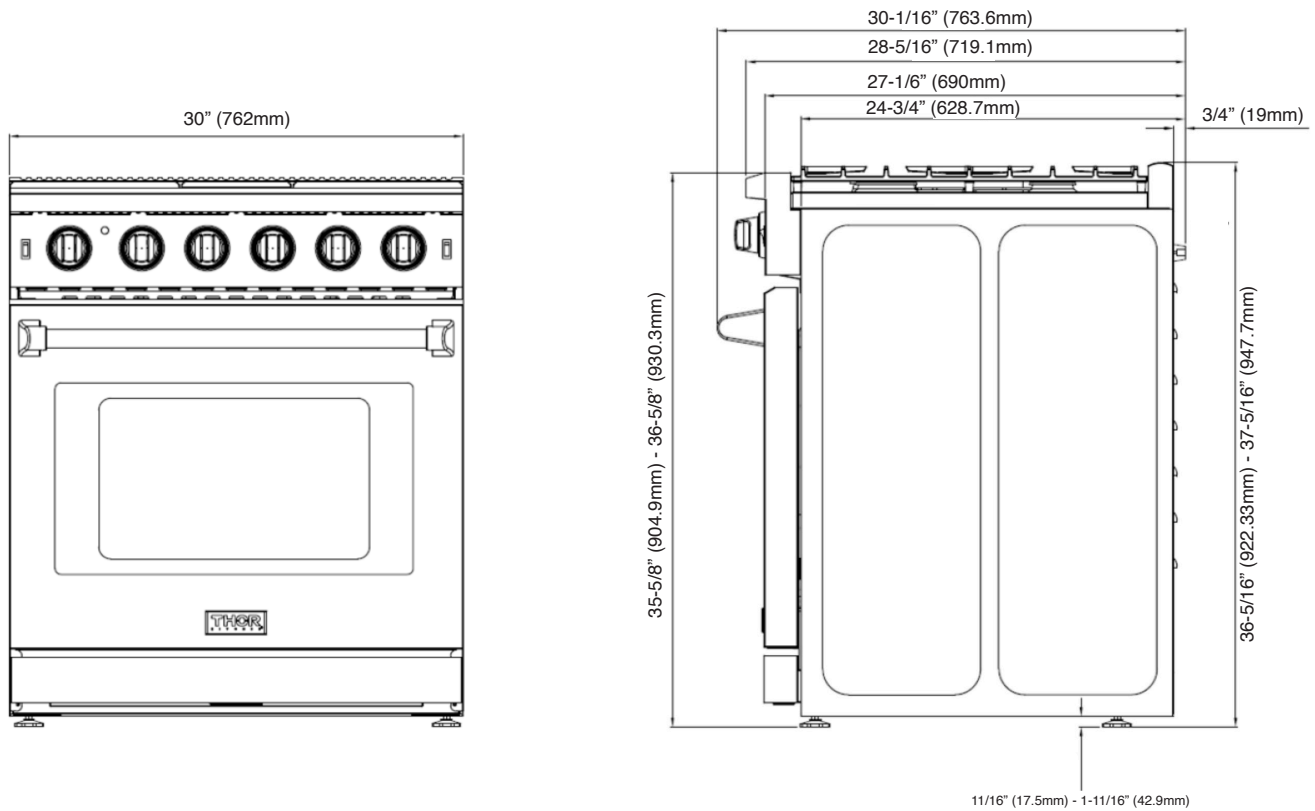

NG: Input Pressure: 7 inches,
Output Pressure: 5 inches
LP: Input Pressure: 11 inches
Output Pressure: 10 inches
Size of Regulator: 1/2 inch

