

NOVUM WALL RETAINING BLOCK- (NW-R)

Weight = 610 lb (277 kg) +/- 30 lb (13.6 kg)

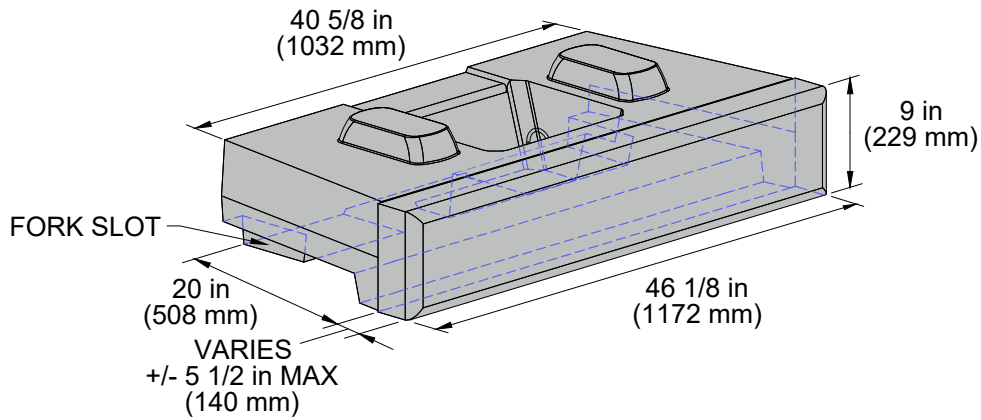

ISOMETRIC VIEW

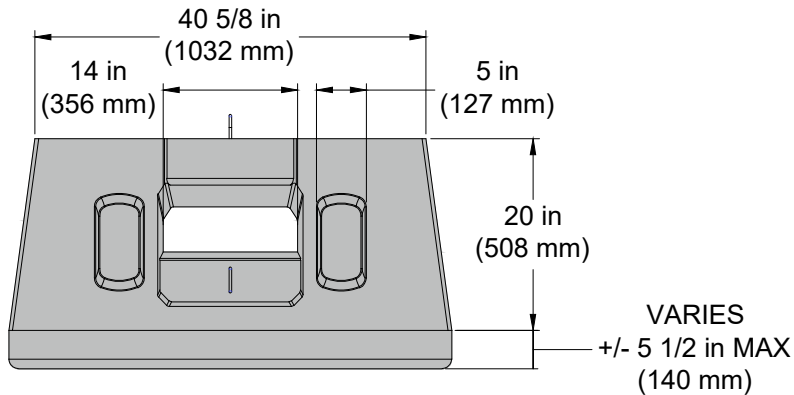

TOP VIEW

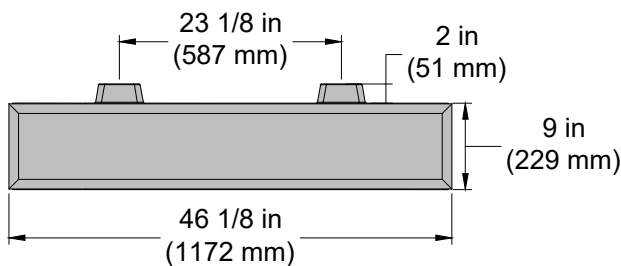

FRONT VIEW

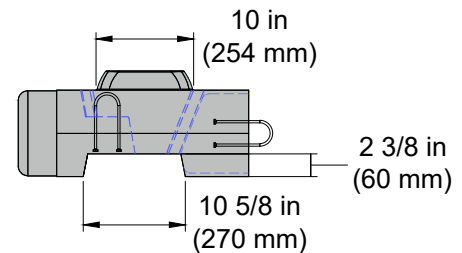

SIDE VIEW

Note:

1. Blocks are produced with multiple face texture options which vary in dimension (+/- 5 1/2 in (140 mm)).
2. Block weight is based on assumed concrete unit weight of 143 lb/ft³ (2290 kg/m³).
3. Block volume and weight depend on the block's face texture, construction tolerance, and concrete mix design. The values shown are averages.
4. This drawing is not to scale. Blocks are increased in size by a factor of 1.5.

DRAWN BY:	LBH
APPROVED BY:	DJC
DATE:	4-APR-2024
SHEET:	1 of 1

TITLE:	SCHEMATIC RETAINING BLOCK DRAWING
FILE:	

3890 CHARLEVOIX AVE, PETOSKEY, MI 49720
(866) 222-8400 ext 33010 • engineering@redi-rock.com • www.novumwall.com

NOVUM WALL HALF RETAINING BLOCK- (NW-R-H)

Weight = 323 lb (147 kg) +/- 15 lb (6.8 kg)

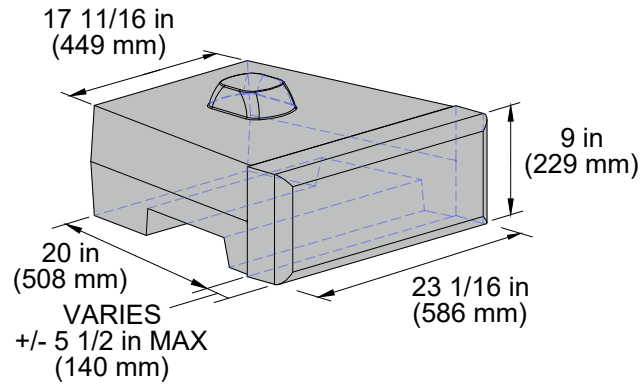

ISOMETRIC VIEW

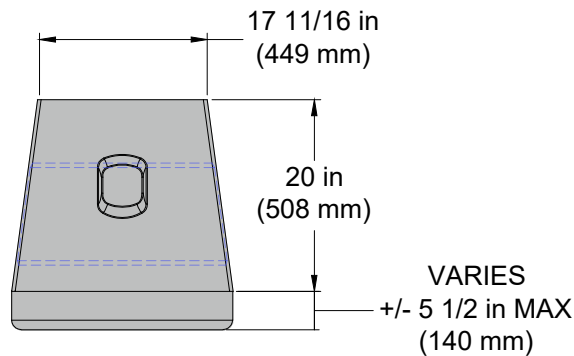

TOP VIEW

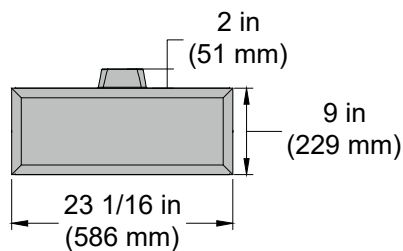

FRONT VIEW

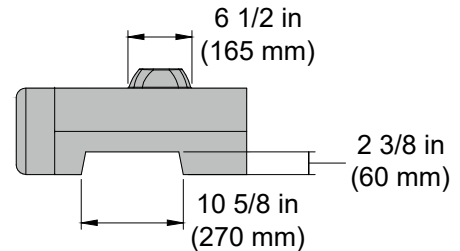

SIDE VIEW

Note:

1. Blocks are produced with multiple face texture options which vary in dimension (+/- 5 1/2 in (140 mm)).
2. Block weight is based on assumed concrete unit weight of 143 lb/ft³ (2290 kg/m³).
3. Block volume and weight depend on the block's face texture, construction tolerance, and concrete mix design. The values shown are averages.
4. This drawing is not to scale. Blocks are increased in size by a factor of 1.5.

DRAWN BY:	LBH
APPROVED BY:	DJC
DATE:	30-JUL-2024
SHEET:	1 of 1

TITLE:	SCHEMATIC HALF RETAINING BLOCK DRAWING
FILE:	Novum_Wall_Block_Library.dwg

NOVUM WALL™

3890 CHARLEVOIX AVE, PETOSKEY, MI 49720
 (866) 222-8400 ext 33010 • engineering@redi-rock.com • www.novumwall.com

NOVUM WALL RETAINING TOP BLOCK- (NW-R-T)

Weight = 475 lb (215 kg) +/- 30 lb (13.6 kg)

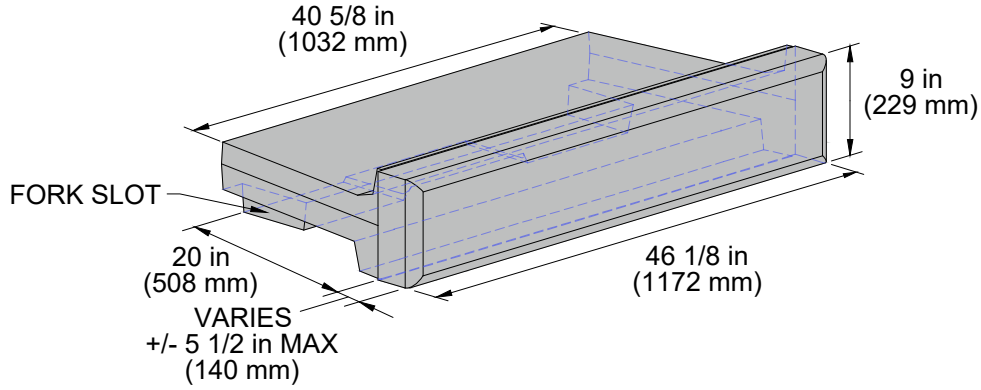

ISOMETRIC VIEW

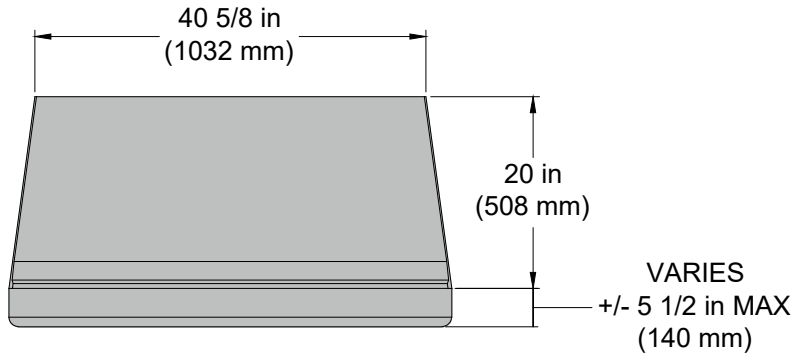

TOP VIEW

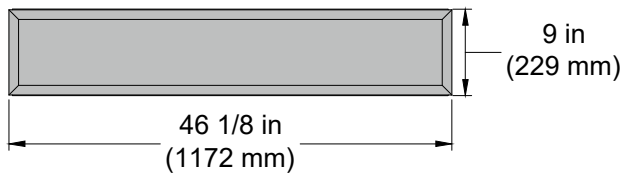

FRONT VIEW

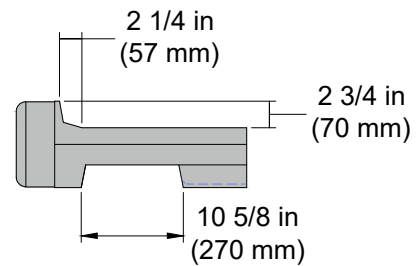

SIDE VIEW

Note:

1. Blocks are produced with multiple face texture options which vary in dimension (+/- 5 1/2 in (140 mm)).
2. Block weight is based on assumed concrete unit weight of 143 lb/ft³ (2290 kg/m³).
3. Block volume and weight depend on the block's face texture, construction tolerance, and concrete mix design. The values shown are averages.
4. This drawing is not to scale. Blocks are increased in size by a factor of 1.5.

DRAWN BY:	LBH
APPROVED BY:	DJC
DATE:	4-APR-2024
SHEET:	1 of 1

TITLE:	SCHEMATIC RETAINING TOP BLOCK DRAWING
FILE:	Novum_Wall_Block_Library.dwg

NOVUM WALL™

3890 CHARLEVOIX AVE, PETOSKEY, MI 49720
(866) 222-8400 ext 33010 • engineering@redi-rock.com • www.novumwall.com

NOVUM WALL HALF RETAINING TOP BLOCK- (NW-R-HT)

Weight = 275 lb (125 kg) +/- 15 lb (6.8 kg)

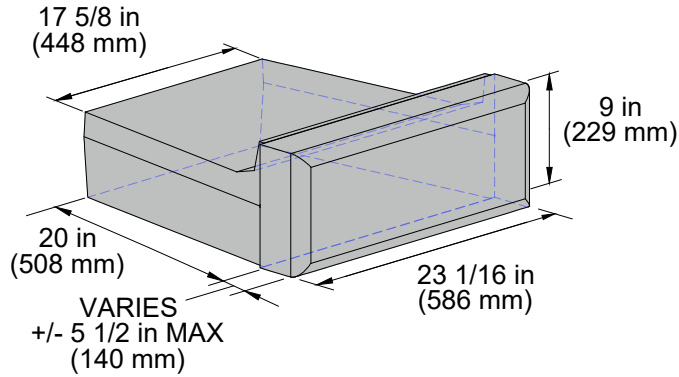

ISOMETRIC VIEW

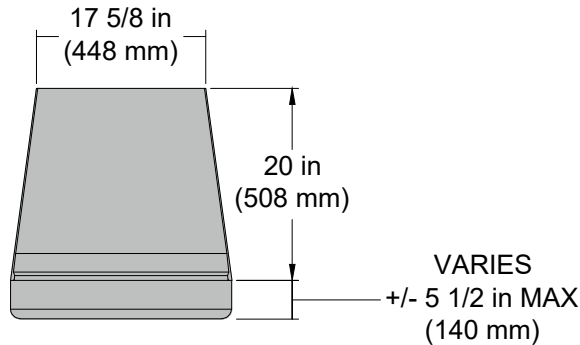

TOP VIEW

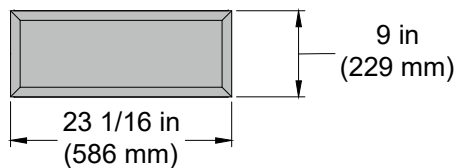

FRONT VIEW

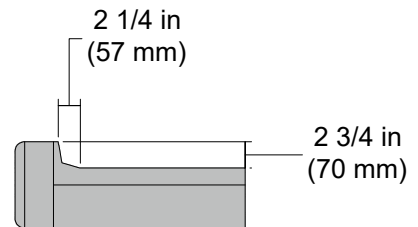

SIDE VIEW

Note:

1. Blocks are produced with multiple face texture options which vary in dimension (+/- 5 1/2 in (140 mm)).
2. Block weight is based on assumed concrete unit weight of 143 lb/ft³ (2290 kg/m³).
3. Block volume and weight depend on the block's face texture, construction tolerance, and concrete mix design. The values shown are averages.
4. This drawing is not to scale. Blocks are increased in size by a factor of 1.5.

DRAWN BY:	EGS
APPROVED BY:	LBH
DATE:	28-JAN-2025
SHEET:	1 of 1

TITLE:	SCHEMATIC HALF RETAINING TOP BLOCK DRAWING
FILE:	Novum_Wall_Block_Library.dwg

NOVUM WALL

3890 CHARLEVOIX AVE, PETOSKEY, MI 49720
(866) 222-8400 ext 33010 • engineering@redi-rock.com • www.novumwall.com

NOVUM WALL RETAINING CORNER A BLOCK- (NW-R-C-A)

Weight = 575 lb (261 kg) +/- 30 lb (13.6 kg)

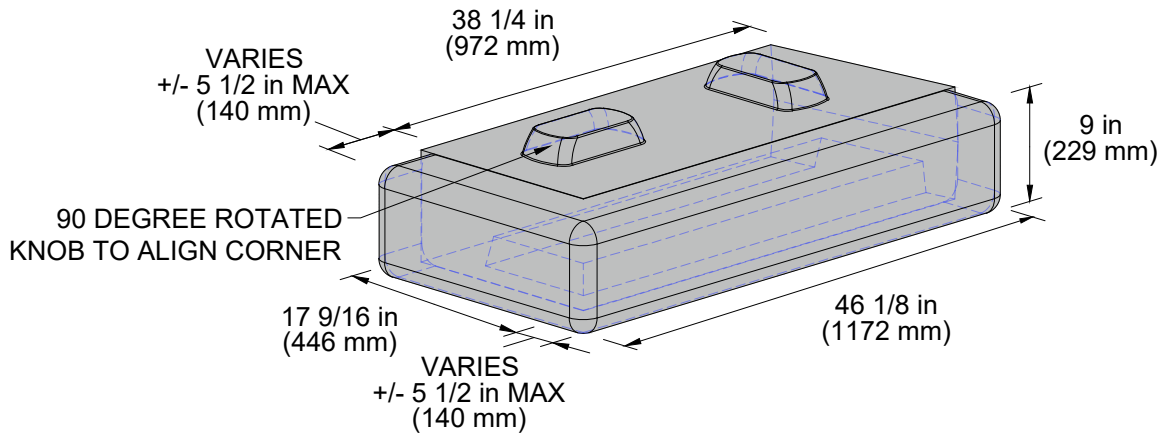

ISOMETRIC VIEW

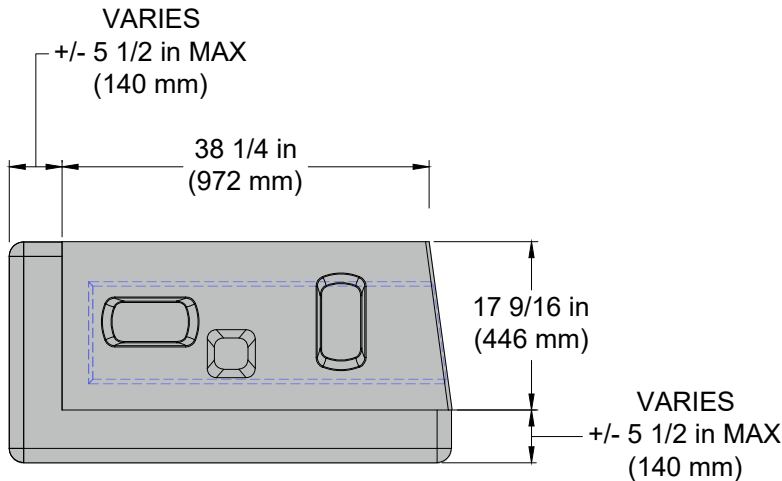

TOP VIEW

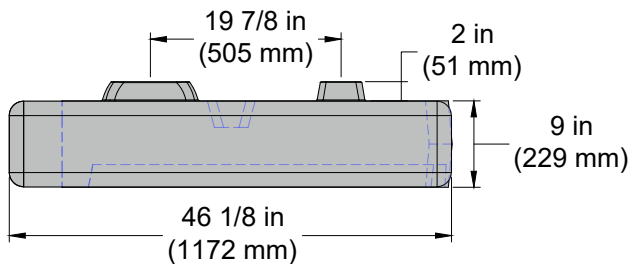

FRONT VIEW

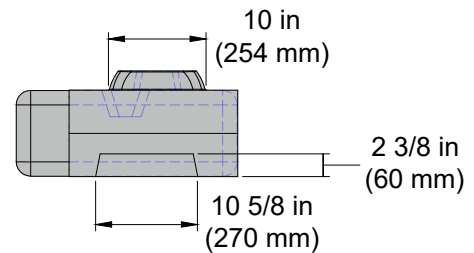

SIDE VIEW

Note:

1. Blocks are produced with multiple face texture options which vary in dimension (+/- 5 1/2 in (140 mm)).
2. Block weight is based on assumed concrete unit weight of 143 lb/ft³ (2290 kg/m³).
3. Block volume and weight depend on the block's face texture, construction tolerance, and concrete mix design. The values shown are averages.
4. This drawing is not to scale. Blocks are increased in size by a factor of 1.5.

DRAWN BY:	LBH
APPROVED BY:	DJC
DATE:	28-JAN-2025
SHEET:	1 of 1

TITLE:	SCHEMATIC RETAINING CORNER A BLOCK DRAWING
FILE:	Novum_Wall_Block_Library.dwg

NOVUM WALL

3890 CHARLEVOIX AVE, PETOSKEY, MI 49720
 (866) 222-8400 ext 33010 • engineering@redi-rock.com • www.novumwall.com

NOVUM WALL RETAINING TOP CORNER A BLOCK- (NW-R-TC-A)

Weight = 425 lb (193 kg) +/- 30 lb (13.6 kg)

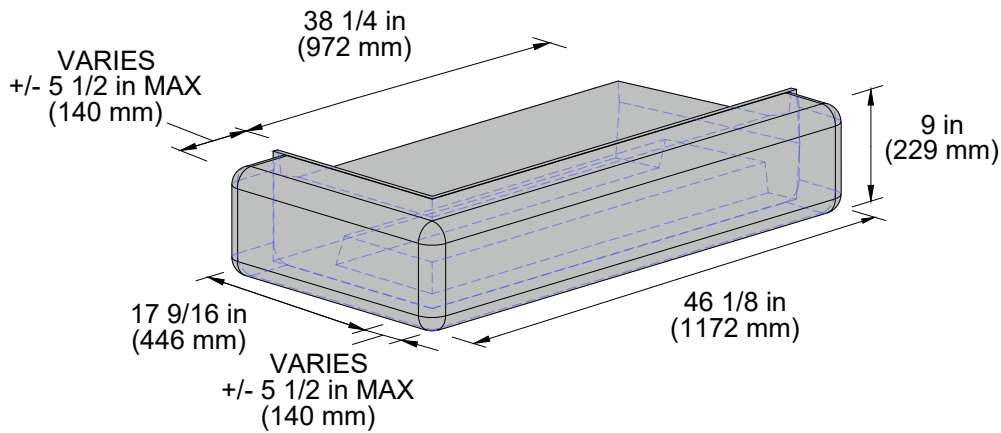

ISOMETRIC VIEW

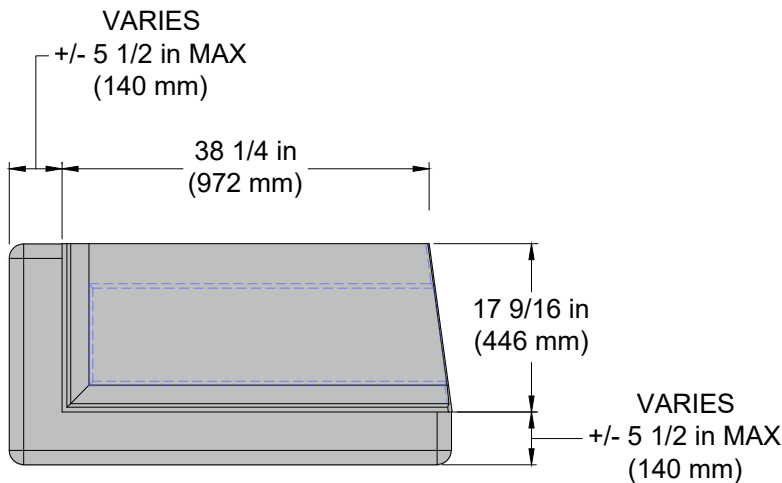

TOP VIEW

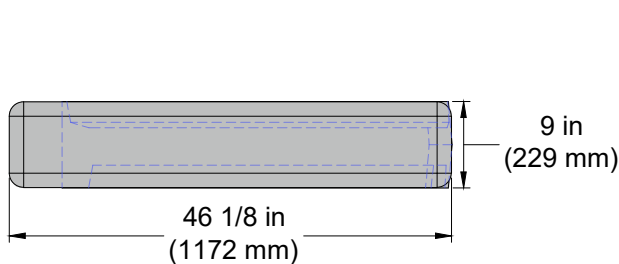

FRONT VIEW

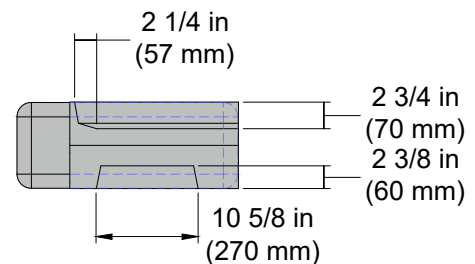

SIDE VIEW

Note:

1. Blocks are produced with multiple face texture options which vary in dimension (+/- 5 1/2 in (140 mm)).
2. Block weight is based on assumed concrete unit weight of 143 lb/ft³ (2290 kg/m³).
3. Block volume and weight depend on the block's face texture, construction tolerance, and concrete mix design. The values shown are averages.
4. This drawing is not to scale. Blocks are increased in size by a factor of 1.5.

DRAWN BY:	LBH
APPROVED BY:	DJC
DATE:	28-JAN-2025
SHEET:	1 of 1

TITLE:	SCHEMATIC RETAINING TOP CORNER A BLOCK DRAWING
FILE:	Novum_Wall_Block_Library.dwg

NOVUM WALL

3890 CHARLEVOIX AVE, PETOSKEY, MI 49720
 (866) 222-8400 ext 33010 • engineering@redi-rock.com • www.novumwall.com

NOVUM WALL RETAINING CORNER B BLOCK- (NW-R-C-B)

Weight = 575 lb (261 kg) +/- 30 lb (13.6 kg)

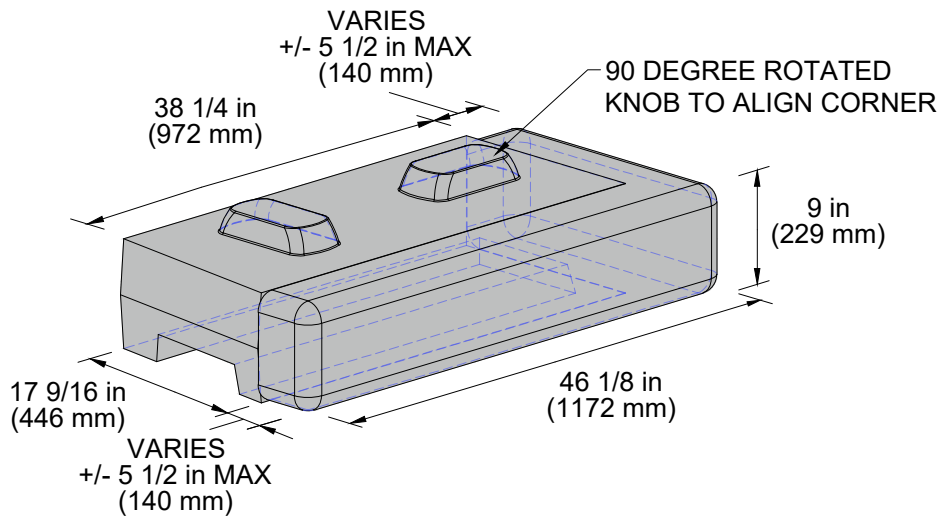

ISOMETRIC VIEW

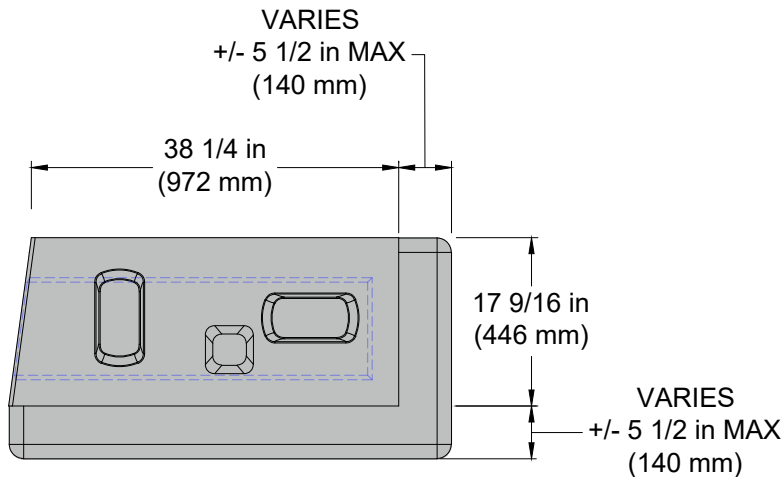

TOP VIEW

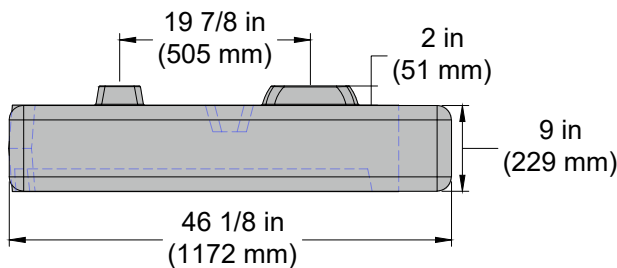

FRONT VIEW

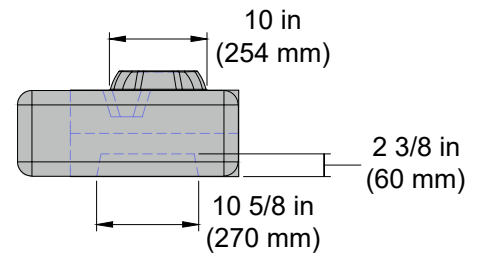

SIDE VIEW

Note:

1. Blocks are produced with multiple face texture options which vary in dimension (+/- 5 1/2 in (140 mm)).
2. Block weight is based on assumed concrete unit weight of 143 lb/ft³ (2290 kg/m³).
3. Block volume and weight depend on the block's face texture, construction tolerance, and concrete mix design. The values shown are averages.
4. This drawing is not to scale. Blocks are increased in size by a factor of 1.5.

DRAWN BY:	LBH
APPROVED BY:	DJC
DATE:	28-JAN-2025
SHEET:	1 of 1

TITLE:	SCHEMATIC RETAINING CORNER B BLOCK DRAWING
FILE:	Novum_Wall_Block_Library.dwg

NOVUM WALL

3890 CHARLEVOIX AVE, PETOSKEY, MI 49720
(866) 222-8400 ext 33010 • engineering@redi-rock.com • www.novumwall.com

NOVUM WALL RETAINING TOP CORNER B BLOCK- (NW-R-TC-B)

Weight = 425 lb (193 kg) +/- 30 lb (13.6 kg)

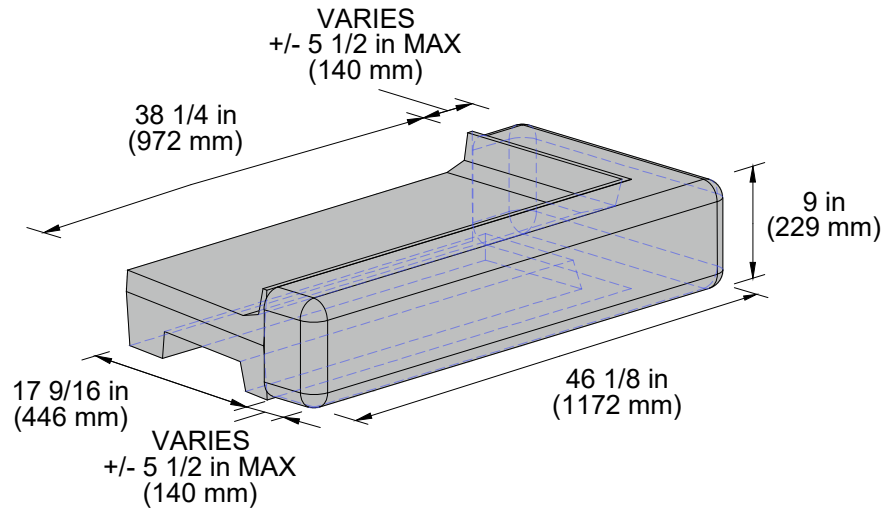

ISOMETRIC VIEW

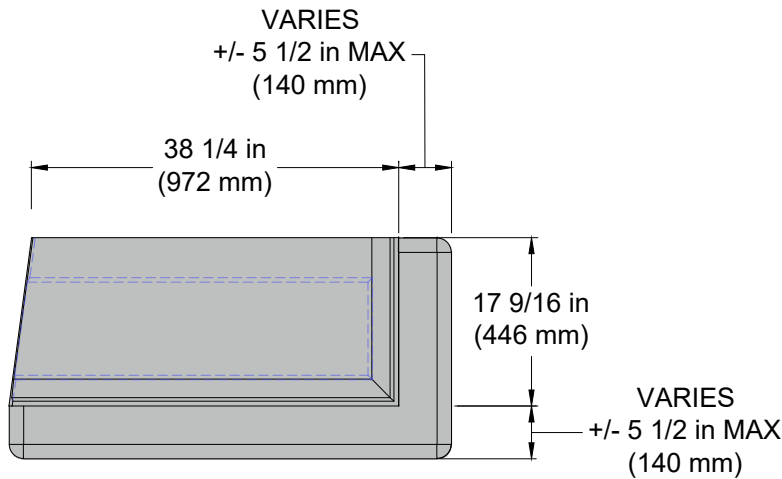

TOP VIEW

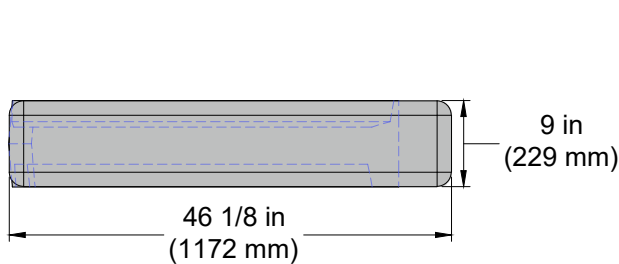

FRONT VIEW

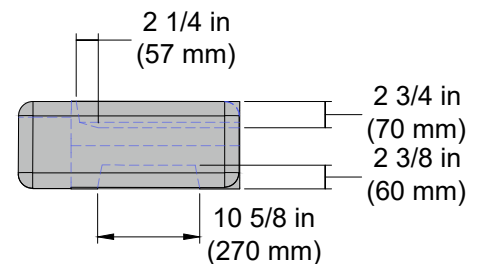

SIDE VIEW

Note:

1. Blocks are produced with multiple face texture options which vary in dimension (+/- 5 1/2 in (140 mm)).
2. Block weight is based on assumed concrete unit weight of 143 lb/ft³ (2290 kg/m³).
3. Block volume and weight depend on the block's face texture, construction tolerance, and concrete mix design. The values shown are averages.
4. This drawing is not to scale. Blocks are increased in size by a factor of 1.5.

DRAWN BY:	LBH
APPROVED BY:	DJC
DATE:	28-JAN-2025
SHEET:	1 of 1

TITLE:	SCHEMATIC RETAINING TOP CORNER B BLOCK DRAWING
FILE:	Novum_Wall_Block_Library.dwg

NOVUM WALL

3890 CHARLEVOIX AVE, PETOSKEY, MI 49720
 (866) 222-8400 ext 33010 • engineering@redi-rock.com • www.novumwall.com

NOVUM WALL TWO-SIDED CAP BLOCK- (NW-C-2)

Weight = 385 lb (175 kg) +/- 10 lb (4.5 kg)

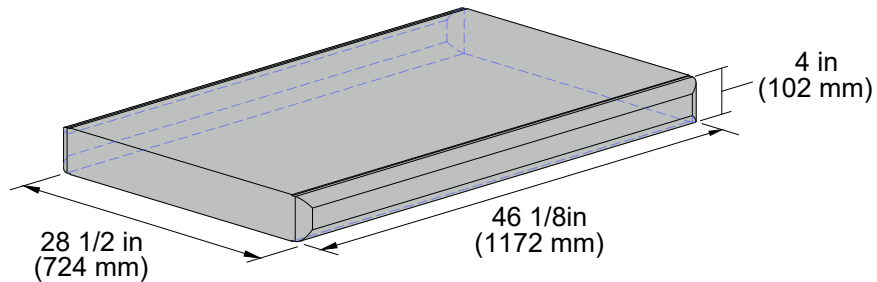

ISOMETRIC VIEW

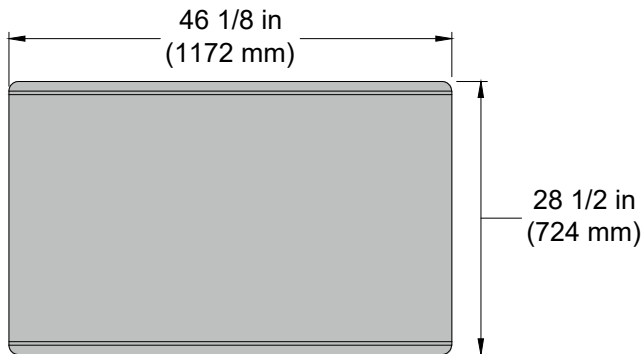

TOP VIEW



FRONT VIEW

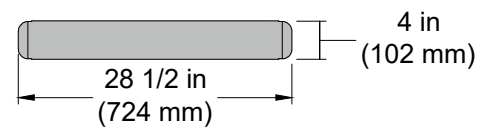

SIDE VIEW

Note:

1. Block weight is based on assumed concrete unit weight of 143 lb/ft³ (2290 kg/m³).
2. Block volume and weight depend on the block's face texture, construction tolerance, and concrete mix design. The values shown are averages.
3. This drawing is not to scale. Blocks are increased in size by a factor of 1.5.

DRAWN BY:	LBH
APPROVED BY:	DJC
DATE:	4-APR-2024
SHEET:	1 of 1

TITLE:	SCHEMATIC TWO-SIDED CAP BLOCK DRAWING
FILE:	Novum_Wall_Block_Library.dwg

NOVUM WALL

3890 CHARLEVOIX AVE, PETOSKEY, MI 49720
(866) 222-8400 ext 33010 • engineering@redi-rock.com • www.novumwall.com

NOVUM WALL THREE-SIDED CAP BLOCK- (NW-C-3)

Weight = 426 lb (193 kg) +/- 10 lb (4.5 kg)

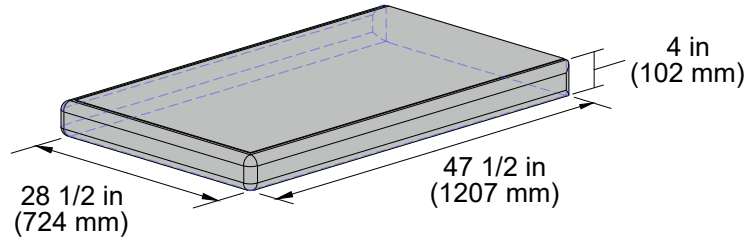

ISOMETRIC VIEW

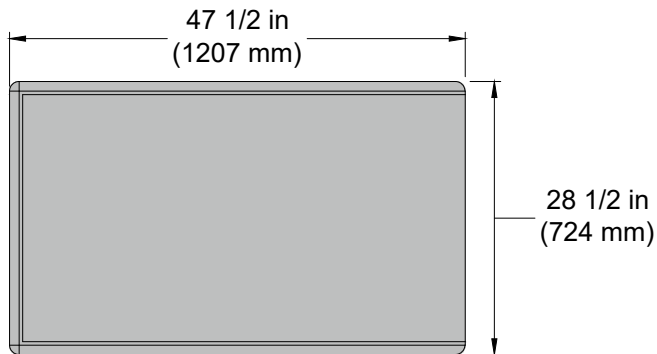

TOP VIEW



FRONT VIEW

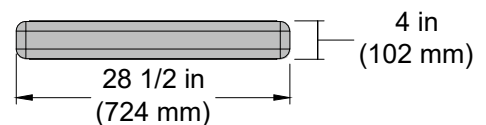

SIDE VIEW

Note:

1. Block weight is based on assumed concrete unit weight of 143 lb/ft³ (2290 kg/m³).
2. Block volume and weight depend on the block's face texture, construction tolerance, and concrete mix design. The values shown are averages.
3. This drawing is not to scale. Blocks are increased in size by a factor of 1.5.

DRAWN BY:	LBH
APPROVED BY:	DJC
DATE:	4-APR-2024
SHEET:	1 of 1

TITLE:	SCHEMATIC THREE-SIDED CAP BLOCK DRAWING
FILE:	Novum_Wall_Block_Library.dwg

NOVUM WALL

3890 CHARLEVOIX AVE, PETOSKEY, MI 49720
(866) 222-8400 ext 33010 • engineering@redi-rock.com • www.novumwall.com

NOVUM WALL FREESTANDING BLOCK- (NW-F)

Weight = 514 lb (233 kg) +/- 30 lb (13.6 kg)

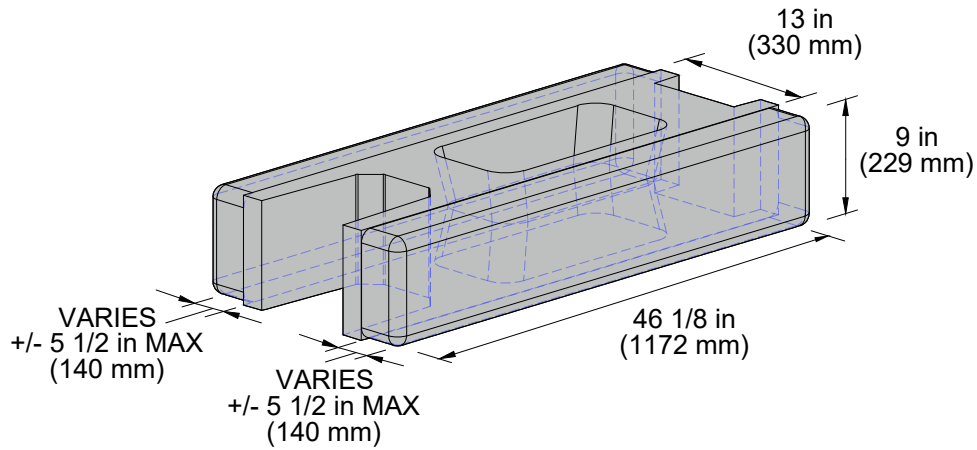

ISOMETRIC VIEW

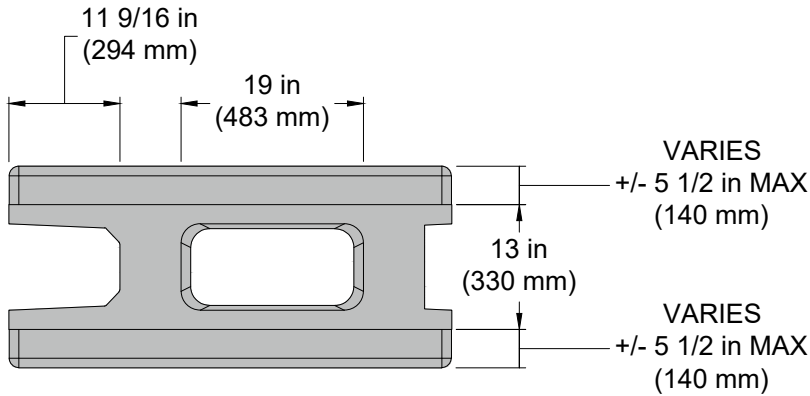

TOP VIEW

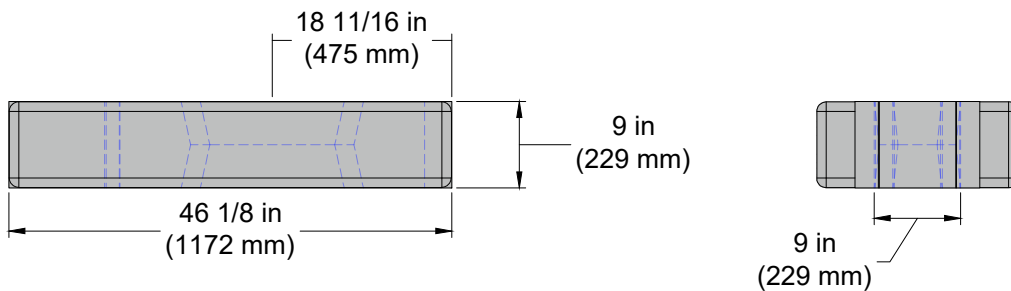

FRONT VIEW

SIDE VIEW

Note:

1. Blocks are produced with multiple face texture options which vary in dimension (+/- 5 1/2 in (140 mm)).
2. Block weight is based on assumed concrete unit weight of 143 lb/ft³ (2290 kg/m³).
3. Block volume and weight depend on the block's face texture, construction tolerance, and concrete mix design. The values shown are averages.
4. This drawing is not to scale. Blocks are increased in size by a factor of 1.5.

DRAWN BY:	EGS
APPROVED BY:	LBH
DATE:	28-JAN-2025
SHEET:	1 of 1

TITLE:	SCHEMATIC FREESTANDING BLOCK DRAWING
FILE:	Novum_Wall_Block_Library.dwg

NOVUM WALL

3890 CHARLEVOIX AVE, PETOSKEY, MI 49720
(866) 222-8400 ext 33010 • engineering@redi-rock.com • www.novumwall.com

NOVUM WALL FREESTANDING CORNER BLOCK- (NW-F-C)

Weight = 573 lb (260 kg) +/- 30 lb (13.6 kg)

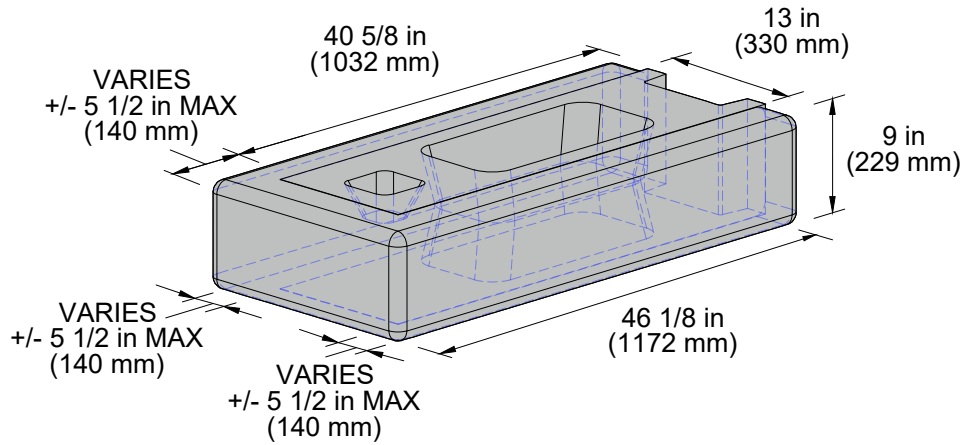

ISOMETRIC VIEW

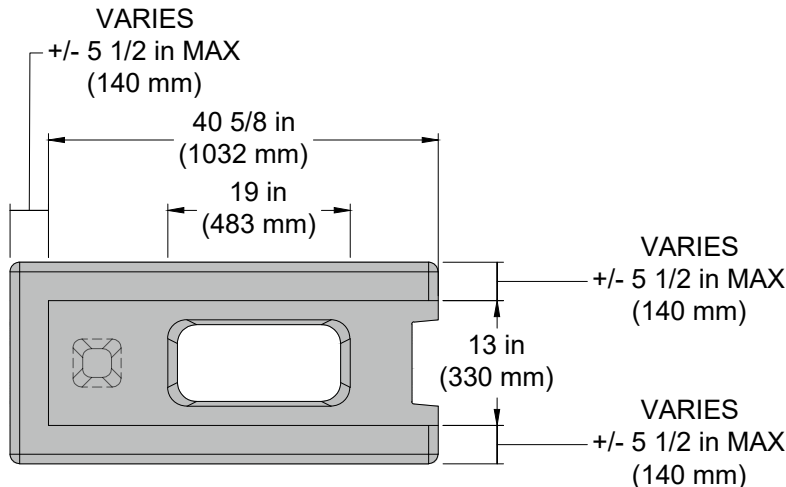

TOP VIEW

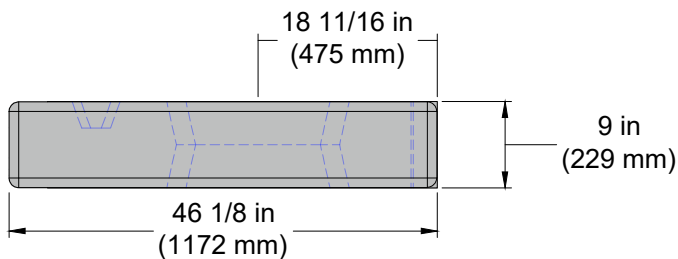

FRONT VIEW

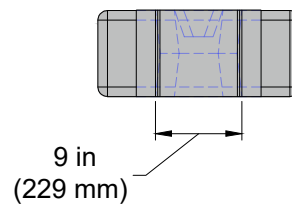

SIDE VIEW

Note:

1. Blocks are produced with multiple face texture options which vary in dimension (+/- 5 1/2 in (140 mm)).
2. Block weight is based on assumed concrete unit weight of 143 lb/ft³ (2290 kg/m³).
3. Block volume and weight depend on the block's face texture, construction tolerance, and concrete mix design. The values shown are averages.
4. This drawing is not to scale. Blocks are increased in size by a factor of 1.5.

DRAWN BY:	EGS
APPROVED BY:	LBH
DATE:	28-JAN-2025
SHEET:	1 of 1

TITLE:	SCHEMATIC FREESTANDING CORNER BLOCK DRAWING
FILE:	Novum_Wall_Block_Library.dwg

NOVUM WALL

3890 CHARLEVOIX AVE, PETOSKEY, MI 49720
 (866) 222-8400 ext 33010 • engineering@redi-rock.com • www.novumwall.com

NOVUM WALL HALF FREESTANDING CORNER BLOCK- (NW-F-HC)

Weight = 324 lb (147 kg) +/- 15 lb (6.8 kg)

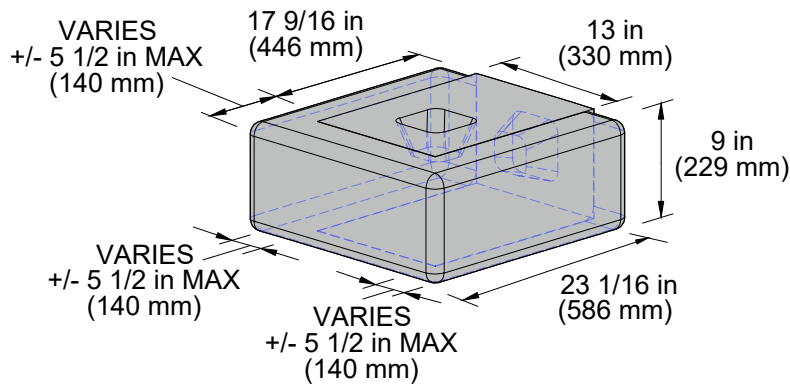

ISOMETRIC VIEW

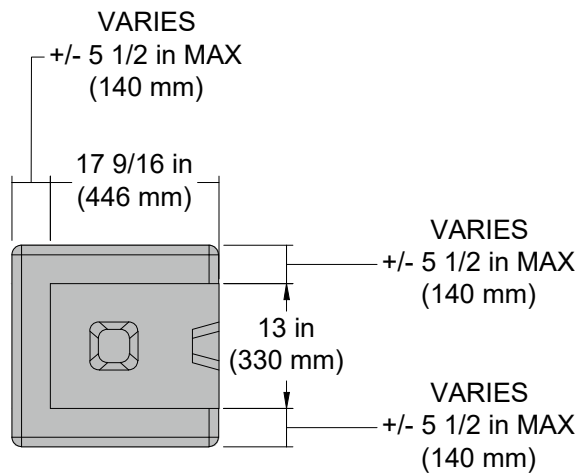

TOP VIEW

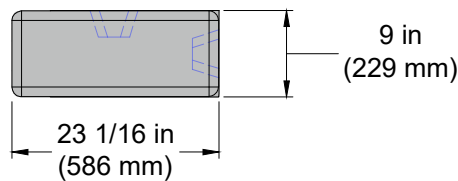

FRONT VIEW

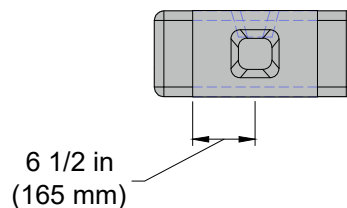

SIDE VIEW

Note:

1. Blocks are produced with multiple face texture options which vary in dimension (+/- 5 1/2 in (140 mm)).
2. Block weight is based on assumed concrete unit weight of 143 lb/ft³ (2290 kg/m³).
3. Block volume and weight depend on the block's face texture, construction tolerance, and concrete mix design. The values shown are averages.
4. This drawing is not to scale. Blocks are increased in size by a factor of 1.5.

DRAWN BY:	EGS
APPROVED BY:	LBH
DATE:	28-JAN-2025
SHEET:	1 of 1

TITLE:	SCHEMATIC HALF FREESTANDING CORNER BLOCK DRAWING
FILE:	Novum_Wall_Block_Library.dwg

NOVUM WALL

3890 CHARLEVOIX AVE, PETOSKEY, MI 49720
 (866) 222-8400 ext 33010 • engineering@redi-rock.com • www.novumwall.com