

TEST REPORT:

NOVUM WALL® RETAINING BLOCK

FRICITION CONNECTION STRENGTH WITH MIRAGRID 5XT REINFORCEMENT

Tested By:

Aster Brands Testing Laboratory
6328 Ferry Ave.
Charlevoix, Michigan 49720
Phone: 866-222-8400

Project Number: 34-B

Report Issued: August 8, 2024

ASTERBRANDS



REDI*ROCK®

ROSETTA®

pole base®

1.0 Introduction

This report presents the results of a laboratory testing project that was performed to evaluate the connection strength between Novum Wall® retaining blocks and Miragrid® 5XT geogrid utilizing a friction connection. The testing was performed by Aster Brands personnel, under the supervision of Aster Brands engineers at its testing facility located in Charlevoix, Michigan in May 2024. Novum Wall® is an Aster Brands company.

2.0 Purpose

The objective of the test series for this project was to define the connection strength capacity of Novum Wall® retaining blocks with geogrid inclusion in a frictional connection under varying normal loads using a large testing frame.

3.0 Materials

Novum Wall® blocks are wet-cast concrete, precast modular block (PMB) units with a consistent height of 9 in (229 mm), and a width of 24 in (610 mm) plus the face texture of variation of 1-1/2 in (38 mm). The length of the block is 46-1/8 in (1172 mm). Standard block dimensions are as shown in **Figure 1** below. The blocks are manufactured from wet-cast, first purpose, air-entrained, non-reconstituted, structural grade concrete mixes in accordance with ASTM C94 or ASTM C685. They have a minimum specified 28-day compressive strength of 4,000 psi (27.6 MPa) and weigh approximately 610 lb (277 kg) +/- 30 lb (13.6 kg).

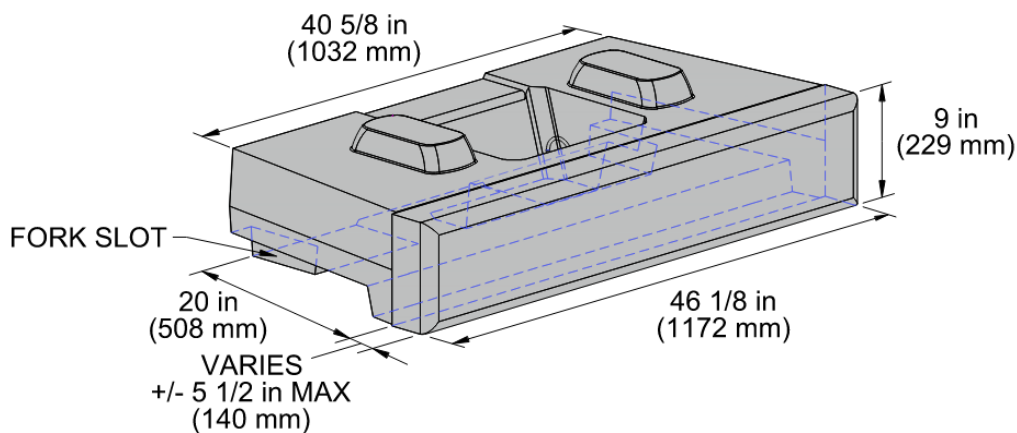

Figure 1 – Novum Wall® Block Dimensions

Shear engagement between subsequent rows of blocks is achieved by two trapezoidal shaped shear knobs protruding from the top of the block that interlock with a groove cast into the bottom of the block above, as well as friction. The shear knobs also set the wall face batter at a nominal value of approximately 5.2 degrees, so the setback between two rows of blocks is approximately (13/16 in (20 mm)). Blocks are designed to be dry stacked in a running bond configuration with the vertical joints offset, or staggered, by half of a block length.

Blocks used for this series of testing were produced by Truemont Materials at its Green Cove Springs, Florida facility. The blocks were produced in August 2023 and cured for 252 to 322 days prior to testing. All test blocks had compressive strength values at the time of testing above the minimum specified 28-day value for Novum Wall® blocks of 4,000 psi (27.6 MPa). No adjustments for compressive strength were made to the test results presented in this report.

The geogrid reinforcements used for these tests consisted of high molecular weight, high tenacity polyester multifilament yarns woven in tension and finished with a PVC coating. Specifically, samples of Solmax Mirafi® Miragrid® 5XT Lot # 20240102-2-1 were cut to fit the interface area between the blocks. Published values for the mechanical and physical properties of this product are available on the manufacturer's website. The index strength of the roll from which samples were cut was 5,356 lb/ft (78.2 kN/m), (data provided by the Manufacturer).

4.0 Test Apparatus

All tests were completed in a high-capacity structural testing frame located at the Aster Brand testing facilities in Charlevoix, Michigan, USA. This testing frame consists of a reconfigurable, steel reaction frame mounted to a 40-inch (1.0 m) thick solid concrete "strong floor".

Testing forces were induced by a precision hydraulic actuator system. The system is capable of providing up to 12 in (300 mm) of travel movement and a maximum of 150,000 lb force (670 kN) simultaneously in two directions using two separate hydraulic pump systems. This allows for precise control of both horizontal and vertical loading. The hydraulic systems are controlled by high-precision directional flow control, needle, and pressure relief valves.

Forces, pressures, and displacements were recorded with electronic sensing devices. Forces were measured with load cells mounted to the ends of the hydraulic cylinders and pushing directly on the block. Displacements were measured with an integral LDT sensor mounted inside the horizontal hydraulic cylinder.

All measurements were recorded with a National Instruments cDAQ data acquisition module and Labview data acquisition software. Data was recorded at a minimum of one datum per sensor per second.

5.0 Methodology

Friction connection strength testing was completed in general accordance with ASTM D6638 "Standard Test Method for Determining Connection Strength Between Geosynthetic Reinforcement and Segmental Concrete Units (Modular Concrete Blocks)". In this test method, one block is set on top of two blocks in a staggered, running bond pattern. The block cores and void space between blocks are filled with crushed stone and a layer of geogrid is inserted between the two layers of blocks. The base blocks are firmly fixed, and a horizontal tensile load is applied to the geogrid using a clamp. A normal load is applied vertically on top of the top block to simulate varied wall heights.

The tension load is applied until failure to determine the peak connection strength capacity of the geogrid between the block units. A steel beam and plates with rubber pads are used to spread the normal load evenly across the surface of the top block. Tests are run until grid rupture or pullout resulting in a significant reduction in the applied load. An overview of the test set-up and the configuration of the components is shown in **Figure 2**.

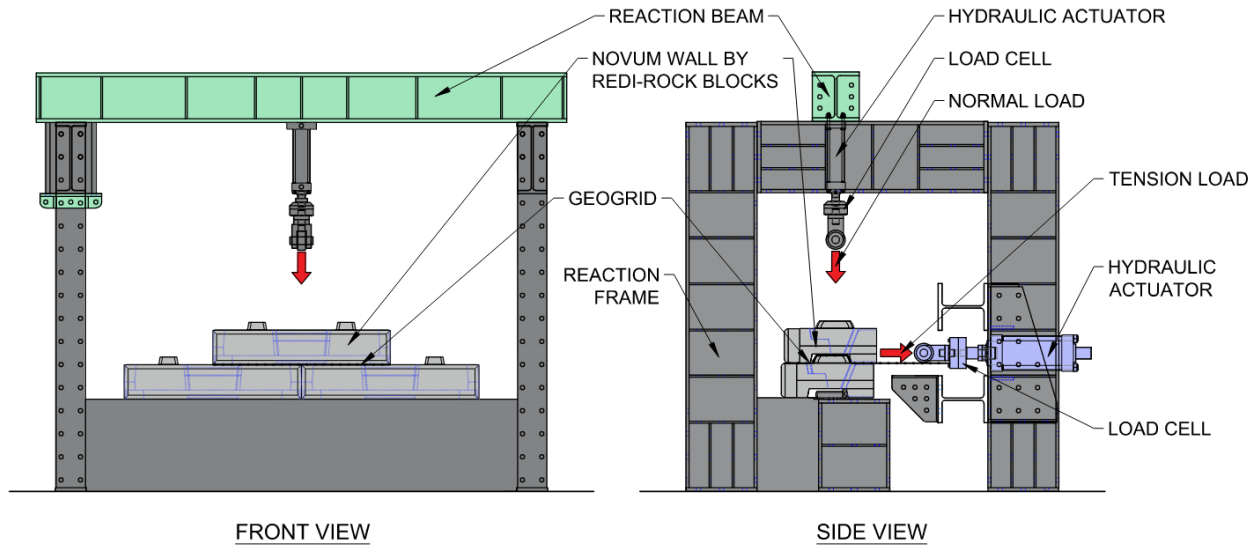

Figure 2 – Schematic test frame set-up

All connection strength tests were taken to the point of maximum tensile load. For this testing program, normal load levels were varied from 137 to 6,255 lb/ft (2.0 to 91.3 kN/m) to simulate the performance of the block to geogrid connection at different vertical locations in a wall cross-section. These values correspond to wall heights ranging from approximately 1 to 25 ft (0.3 to 7.6 m). Additional tests were run at the same nominal normal load near the middle of the range of normal loads to check the repeatability of the testing protocol.

Geogrid samples were preloaded with a tension load of approximately 100 lb (0.4 kN) to set and align the geogrid within the block interface and remove any slack in the geogrid. Displacement was measured at the point of load by the integral LDT sensor mounted inside the horizontal hydraulic cylinder. The displacement rate (velocity) at which the load was applied to the geogrid was manually controlled with an average rate of displacement of 2 in/min (51 mm/min).

6.0 Laboratory Test Results

All tests resulted in elongation of the geogrid reinforcement and two different failure modes were observed during the testing program. The first failure mode included tests imposing low normal loads (approximately 400 lb/ft (5.8 kN/m) or less), where the geogrid pulled out from between the blocks, but individual longitudinal members remained intact, as shown in **Figure 3**. The second failure mode occurred typically in larger normal loads, where longitudinal members of the geogrid reinforcement were ruptured at the shear knob location on the block, as shown in **Figure 4**.



Figure 3 – Geogrid elongation and pullout



Figure 4 – Geogrid elongation and rupture

Block displacement plotted against horizontal tension loads is shown in **Figure 5**

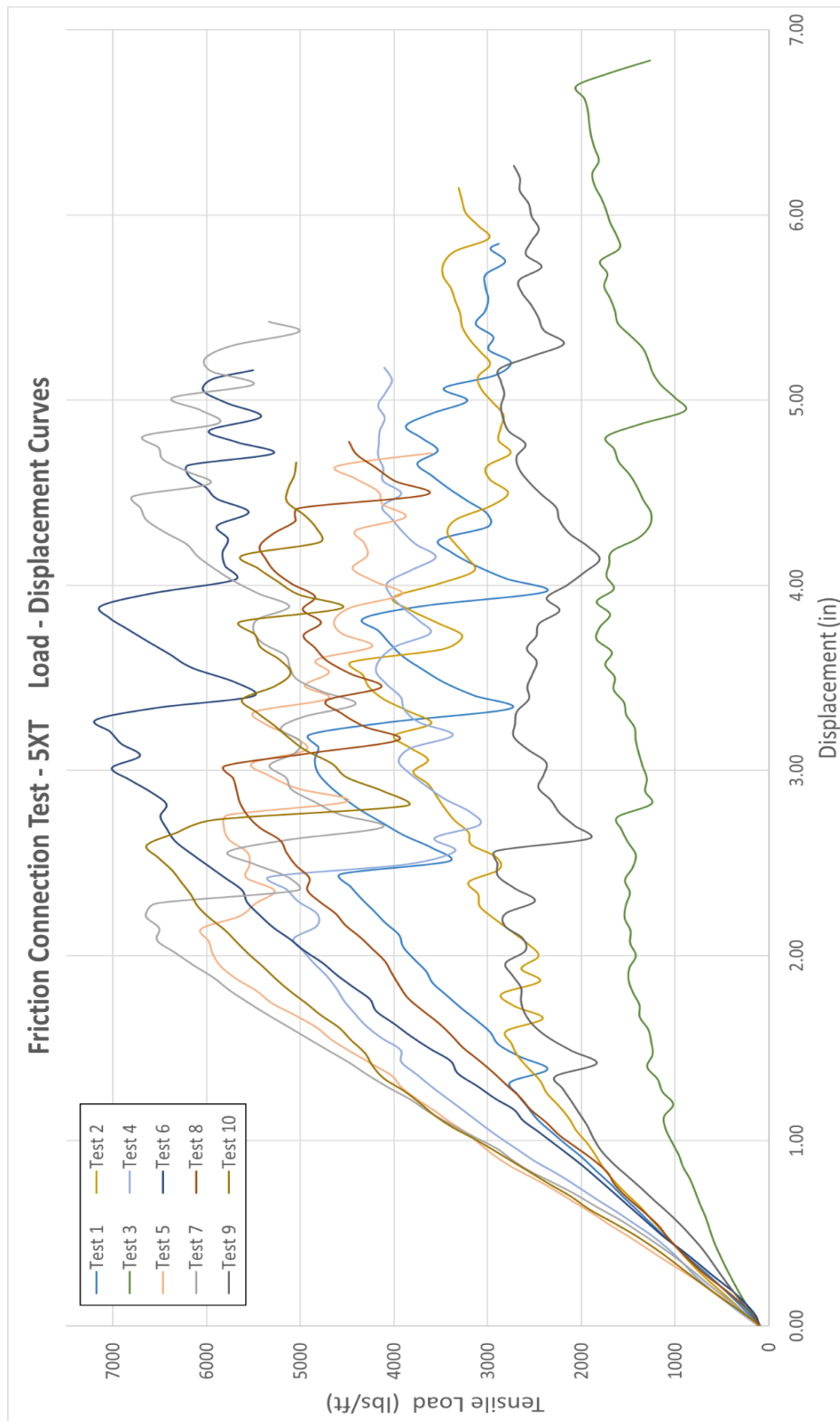

Figure 5 – Tension Force versus Horizontal Displacement - Miragrid 5XT

A summary of the peak tension load evaluated test results is shown in **Table 1**. A 2 in (51 mm) deflection limit was selected based upon industry standards and guidance.

Table 1 – Summary of Peak Friction Connection Strength Test Results

Test Number	Normal Load lb/ft	Normal Load kN/m	Peak Tension (2 in deflection) lb/ft	Peak Tension (2 in deflection) kN/m	Observed Failure
1	1,273	18.6	995	14.5	Geogrid Rupture
2	661	9.7	749	10.9	Geogrid Rupture
3	137	2.0	391	5.7	Geogrid Pullout
4	2,502	36.5	1,286	18.8	Geogrid Rupture
5	3,721	54.3	1,537	22.4	Geogrid Rupture
6	6,255	91.3	1,279	18.7	Geogrid Rupture
7	4,997	72.9	1,634	23.9	Geogrid Rupture
8	2,510	36.6	1,074	15.7	Geogrid Rupture
9	400	5.8	738	10.8	Geogrid Pullout
10	2,496	36.4	1,438	21.0	Geogrid Rupture

Peak connection strength loads were taken as the maximum measured tension load during each connection strength test. Peak loads plotted against normal loads for a 2 in (51 mm) deflection limit are shown in **Figure 6**.

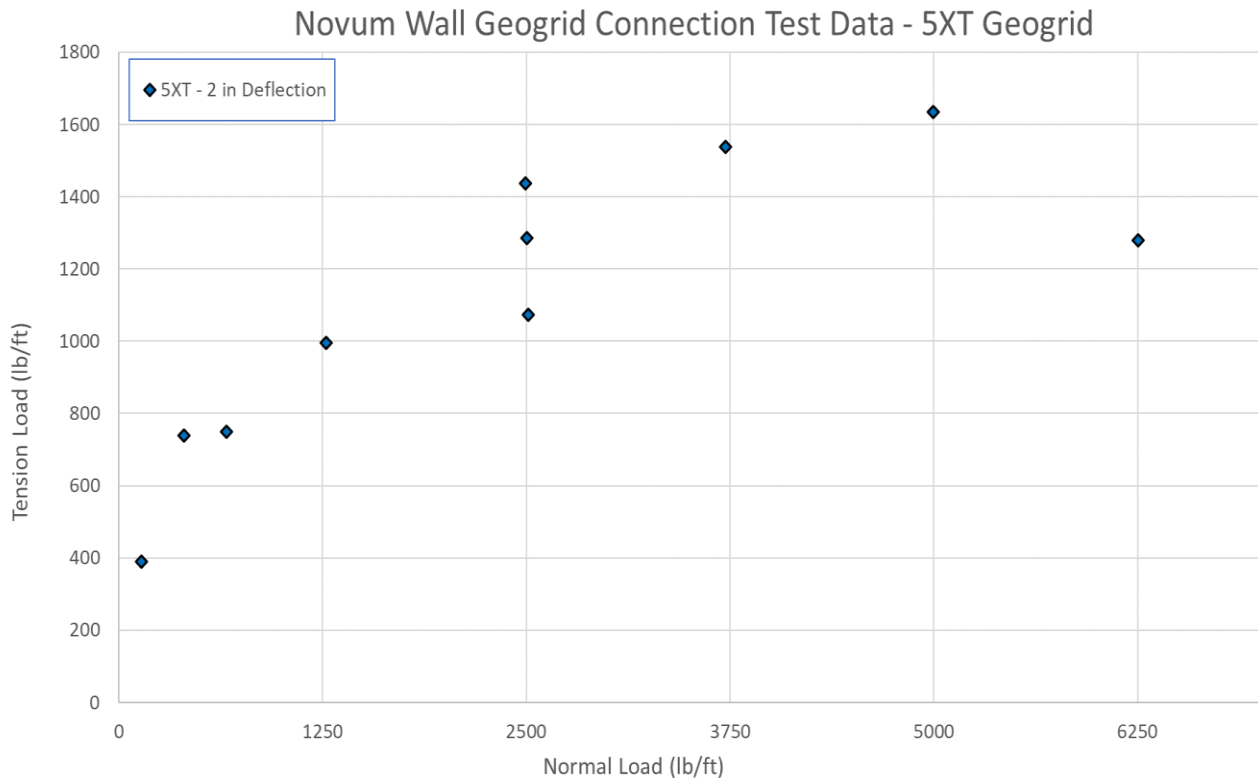

Figure 6 – Peak Connection Strength versus Normal Load

Additional tests were run at approximately 2,500 lb/ft (36.5 kN/m) normal load to check repeatability of the testing protocol. ASTM D6638 indicates a general range for repeatability of $\pm 10\%$ variation for each test from the mean of the tests. Upon review of the data, the test results were within a range of 15% of the mean of the tests.

The recommended friction connection strength envelope for use in design and analysis can be found in the design resources for Novum Wall®.

7.0 Closure

The data and conclusions contained herein should be used with care. The user should verify that project conditions are equivalent to laboratory conditions and should account for any variations.

This test data is accurate to the best of our knowledge and understanding. It is the responsibility of the end user to determine suitability for the intended use.

ASTER BRANDS



Laura B. Helbling, PE
Civil Engineering Consultant



Matthew A. Walz, PE
Testing Manager



Daniel J. Cerminaro, PE
Civil Engineering Manager



James R. Johnson, PE
Director of Innovation