



TASER 10 VR Controller User Guide



Rev: 25 Mar 2024

Axon Enterprise, Inc.
17800 N 85th St
Scottsdale, AZ 85255
USA

IMPORTANT SAFETY INSTRUCTIONS: Read all warnings and instructions, including the [Health and safety warnings](#) on page 1. Save these instructions. The most up-to-date warnings and instructions are available at www.axon.com.

▲, ▲ AXON, and TASER 10 are trademarks of Axon Enterprise, Inc., some of which are registered in the US and other countries. For more information, visit www.axon.com/legal.

Non-Axon trademarks are the property of their respective owners.

All rights reserved. ©2024 Axon Enterprise, Inc..

Contents

Introduction	1
Health and safety warnings	1
Controller features	2
Overview	2
Selector switch	2
Sidelight LEDs	3
Magazine	3
Timeout/sleep mode	4
Trigger	4
Holster tracking	5
USB port	5
App button	5
Pairing	5
Headset menu	5
Sleep mode	6
Battery packs	7
Storage	7
Removal	7
Installation	8
Charging	8
Known issues	8
Pair controller with HTC VIVE headset	9
Pair using headset settings	11
Pairing to a different headset	15
FAQs	18
TASER VRC	18
VIVE Focus 3 headset	19
Maintenance	24
Firmware updates	24
Care	24
TASER 10 VR Controller and water	24
Technical specifications	25
Customer service	26
Axon customer support	26
Product returns	26
Compliance	26

FCC compliance statement26
ISED Canada compliance statement27
RF exposure27

Introduction

The TASER 10 VR Controller (VRC) is a firmware-updatable LED controller used in conjunction with a virtual reality (VR) headset. Manufactured by Axon Enterprise, Inc., the TASER VRC is a dedicated training device designed to replicate the weight and feel of a traditional TASER 10 device.

Using a proprietary 2.4 GHz protocol, advanced IR LED Constellation tracking technology provides accurate three-dimensional physiology of the TASER VRC for inside-out tracking of objects within a virtual reality environment. It provides continuous TASER VRC-to-headset data exchange, letting you interact in a virtual world with the device mimicking the standard functionality of a duty TASER 10 device, such as arming, aiming, and deployment. This creates a true-to-life training experience without the challenges associated with TASER 10 being classified as a firearm.

Because it uses the same battery pack as a TASER 7 or duty TASER 10, the TASER VRC can apply agency settings from Axon Evidence. Like a duty TASER 10 device, when a battery is docked, agency configurations and operation are downloaded to memory within the battery and read by the TASER VRC when powered on.

Health and safety warnings

White TASER 10 VR Controllers are only for use in virtual reality (VR) training environments. They will neither accept nor fire probes like a duty TASER 10.

The most current safety and health warnings are available in a PDF located on our [Legal page](https://axon-2.cdn.prismic.io/axon-2/5bac101c-6f81-4c02-b737-b1be5eac6fce_Axon+VR+Warnings.pdf) at https://axon-2.cdn.prismic.io/axon-2/5bac101c-6f81-4c02-b737-b1be5eac6fce_Axon+VR+Warnings.pdf.

The safety and health warnings are to reduce the risk of any personal injury or property damage. **Read this manual and that document fully before using a VR headset.**

Controller features

Overview

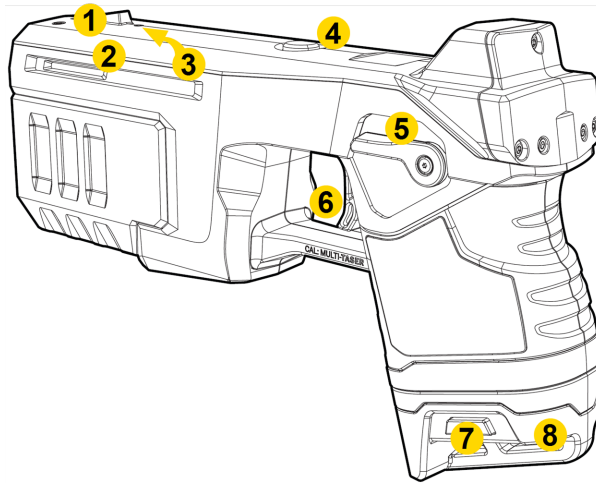

1. Front sight
2. Sidelight LED
3. Pairing LED
4. App button
5. Selector switch
6. Trigger
7. Battery release
8. Battery pack

Selector switch

Previous TASER devices had a two-position safety: On (Armed) and Off (Safe). The TASER 10 VR controller's (VRC) selector switch has different operating modes:

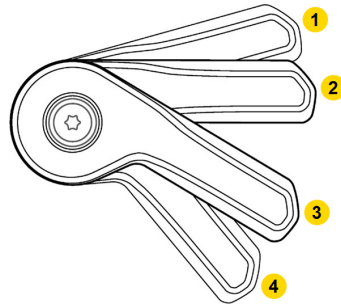

1. Tap up for re-energize (already deployed) or warning tone (not yet deployed)
2. On (Armed)
3. Off (Safe)
4. Hold down (not currently used for VR)







Don't block the Selector switch on one side of the TASER VRC while attempting to move it on the opposite side. This can break the switch and disable the controller.

Keep the TASER VRC in an Axon-approved, TASER VRC-specific holster when not in use.

Sidelight LEDs

Identical Sidelight LEDs on each side of the TASER VRC indicate current battery level (blinking) and trigger state, alternating between the two.

Once the controller recognizes the battery, the LEDs will display battery level and trigger presses as noted below.

State/Message	Sidelight LED Color
Battery >50%	 Green
Battery 15–50%	 Yellow
Battery 5–14%	 Orange
Battery 0–5%	 Red (rapid pulse)
Trigger press – Armed	 Purple
Trigger press – Safe	 Blue

Do not add stickers or markings to the top of the TASER VRC as these will affect internal sensors.

Magazine

Note TASER 10 VR Controller magazines are inert and will not accept live cartridges.



WARNING! VR CONTROLLER MAGAZINE USE

NEVER attempt to attach a live TASER 10 magazine (whether loaded or unloaded) to a TASER 10 VR Controller. ONLY USE WHITE magazines with a VR controller.

The TASER 10 VR Controller (VRC) has a removable magazine that can be left installed. Orient it properly before attempting to insert it.

To attach a TASER VRC magazine:

1. Set the selector switch to Off (Safe).
2. Hold the magazine from the bottom and align the upper guides on the magazine with the rails on the device.

- Slide the magazine approximately halfway toward the back of the device before pushing upward.

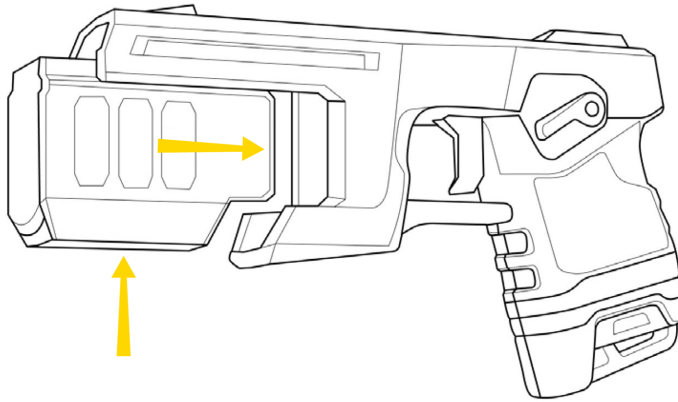

- Slide the magazine into the TASER VRC until you hear a click.
- Move the selector switch to On (Armed), then back to Off (Safe).

If the magazine does not "click" to the controller, remove it and confirm you're using a white VR magazine ONLY. The TASER 10 VR controller will still operate normally even without a magazine attached.

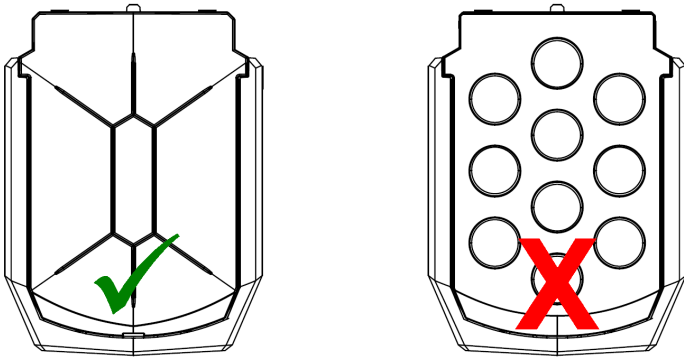

Use only VR magazines (left); do not use TASER 10 magazines (right).

Timeout/sleep mode

To conserve battery, the controller might enter sleep mode, indicated by sidelights and LEDs turning off. If this occurs while the device is armed, cycle the Selector switch from Off (Safe) to On (Armed) to reactivate it. See [Sleep mode](#) on page 6.

Trigger

The TASER 10 VR Controller trigger is a momentary electrical switch. The trigger is operational in VR only when the Selector switch is On (Armed).

Holster tracking

The TASER 10 VR Controller can track when it is holstered and unholstered in specific types of holsters. This feature works with Blackhawk, Safariland, and Blade-Tech holsters made specifically for VR controllers. An S.O. Tech holster works for both a duty TASER 10 and the TASER 10 VR controller.

USB port

The USB-C port on the front is an alternative method for updating firmware and directly pairing the controller to a VR headset. Do not use this function without specific instructions/directions from Axon Technical Support.



A TASER 10 VR Controller can **NOT** be recharged with this port.

App button

Use the round App button on top of the TASER VRC for pairing and accessing the headset menu.

Pairing

Press firmly (so it clicks) for about five seconds and release to enter pairing mode. The Pairing LED behind the front sight will illuminate to indicate status:

-  Blue – not paired
-  Blinking blue – trying to pair
-  Green – paired

For details on pairing, see [Pair controller with HTC VIVE headset](#) on page 9.

When pairing, don't hold the App button after the Pairing LED starts blinking; at ten seconds this will put the TASER VRC into [Sleep mode](#) (see page 6).

Headset menu

Use the App button to open the headset VR menu while using the HTC VIVE headset, allowing access to features such as pairing, Wi-Fi settings, starting a screen recording, exiting the application, or putting the controller in Sleep mode.

- Press the App button **once** to open the headset VR menu.
- Press the App button **twice** to enter or exit passthrough mode, which lets you see your surroundings in low-resolution black-and-white.

Sleep mode

There are multiple ways to put the TASER VRC in Sleep mode:

- Press the App button for ten seconds.
- Remove the headset for more than three minutes (adjustable in headset settings).
- Press the VIVE headset power button (at the back near the battery) to put both the headset and TASER VRC in Sleep mode.
- Move the TASER VRC out of range of the headset for more than 30 seconds.

Long-press the VIVE headset power button to turn the headset off, which will put the TASER VRC into sleep mode.

If the controller goes to sleep with the Selector switch On (Armed), wake up it up by toggling it down to Off (Safe) and back up to On (Armed).

Battery packs

Storage

Store battery packs in their original packaging, including the desiccant bag, until ready to be used. Do not store a battery pack anywhere the gold contacts on the top of the battery may touch metal objects; this may cause an electrical short between the contacts, draining the lithium energy cells and causing the pack to become dangerously hot.

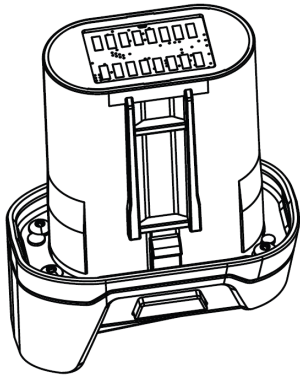

Removal

To remove the battery pack:

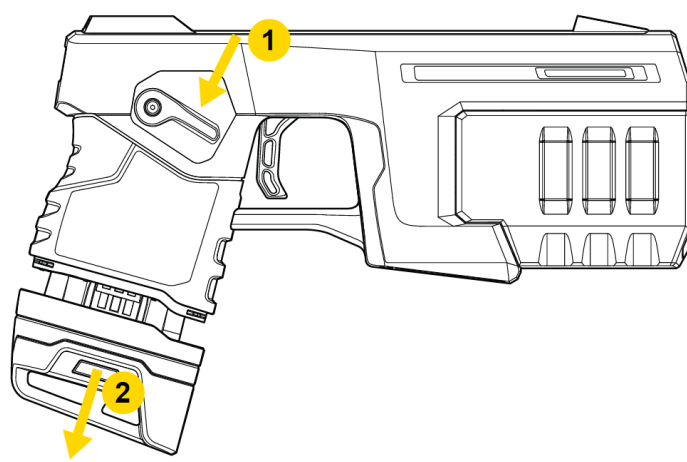

1. Set the Selector switch to Off (Safe).
2. Press the battery pack release buttons on each side of the battery pack and pull it from the controller.
3. Inspect the battery contacts to ensure they are free from dirt or other residue that may interrupt the battery connection to the controller.

Installation

1. Slide the battery in firmly.
2. When the battery pack seats properly, the release buttons will pop out from a recessed position with two audible clicks.
3. Pull on the bottom of the battery pack to confirm it is seated

The LED remains white  if the battery is not fully seated; see the Important statement in the next section.

Charging

Important A new TASER 10 battery must initially be charged for a **continuous 24 hours** in a network-connected and registered dock, during which the battery will be formatted and assigned an ID. Failure to provide this 24-hour charge for new batteries causes the TASER VRC (as well as duty TASER 10 devices) to act as if the battery is low even if it is fully charged.

Rechargeable battery pack (models TS1005 and TS1013)

Note Battery capacity will vary depending on temperature and environment.

When plugged into a battery dock, the rechargeable battery will begin charging and any agency settings will be imported (if configured). A battery pack requires approximately 4–6 hours to fully charge.

Wait until the battery pack is fully charged and agency settings have imported before removing it.

Refer to the [TASER 10 Quick Start Guide](#) and [TASER Weapons Dock Single-Bay Dataport Quick Start Guide](#) for more information.

Capacity check charging

The dock conducts a capacity check on a battery pack every 90 days. During a capacity check, it will discharge the battery fully and then recharge it. This ensures the battery maintains its health throughout its approximately 5-year useful life. A capacity check can take 6–8 hours.

Known issues

Once you use a battery in a TASER VRC and then dock the battery for charging, the LED on the dock will no longer turn green  like it normally does when the battery is fully charged. Nothing is wrong with the battery and this does not affect battery function. This behavior will be corrected in a future firmware update.

Pair controller with HTC VIVE headset

This article applies only to a white dedicated Virtual Reality controller that functions only in a VR environment.

The Pairing LED behind the front sight indicates the current pairing mode:



State/Message	Pairing LED Color
In pairing mode	■■■■ Blue, flashing
Paired	■ Green
Connecting, or pairing lost	■ Blue
Updating firmware (do not turn off)	■■■■ ■■■■ Blue and red flashing

Start the pairing process:

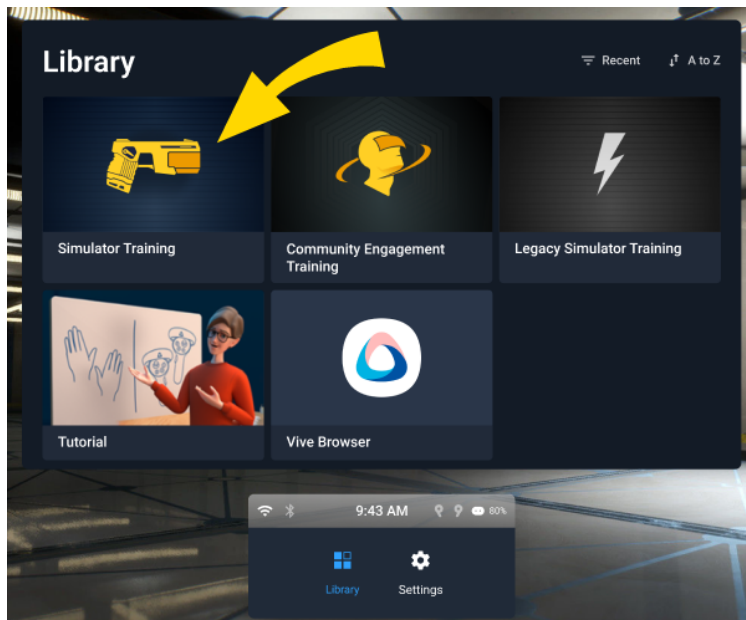
1. Turn the headset on by pressing the power button for about five seconds. It opens to the Library shown in the next step.
2. Use hand-tracking and pinch to select **Simulator Training** .



3. Use gaze to acknowledge the messages.
4. Move or cycle the Selector switch to On to wake up the TASER VRC.

5. Wait three seconds for internal systems to fully power on. The TASER VRC asks to begin pairing. The Pairing LED will be blue  (if green , it's already paired).



6. Press the App button firmly (so it clicks) until the Pairing LED starts flashing blue , or about three seconds.

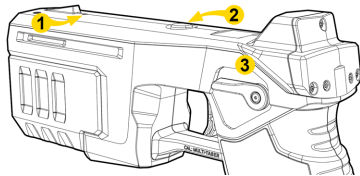

1. Pairing LED
2. App button
3. Selector switch up

- When the controller and headset are paired, a confirmation appears onscreen, the Pairing LED turns green , and Simulator Training launches.

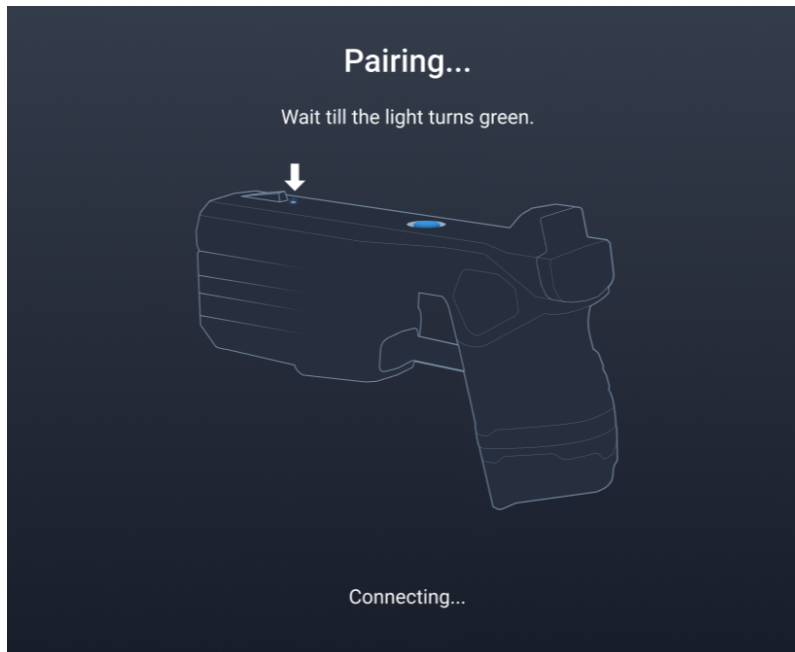

The TASER VRC will remain paired to the headset even if turned off or the battery is removed.

If pairing fails, the Pairing LED will remain blue ; cycle the Selector switch off/on, wait three seconds, and retry step 7.

Don't hold the App button for nine seconds or the TASER VRC will enter Sleep mode. It will also go to sleep after being idle 30 seconds to save battery (see [Sleep mode](#) on page 6).

Pair using headset settings

You can also pair using the headset settings menu.

- Turn the headset on by pressing the power button for about five seconds.
- In the headset library, use hand-tracking and pinch to select **Settings**.

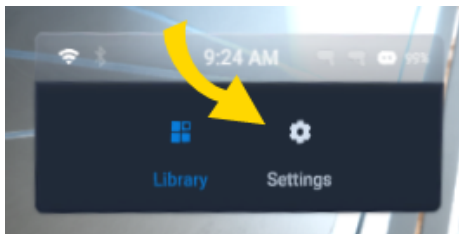

3. Select **Inputs**, then **Controllers**.

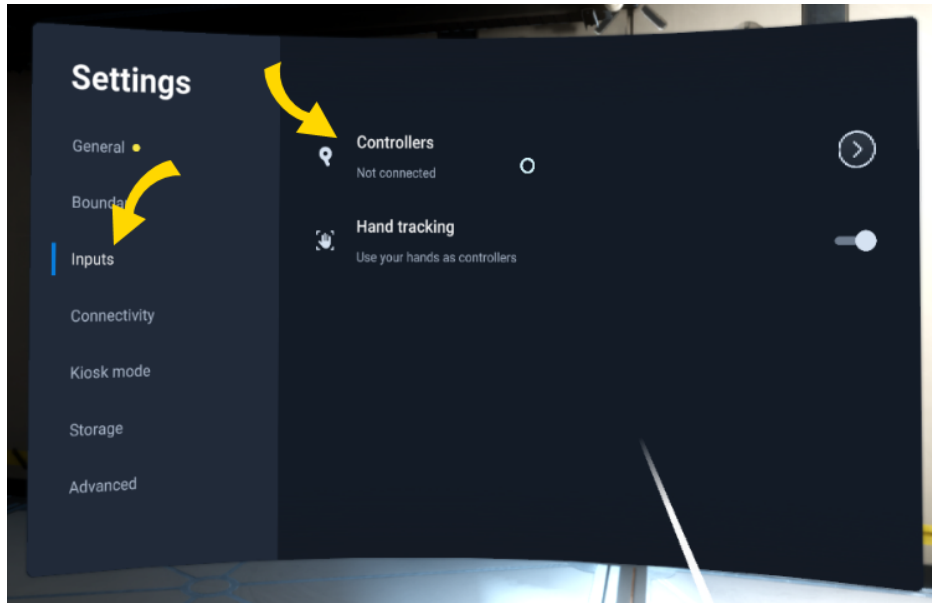

4. If any controllers are already paired to this headset, select **Continue** to unpair them.

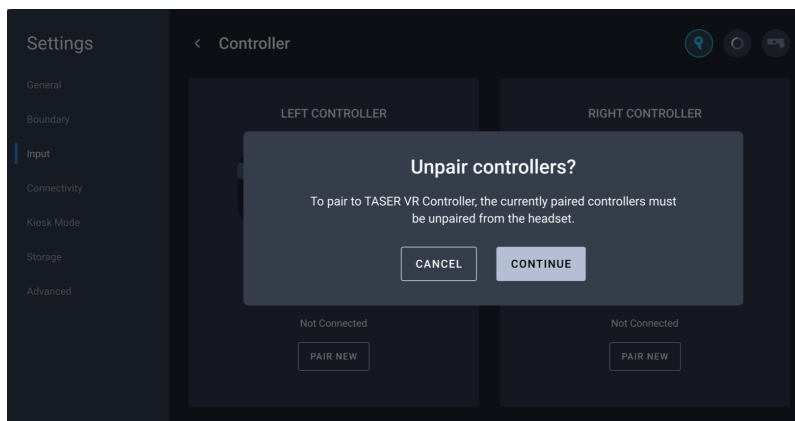

5. Move or cycle the selector switch to On to wake up the TASER VRC. The Pairing LED will be blue ■■■, (if green ■■■, it's already paired). Wait three seconds for internal systems to fully power on.

6. Press the App button firmly (so it clicks) until the Pairing LED starts flashing blue , or about three seconds.



7. Wait briefly for the TASER VRC to pair to the headset. When completed, the Pairing LED will turn green ...

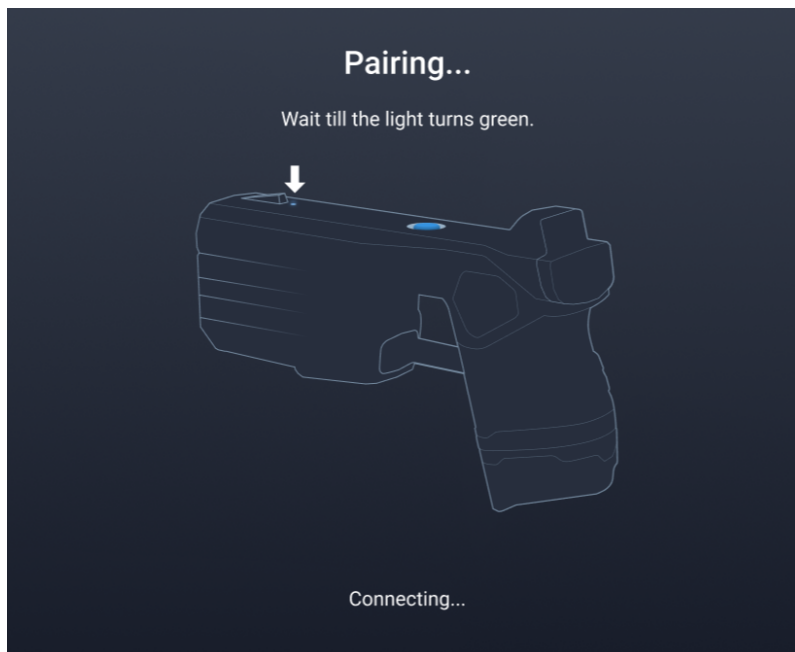

...the headset will confirm with "Connected"...



... and then it returns to the **Input** screen showing the connected controller and its firmware number.

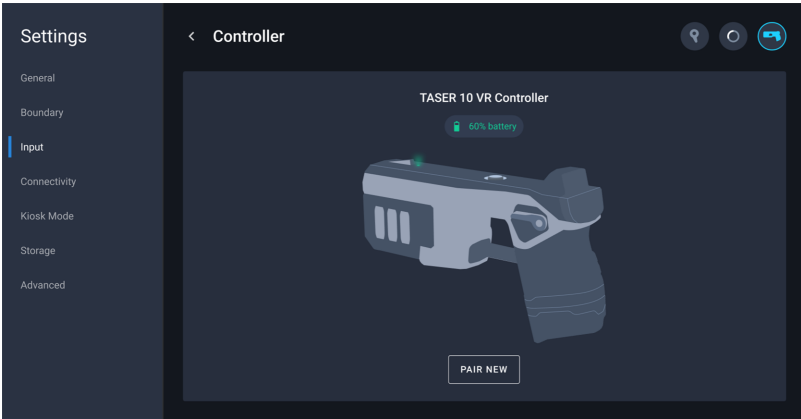

8. Select **Library** to exit the pairing screen.

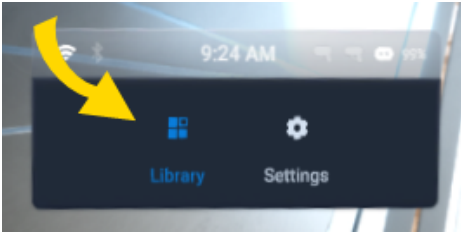

Pairing to a different headset

Pairing a TASER VRC to different headset is very similar to initial pairing, with just a little difference in the screens you'll see.

1. Turn the headset on by pressing the power button for about five seconds.
2. In the headset library, use hand-tracking and pinch to select **Settings**.

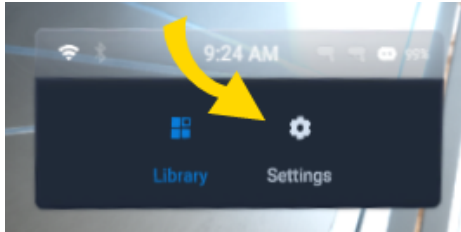

3. Select **Inputs**, then **Controllers**.

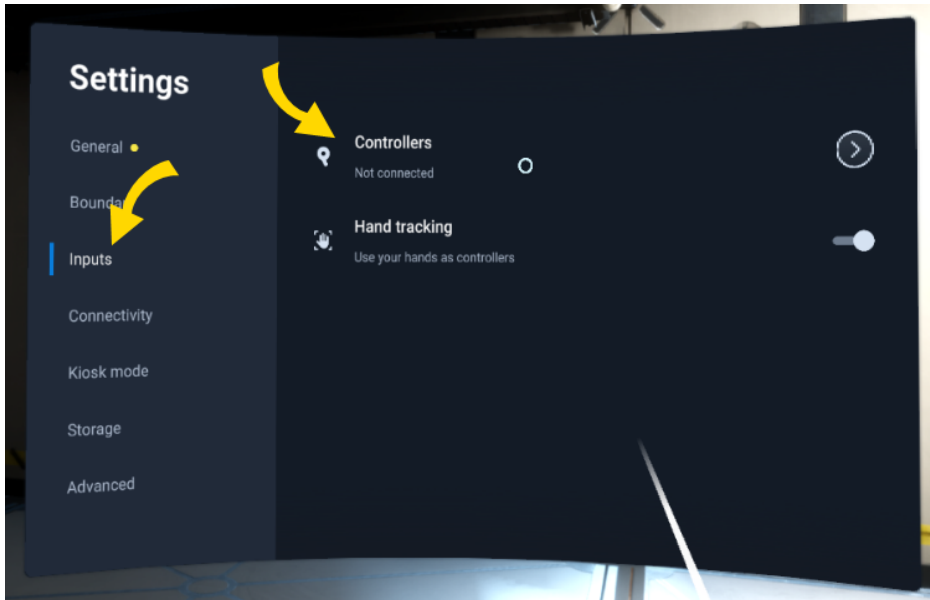

4. Because no TASER VRC is found, the headset requests to pair. Select **Pair New**.

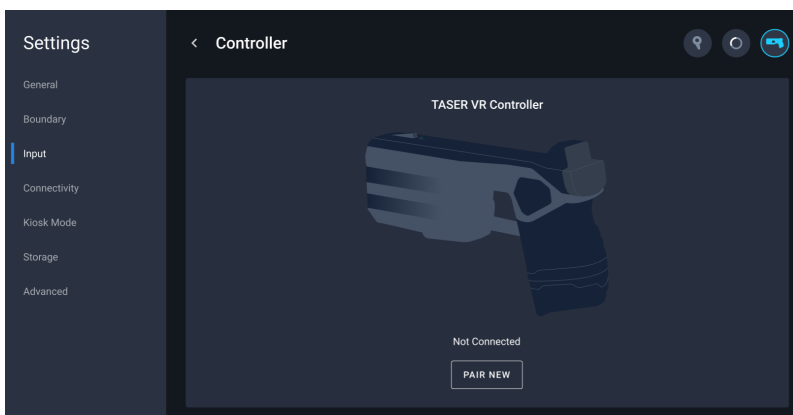

5. Move or cycle the selector switch to On to wake up the TASER VRC. The Pairing LED will be blue ■, (if green ■, it's already paired). Wait three seconds for internal systems to fully power on.
6. Press the App button firmly (so it clicks) until the Pairing LED starts flashing blue ■■■■, or about three seconds.

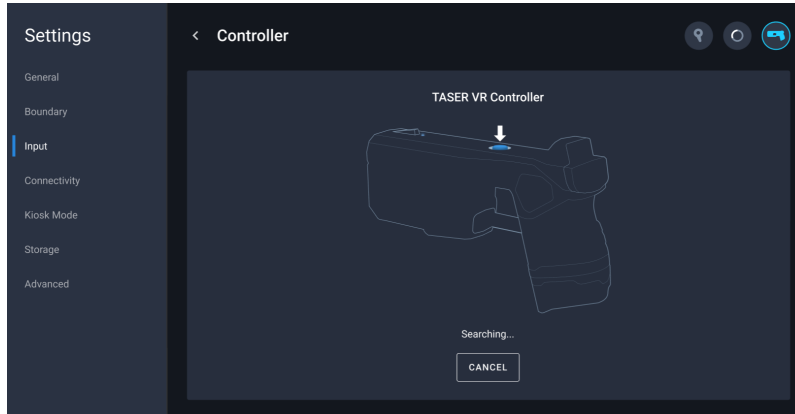

7. Wait briefly for the TASER VRC to pair to the headset. When completed, the Pairing LED will turn green ■...

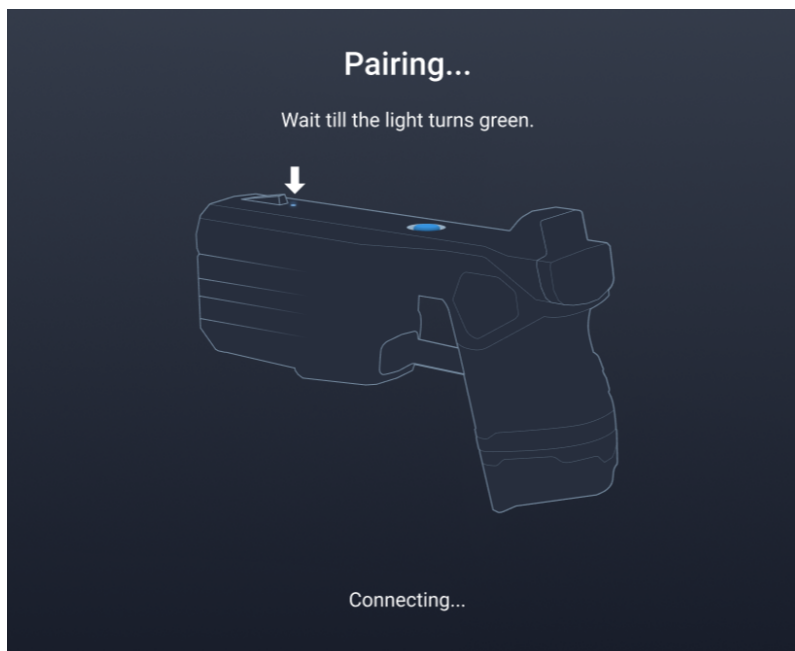

...and the headset returns to the **Input** screen showing the connected TASER VRC.

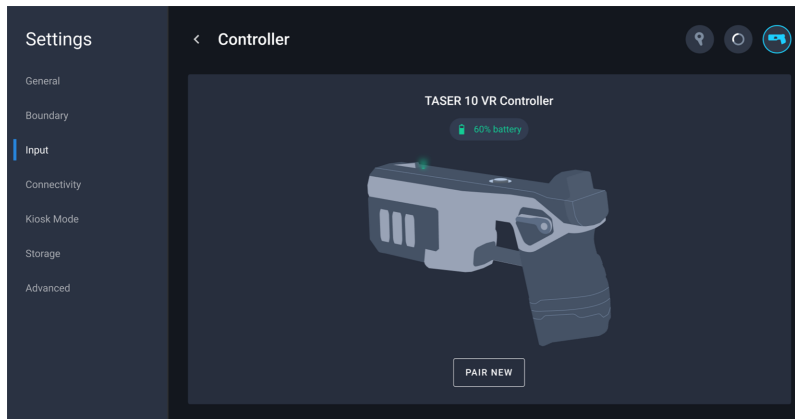

8. Select **Library** to exit the pairing screen.

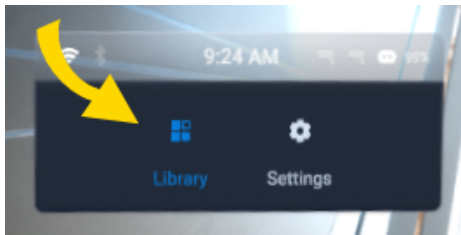

FAQs

TASER VRC

Why is my controller aim point drifting around while I'm in VR?

Ensure the side, top, and back are not covered by your hand, stickers, or any other obstruction. If battery level is low (red on the Pairing LED), switch to a fully charged battery.

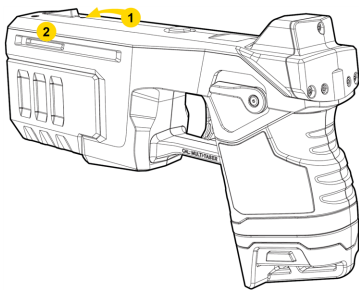

1. Pairing LED
2. Sidelight LED

Why when I insert a battery the Sidelight LEDs stays white and never displays battery strength?

The battery is not fully seated. See [Installation](#) on page 8.

What do all the Sidelight LED colors represent?

See [Sidelight LEDs](#) on page 2.

What is the USB port on the front for?

It is only for special use cases. See [USB port](#) on page 5.

VIVE Focus 3 headset

Warning Never factory-reset your headset. A factory-reset headset must be returned to Axon to be re-provisioned.

How do I check or update the headset firmware?

Your VIVE VR headset will periodically check for the latest features or enhancements. If you'd like to check manually:

1. Ensure the headset has at least 30% battery charge (two LEDs).
2. From the Library, select **Settings**.

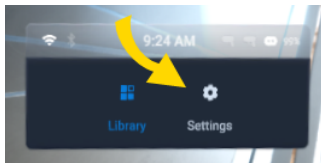

3. Select **General**. Scroll the window to **System update** at the bottom. The current firmware version is listed there. If not, select **About**.

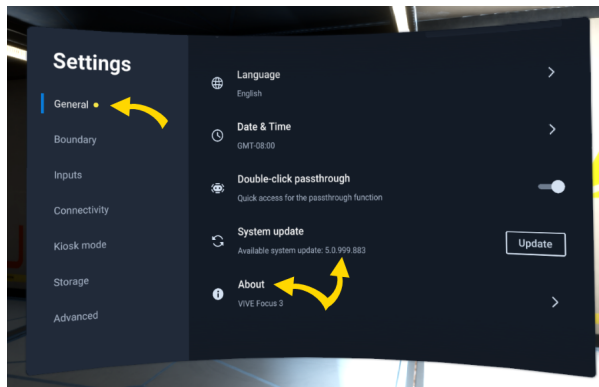

4. Verify the firmware number beside **System version**.

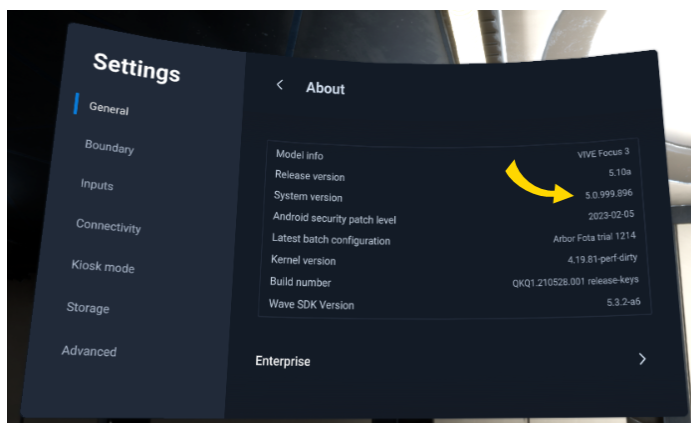

5. If the firmware needs to be updated, return to the About screen and select **Check now** and then **Update**, or just **Update**.

Some updates may require restarting your headset.

Why can't I see the controller as an input in HTC settings?

1. Turn the headset on.
2. For HTC VIVE Focus 3 headsets, look in settings to ensure the operating system version (ROM) is at least 5.0.999.883 (see the first FAQ for screens).

If you updated your headset ROM and still can't see the VR Controller input in HTC Settings:

1. Ensure your headset has at least 30% battery (two LEDs).
2. Go to **Settings > General > About > Enterprise**.
3. Select **Reload**.

You have successfully reloaded the Batch Configuration if your background changes from the desert environment to the Axon spaceship theme. The controller should now appear in HTC settings as an input. If it still doesn't appear, contact Axon technical support for assistance.

Why can't I see the library? All I see is passthrough mode.

If you see passthrough mode all the time, you are outside the boundaries already established on the headset. Look around to find the boundary outlined on the floor, or as a virtual wall, and move inside it.

To reset the boundary, in the headset go to **Settings > Boundary**.

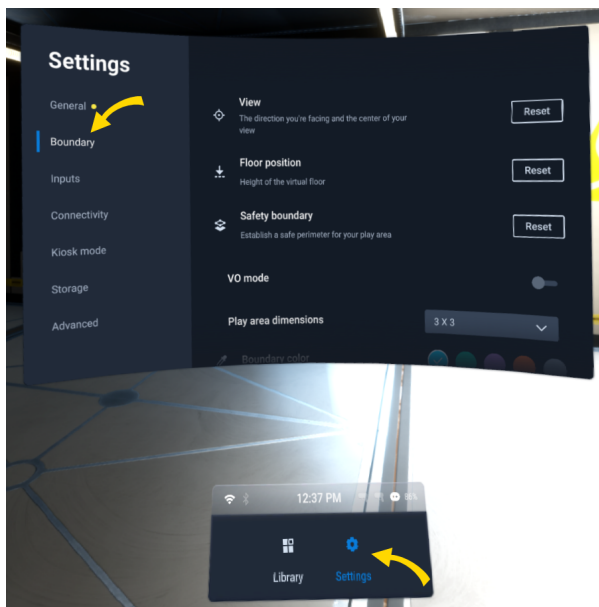

Why I can't use hand-tracking and pinch to select things in Axon apps?

Making selections in Axon apps is actually easier. Simply look at the item you'd like to select and a round countdown timer appears. When it gets to zero after about a second, it makes the selection without you having to lift a finger.

Why does my headset forget the play boundary?

A saved boundary may be lost if there is a significant change in the environment since the original boundary was set up. The following factors can influence the boundary:

Lighting

- Changes in light level from windows, such as day to night.
- Changes in light direction, such as light coming from a different side.
- Changes in light level from artificial sources, such as turning lights on and off.

Decor

- Changes to physical surroundings, such as furniture.
- Changes to appearance, such as decorations.

People

- Many people moving around the training space.

Why can't I connect to my secure Wi-Fi network?

Your Wi-Fi may require you to sign in first on a webpage.

1. In the headset, go to **Settings > Network > Wi-Fi**.
2. If the message "Connected, not online" appears next to the network name, this indicates it requires a sign-in via a web portal.
3. From the **Library**, select **Firefox** to open a web page.
4. If the network sign-in portal does not appear, open any other page, such as axon.com, google.com, or msn.com to trigger the sign-in portal.
5. Sign in with your credentials.
6. Try opening another webpage. If the content loads, the headset is now online.

Why are the Axon VR apps not in my library?

1. Ensure you've completed all steps in [Focus 3: Headset setup](#).
2. Go to **Settings** > **Network** > **Wi-Fi**. If you see "Connected, not online", your Wi-Fi may require a webpage sign-in; see the prior FAQ item on Wi-Fi.
3. From the **Library**, select **Firefox** and open a webpage like axon.com to verify the network connection is active.
4. If still not connected, try temporarily connecting to a mobile hotspot Wi-Fi. If you can now browse the web, your agency Wi-Fi is not letting you connect. Contact your IT department for assistance.
5. Go to **Settings** > **General** > **System Update**.
6. If an update is available, select to install. Restart the headset if instructed. Return to **System Update**. Repeat this step until no further updates are available.
7. Turn the headset off for 10 minutes, then turn it back on. Axon's apps should now be present in the library (see the first screen in the [Pairing](#) section on page 9 for a sample). If not, record the Headset system version and serial number and contact Axon Support for further assistance.

Why is my headset stuck at the VIVE logo screen?

A black screen with a loading white VIVE logo typically occurs when using a headset in a space with poor lighting and/or too few indistinct objects or features. The headset is trying to create a map of the current space to create a boundary, but if there are too few points to reference, it may get stuck on this loading screen. Turn the headset off, move to a location with better lighting and turn the headset back on.

The headset may also appear stuck at the loading screen if it is looking for a previously saved boundary and orienting itself in the environment. The orientation process may take a couple minutes, depending on connection speeds.

How do I find my headset's serial number?

You'll find the headset serial number in two places:

1. From the headset library, go to **Settings** > **General** > **About** > **Headset status**.
2. Or, pull off the magnetic face shield and find the very-small serial number on the label next to the left lens.

How do I change the menu language?

1. If needed, exit to the main lobby.
2. Select **Settings**.

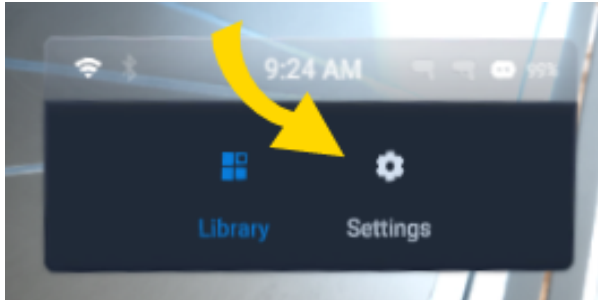

3. On the **General** tab, select **Language**.
4. Select your language.
5. Select **Library** to exit.

This affects the language of the headset menus, not the apps themselves. The headset may provide more language options than are available for the onboard apps.

Maintenance

Firmware updates

The TASER 10 VR Controller (VRC) internal firmware provides functionality for all aspects of the TASER VRC.

Available firmware updates are applied wirelessly to the TASER VRC through the VR headset after a prompt and approval from the user. The controller will be unavailable until the Pairing LED is no longer flashing blue ■■■■ and red ■■■■, indicating the update is complete.

Care

The TASER VRC is a sensitive piece of electronic equipment and should be handled with care. Avoid dropping the TASER VRC and cease use if it becomes cracked.

Each agency should establish a maintenance and handling program that includes:

1. Check the battery pack. If using a rechargeable battery (TS1005 or TS1013), recharge it when the battery percentage drops below 30%.
2. Secure the TASER VRC in a protective holster when not in use.
3. Update the TASER VRC's firmware when it is available.

TASER 10 VR Controller and water



Do not immerse the TASER 10 VR Controller in any liquids. Avoid exposing the TASER 10 VR Controller to excessive moisture.

The TASER 10 VR Controller is not a weatherproof device. Do not immerse the TASER VRC in water or any other liquid. If a TASER VRC has been submerged in liquid or exposed to a significant amount of moisture, immediately remove the battery pack, remove the controller from service, and contact Axon.

Technical specifications

The TASER 10 VR Controller is a virtual reality controller and can only be used with virtual reality applications. No components can be used as a weapon or converted into a weapon. Buttons are used for communicating trigger action and for Bluetooth Low Energy (BLE) pairing to a compatible virtual reality headset.

Parameter	Result
Length	6 in. (152.4 mm)
Height	4 in. (101.6 mm)
Width	2 in. (50.8 mm)
Weight	0.64 lb (0.29 kg)
Trigger type	Electronic (binary non-adjustable)
Construction	Black and white polymer
LEDs	<p>Pairing LED – Single LED behind the front sight for pairing status indications</p> <p>Sidelight LEDs – Single LED on both sides to indicate battery status and trigger actions</p> <p>Tracking LED – Eight Infrared LEDs on the controller allow the separate headset's camera to track the location of the controller within 3D space</p>
Comms	2.4 GHz proprietary Bluetooth channel
Power type	Separate 2-cell lithium-ion battery pack (not included)
Battery voltage	7.4 V nominal
Operating range	32–104 °F (0–40 °C)
Battery charging method	Separate docking station

Actual measurements on products may vary due to items outside Axon's control. Product specifications may change without notice. The actual product may vary from picture, image, or graphic. Refer to current Axon published product specifications for specified limits and test conditions. Read the manual and all product literature.

For more information, see current TASER 10 device/product specification sheets, training materials, product manuals, and website at www.axon.com. Axon Enterprise, Inc. reserves the right to change or modify this document without notice.

Customer service

Axon customer support

Find additional guides and troubleshooting at my.axon.com/s/axon-vr-training or contact customer support at:

- US and Canada – 800-978-2737
- UK – +44 01327 709 666
- AU – 1-800-512-069
- NZ – 1-800-005-161

Visit www.axon.com/support for other international telephone numbers.

Product returns

To return a TASER 10 VR Controller for service, follow the procedures at www.axon.com.

Compliance

A TASER 10 VR Controller system transmission is in the frequency ranges of 2402–2480 MHz.

Changes or modifications to the equipment not expressly approved by the manufacturer could void the product warranty and the user's authority to operate the equipment.

FCC compliance statement

Your wireless device is a radio transmitter and receiver. It is designed and manufactured not to exceed the emission limits for exposure to radio frequency (RF) energy set by the Federal Communications Commission (FCC) of the U.S. Government. These limits are part of comprehensive guidelines and establish permitted levels of RF energy for the general population. The guidelines are based on standards that were developed by independent scientific organizations through periodic and thorough evaluation of scientific studies. The standards include a substantial safety margin designed to assure the safety of all persons, regardless of age and health. Before a device model is available for sale to the public, it must be tested and certified to the FCC that it does not exceed the limit established by the government-adopted requirement for safe exposure. This equipment has been tested and found to comply with the limits for a Class B digital device, pursuant to part 15 of the FCC Rules. These limits are designed to provide reasonable protection against harmful interference in a residential installation. This equipment generates, uses and

can radiate radio frequency energy and, if not installed and used in accordance with the instructions, may cause harmful interference to radio communications. However, there is no guarantee that interference will not occur in a particular installation. If this equipment does cause harmful interference to radio or television reception, which can be determined by turning the equipment off and on, the user is encouraged to try to correct the interference by one or more of the following measures:

- Reorient or relocate the receiving antenna.
- Increase the separation between the equipment and receiver.
- Connect the equipment into an outlet on a circuit different from that to which the receiver is connected.
- Consult Axon Technical Support for help.

This device complies with part 15 of the FCC Rules. Operation is subject to the following two conditions: (1) This device may not cause harmful interference, and (2) this device must accept any interference received, including interference that may cause undesired operation.

ISED Canada compliance statement

This device complies with Industry Canada licence-exempt RSS standard(s). Operation is subject to the following two conditions: (1) this device may not cause interference, and (2) this device must accept any interference, including interference that may cause undesired operation of the device.

Le présent appareil est conforme aux CNR d'Industrie Canada applicables aux appareils radio exempts de licence. L'exploitation est autorisée aux deux conditions suivantes : (1) l'appareil ne doit pas produire de brouillage, et (2) l'utilisateur de l'appareil doit accepter tout brouillage radioélectrique subi, même si le brouillage est susceptible d'en compromettre le fonctionnement.

RF exposure

The equipment complies with FCC/ISED radiation exposure limits set forth for an uncontrolled environment. The metal is assembled and has a minimum distance of 27.86 mm between the device, the antennas, and the user's body.

L'équipement est conforme aux limites d'exposition aux rayonnements FCC/ISED établies pour un environnement non contrôlé. Le métal est assemblé et présente une distance minimale de 27.86 mm entre l'appareil, les antennes, et le corps de l'utilisateur.

FCC responsible party

Name: Axon Enterprise, Inc.

Address: 17800 N 85th St, Scottsdale Arizona 85255, USA

Telephone number: 1-800-978-2737

www.axon.com