



WARNING

Energy Weapon

- Can temporarily incapacitate target.
- Can cause death or serious injury.
- Follow warnings, instructions and all laws.
- Comply with current training materials and requirements.
- See www.axon.com

Step 1. Confirm the Energy Weapon Is Ready for Use

Check with your TASER Program Coordinator to be sure firmware is version 1.5.39 or higher, the energy weapon has the correct set-up for your agency, the battery is fully charged, and that the weapon and magazine packs have been properly assigned to you.

Step 2. Load the Magazine with Cartridges

TASER 10 magazines are available in a variety of different types and colors. The color identifies the intended use for the magazines. **Only black magazines are intended for duty use.** See the *TASER 10 Energy Weapon User Manual* for information about other magazines and cartridges.

Always point the front of the magazine in a safe direction. Never place your hands, fingers, or other body parts in front of the magazine while it is loaded in the TASER 10 energy weapon.

- 1 Confirm the magazine has a part number of 101755 by checking the top of the magazine.
- 2 Slide the cartridge with the front facing away from you, front-first into the back of the chamber until the cartridge is fully seated. Repeat until all cartridges are loaded.
- 3 Ensure the cartridges are seated evenly in the magazine. Look at the magazine from the side to confirm proper cartridge placement.

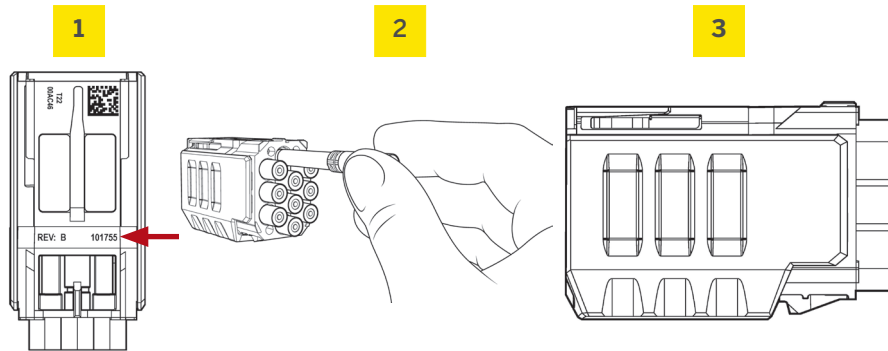

Step 3. Load the Magazine into the Weapon

- 1 While gripping the magazine from the bottom, align the guides on the magazine with the rails on the weapon. Slide the magazine approximately halfway towards the back of the weapon before pushing upward.

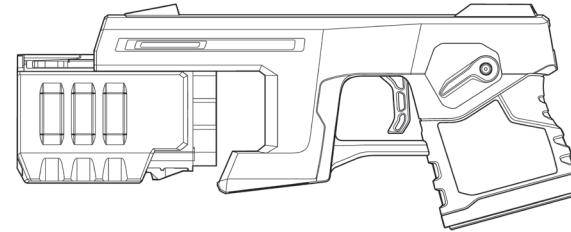

- 2 Push the magazine into the magazine well until you hear an audible "click."

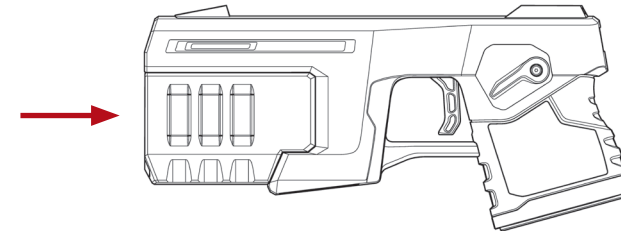

- 3 Visually inspect to ensure the magazine is properly aligned and fully seated into the magazine well of the weapon, and there is no gap between the magazine and weapon. Gently tug on the magazine to ensure it is fully seated.

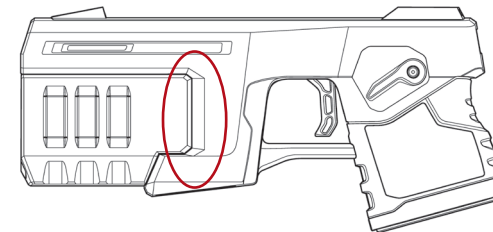

TASER 10

DUTY MAGAZINE INSTALLATION GUIDE



WARNING

Energy Weapon

- Can temporarily incapacitate target.
- Can cause death or serious injury.
- Follow warnings, instructions and all laws.
- Comply with current training materials and requirements.
- See www.axon.com.

Step 4. Insert the Battery

Insert the battery pack into the weapon. Press firmly until you hear the latch on both sides of the battery pack “click.”

When a new battery pack is inserted into the handle it will automatically synchronize the weapon’s logs to the battery pack and may update the energy weapon firmware. **Do not remove the battery pack or perform any other action with the energy weapon until the icon disappears from the CID** (this may take several minutes).

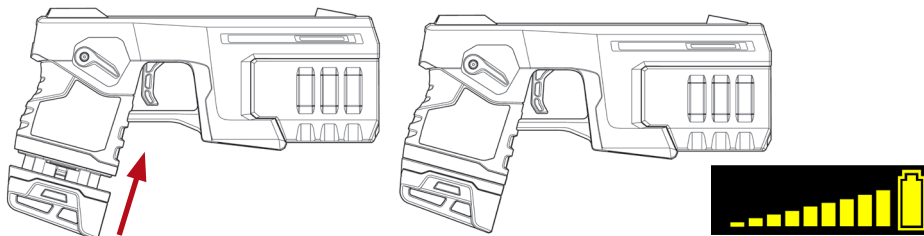

Step 5. Turn the Weapon On and Off

After loading the weapon:

- 1 Point the weapon in a safe direction.
- 2 Move the safety to the up (ARMED) position.
- 3 Confirm the CID displays all the cartridges.
- 4 Move the selector switch to the down (SAFE) position.
- 5 Conduct a function test. See the *TASER 10 Energy Weapon User Manual* for more information.

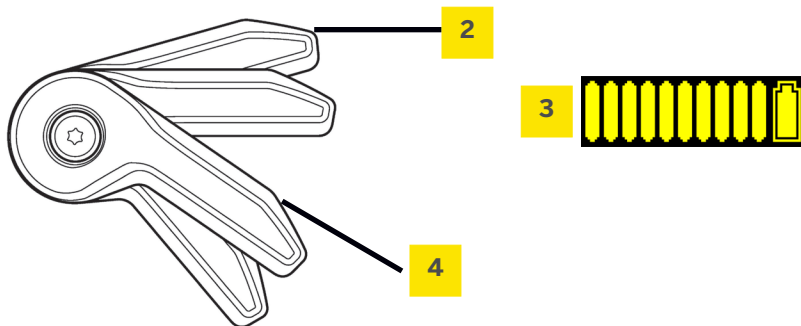

Step 6. Removing the Magazine

- 1 Point the weapon in a safe direction.
- 2 Ensure the safety is in the down (SAFE) position.
Do not put your hands in front of the magazine.
- 3 Pull the magazine forward to remove it from the weapon.

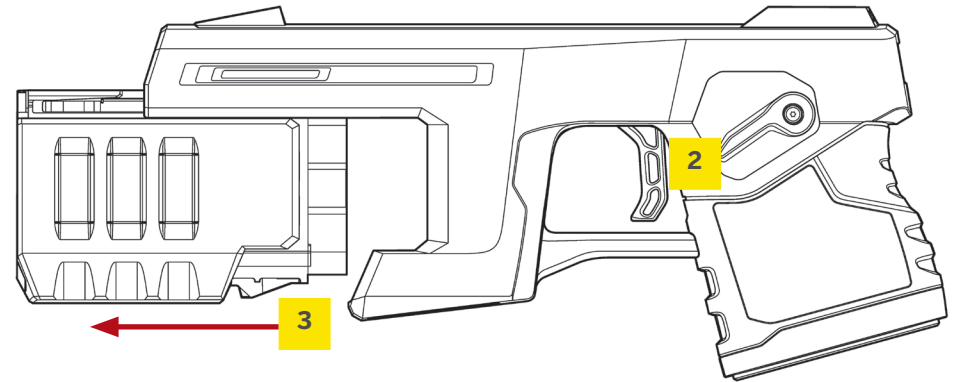

Best Practices for Optimal Use

- **Proper seating:** Always verify the magazine is fully seated in the weapon by listening for the audible click before operating the TASER 10 energy weapon to prevent cartridge read issues.
- **Use consistent pressure:** Avoid excessive force when inserting or removing cartridges and magazines; instead, use steady, consistent pressure to align components smoothly.
- **Routine checks:** Regularly inspect the magazine for wear or debris that could interfere with seating and function.
- **Updated Firmware:** Ensure the firmware version is up to date with version 1.5.39 higher.

If you need assistance, please visit www.axon.com or contact technical support at: US: 1-800-978-2737; Australia +1 800-051-2069; other international +1 480-463-2170

▲, ▲ AXON, Axon, TASER 10, and Ⓞ are trademarks of Axon Enterprise, Inc., some of which are registered in the US and other countries. For more information visit www.axon.com/legal. All rights reserved.
©2025 Axon Enterprise, Inc.