



TASER Weapons Dock Installation Manual

English



IMPORTANT SAFETY INSTRUCTIONS

Read all warnings and instructions. Save these instructions.

The most up-to-date warnings and instructions are available at www.axon.com

MMU0073 Rev: L

October 2025



Contents

- 1 Chapter 1: Introduction to the TASER Weapons Dock**
- 1 TASER Weapons Dock Modules
- 2 Additional Materials
- 3 Chapter 2: Agency Network Configuration**
- 3 Background
- 3 Network Requirements
- 3 Firewall Configuration
- 4 IP Address Configuration
- 5 Chapter 3: TASER Weapons Dock Installation**
- 5 Introduction
- 13 Safety Instructions
- 13 Tools and Materials
- 13 Dimensions
- 13 Chapter 4: Wall Mounting a TASER Weapons Dock**
- 14 Dimensions for a TASER Weapons Dock Multi-Bay with TASER Battery Packs in a Mounting Bracket
- 17 Removing the Locking Adapters
- 18 Chapter 5: Attaching the Desk Plate**
- 18 Introduction
- 18 Tools and Materials
- 21 Chapter 6: Troubleshooting the TASER Weapons Dock**
- 22 Status Lights
- 23 Chapter 7: Network Troubleshooting**
- 23 Status Page Errors
- 24 Dock Registration Error Codes
- 25 Chapter 8: Additional Items**
- 25 Radio Waves
- 25 Declaration of Conformity
- 26 Compliance Marks

Chapter 1: Introduction to the TASER Weapons Dock

The TASER Weapons Dock uploads data from TASER 7 and TASER 10 battery packs to the Axon Evidence (Evidence.com) cloud computing website. While information is transferred securely to your organization's account, the dock also recharges the batteries (if the batteries are rechargeable). TASER 7 and TASER 10 battery packs work with the same docking modules.

TASER Weapons Dock Modules

A dock has two major parts. One is the core module, which connects to the Internet and transfers information to Axon Evidence (Evidence.com) services. This is the standard Axon core module that is used with Axon camera bays. The other is the multi-bay, which accepts up to six battery packs.

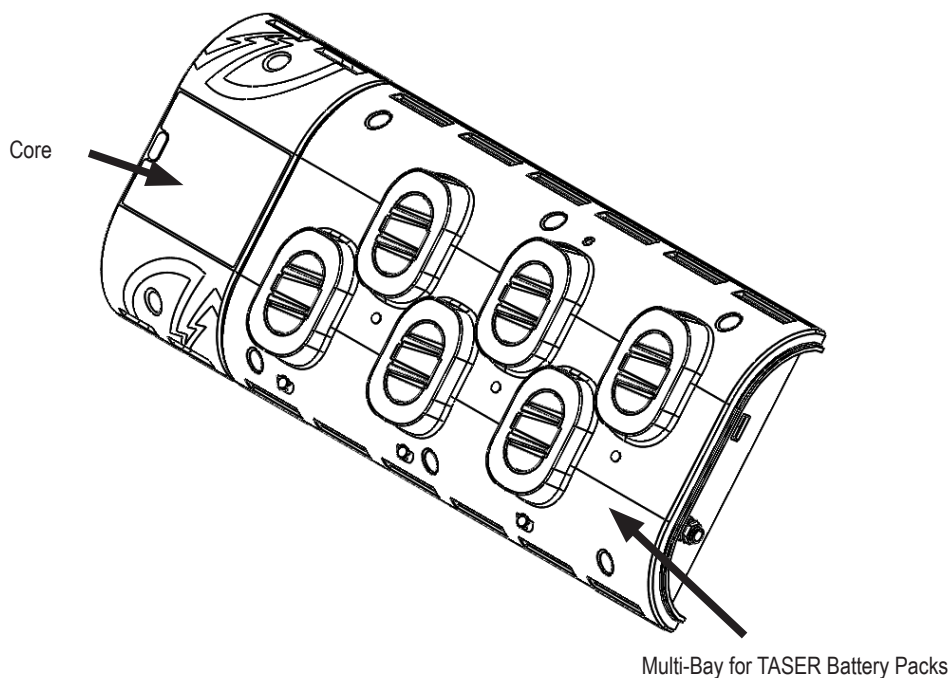

An additional bay, called the single-bay, is available. The single-bay can be used with a computer via a USB cable and Evidence Sync software. Or, it can be attached to an Axon Dock core module. This manual provides instructions for the dock and core combination.

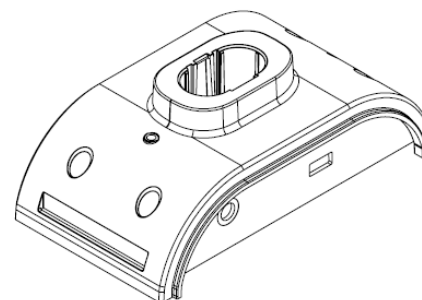

Single-Bay for Non-Rechargeable Battery Packs

A bridge adapter is used to attach the core to a bay.

Be careful when removing a bridge adapter from a bay, as damage may occur if the bridge adapter is removed unevenly from the bay. Bridge adapters must be pulled straight out and not angled when removed.

A locking adapter is used to help fasten a core and bays together.

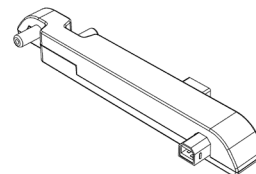
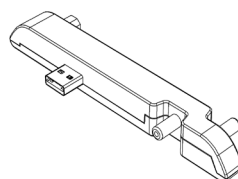
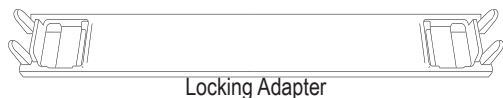

Additional Materials

The package containing the TASER Dock also contains two Ethernet cables and an external power supply with an AC power cable.

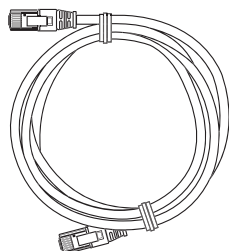
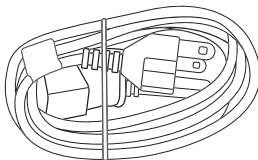
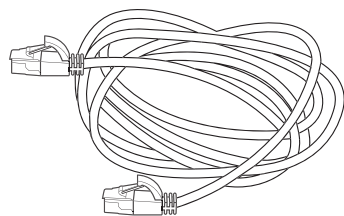

Ethernet Cables

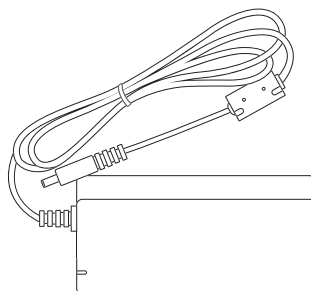

Power Supply and Cable

Chapter 2: Agency Network Configuration

Background

TASER 7 and TASER 10 energy weapons record data when they are used. When the energy weapon user(s) finish their shifts, the TASER battery pack is docked into the TASER Weapons Dock. The dock uploads the content securely via 256-bit SSL to Axon Evidence (Evidence.com) services. Using an agency account on the Axon Evidence (Evidence.com) website, TASER users can review the content, share evidence with other personnel in the organization, and download data.

Network Requirements

To get the dock up and running, you may need some assistance from your IT department.

TASER Weapons Docks generate Internet Control Message Protocol (ICMP) packets to the DNS and gateway every 3–7 minutes. This is done to update the status of the gateway/DNS on the status page. Your network must allow for the transmission of these packets.

Although the docks are hardened against external intrusion, it is **STRONGLY** recommended for maximum security that industry standard security policies be followed by placing the dock behind your agency's firewall.

DO NOT place the dock directly on the Internet. The dock must be connected behind a firewall or secure network.

Firewall Configuration

The dock and TASER devices do not require any incoming data ports for regular operation. All dock communications are outbound. All data files are transmitted securely using HTTPS (SSL) and 256-bit AES encryption. For proper operation, the dock requires the following outbound firewall ports:

1. Port 443 (TCP) opened for outgoing traffic to your agency's domain (e.g., youragency.evidence.com). This is used by the dock to send data files to Axon Evidence (Evidence.com) using the HTTPS protocol.
2. Port 53 (UDP) opened for access to DNS, if your network uses external (internet) DNS servers. When using external DNS servers this is necessary for the dock to locate the servers for your Axon Evidence (Evidence.com) account.
3. Port 80 (TCP) for time synchronization.

Accessing Dock UI via HTTP:80 will always redirect to HTTPS:443 for a secure connection.

If the **Accept only SSL Requests** option on Admin page of Dock UI is unchecked, users can access Dock UI using HTTP:8080. If it is checked, users will not be able to access Dock UI via HTTP:8080.

Once registered to your agency, the dock uses one of two methods to synchronize the clocks on the TASER devices:

1. HTTP over port 80 (TCP) to synchronize time from youragency.evidence.com;
2. HTTPS over port 443 (TCP) to synchronize time from youragency.evidence.com.

The dock requires only one of the above methods to be available. By default the dock uses Method #1 and requires port 80 be enabled for outbound access on the firewall. Method #2 is the most secure, requiring no additional ports to be opened in a firewall. However, in certain rare circumstances the HTTPS connection can fail if the clock on the dock is too far out of sync with the actual time. To enable option two, you must select the **Require SSL For Initial Time Check** checkbox on the **Administration** settings page.

Before being registered to your agency, the dock will perform time synchronization against “time.evidence.com.”

The Axon system does not currently support HTTP/HTTPS Proxies. If the dock is placed on a network where a proxy is used to access web sites, the IP assigned to the dock must be whitelisted. Depending on the specific network setup, this may require a static or reserved DHCP IP. We recommend using a DHCP reservation whenever possible to minimize configuration overhead.

Note: If you are using a version of Internet Explorer below 11.0, you will need to enable TLS 1.2. Follow these steps:

- 1 In Internet Explorer, on the **Tools** menu, click **Internet Options**.
- 2 Click **Advanced**.
- 3 Click the **TLS 1.2** check box.

IP Address Configuration

By default the dock uses standard DHCP to obtain an IP address from your agency network. If your agency uses the 10.10.1.x IP address range for your internal department network this may conflict with the default IP Address used by the configuration port (10.10.1.1). In this case it is necessary to set the dock’s configuration network address before connecting the dock to your network the first time.

If you have any questions on setup, call Axon Technical Support at 1-800-978-2737.

Chapter 3: TASER Weapons Dock Installation

Introduction

Installing your TASER Weapons Dock consists of several steps, to be followed in order.

Step 1: Accept the Axon Evidence (Evidence.com) Administrator Invitation

- Ensure that you know your user name, password, and agency domain name.
This email invitation will come from noreply@evidence.com.
- If you do not accept the invitation, you will not be able to complete TASER Weapons Dock setup.

Step 2: Assemble the Dock

- 1 Take the dock out of the box and confirm that all pieces are present.
- 2 Connect your core to all bays you plan to use.

Notes:

- Do not attach more than one multi-bay to one core.
- Do not attach more than one single-bay to one core.
- You should hear a click when pushing the core, bays, and bridge adapters together. If the TASER Weapons Dock assembly does not stay together, press the components together with more force. The parts need to fit flush together.

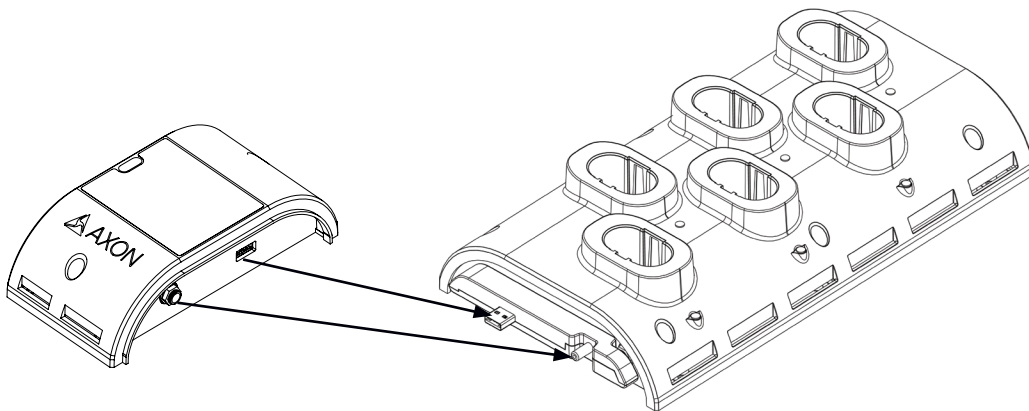

- 3 Turn the dock assembly over so the bottom is facing up.
- 4 Press the locking adapter into place between the core and bay. The two prongs on each end of the locking adapter should snap into place, helping to hold the core and bay together.

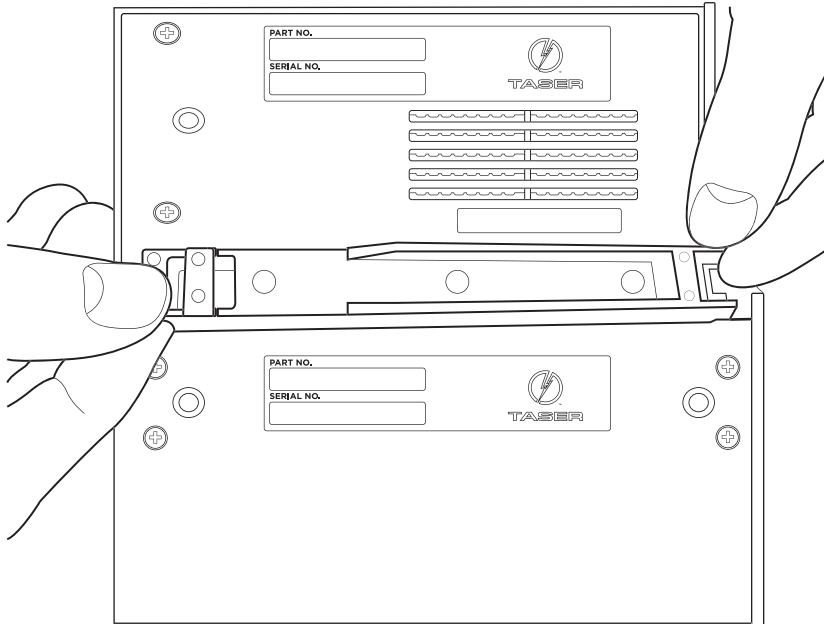

When properly installed, the locking adapter is flush in place with the core and bay.

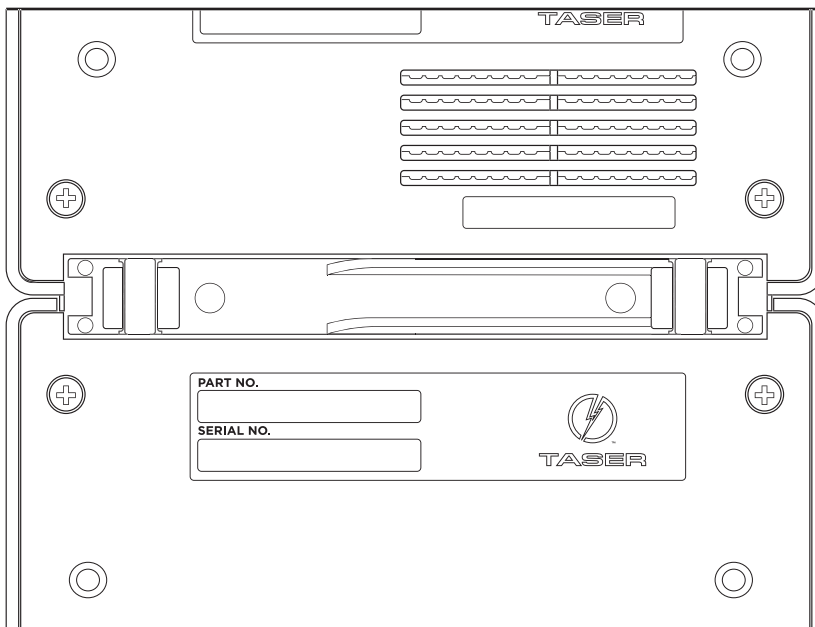

- 5 Place the connected dock on a flat surface, away from heat sources and direct sunlight.
See *Chapter 4: Wall Mounting a TASER Weapons Dock* for additional information on using the Wall Mount.
- 6 Place the dock within reach of appropriate power and Ethernet connections.

Step 3: Connect to the Network

The back of the Axon Dock core has two ports for Ethernet cables, the WAN and MGMT ports.

Note: The USB port on the rear of the core is not currently functional. It is there for future applications.

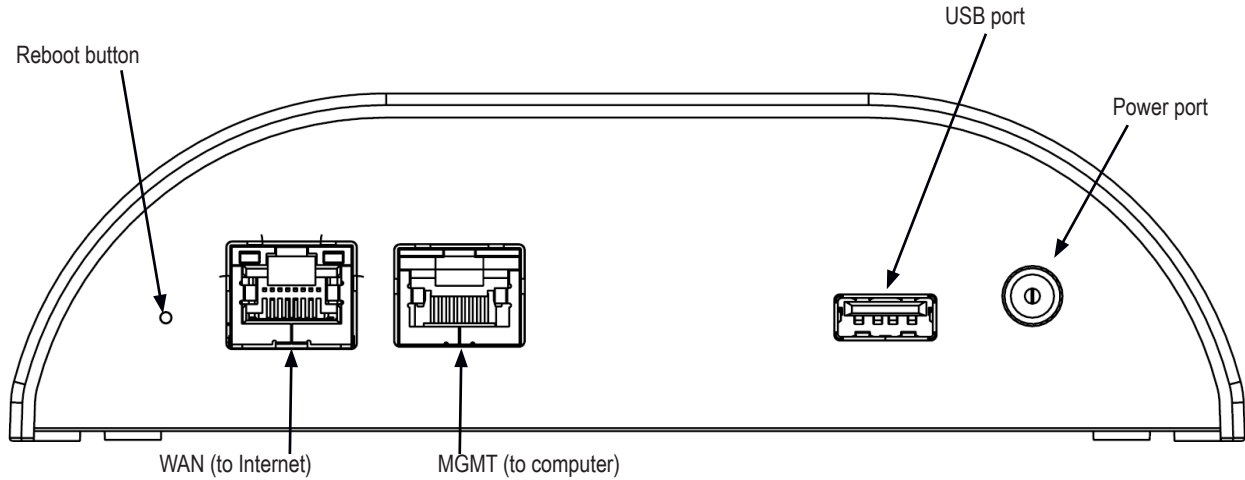

- 1 Plug one of the Ethernet cables into the WAN port.

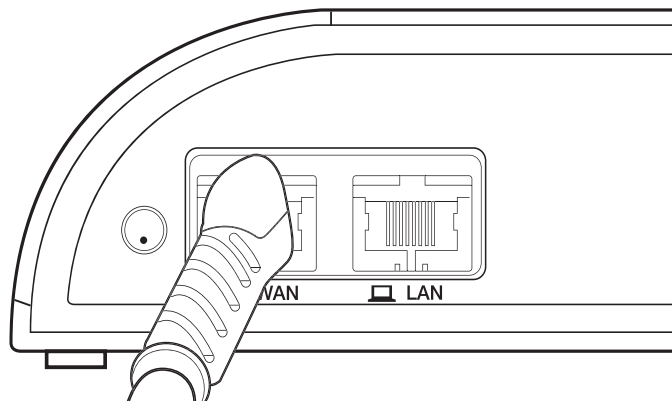

- 2 Plug the other end of this Ethernet cable into an active Internet port, which connects to your agency network.

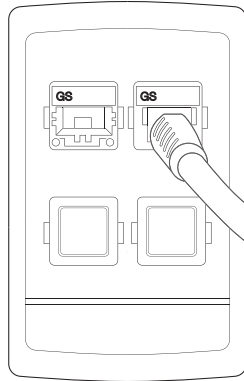

- 3 Plug the other Ethernet cable into the MGMT port.

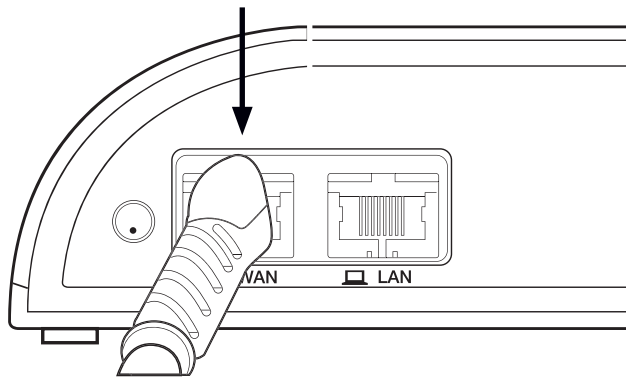

- 4 Plug the other end of this Ethernet cable to your computer.

DO NOT connect the MGMT port to the wall.

Step 4: Connect to Power

- 1 Connect the two segments of the power cord included with the dock.
- 2 Plug the power cord into the core.

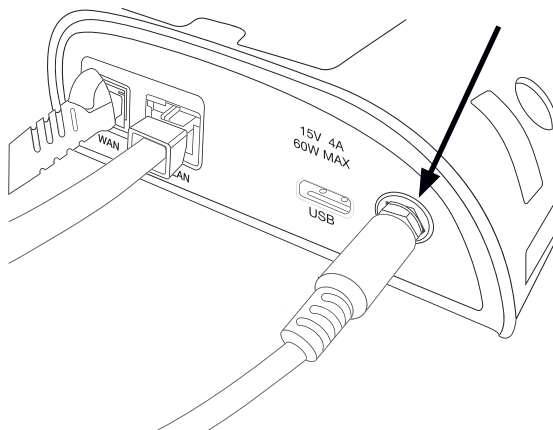

- 3 Connect the other end of the power cord to a standard power outlet.

The green "POWER" LED on top of the core will light up when the dock is powered.

- 4 Give the dock several minutes to fully start.

The green "STATUS" LED on top of the core will light up when the dock has started.

Step 5: Connect to the Dock

- 1 Open a Web browser, such as Google Chrome or Mozilla Firefox.

Notes:

- If you are using Internet Explorer, ensure that you are using version 8 or greater.
- If you have difficulty connecting, see *I cannot reach the status page* (Chapter 6).

- 2 In the URL box, type 10.10.1.1 and press Enter.

- 3 In the Configuration Assistant dialog box, click OK.

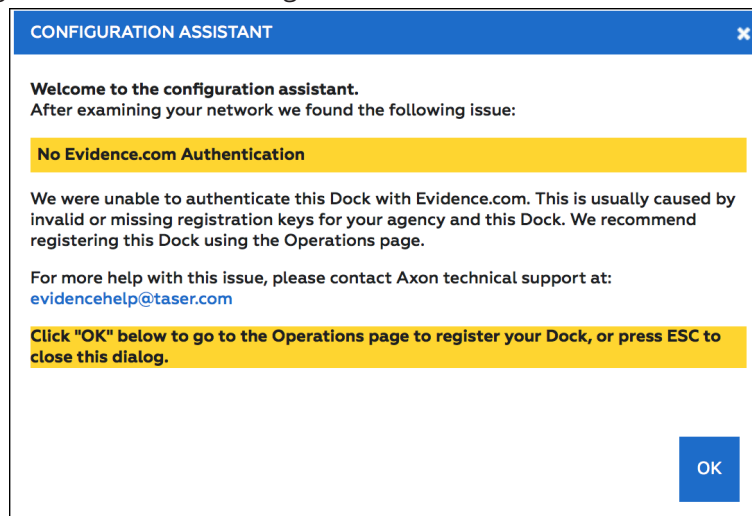

Step 6: Device Configuration

Complete the information for the Authentication Required dialog box:

- 1 In the User Name box, type **admin**.
- 2 In the Password box, type **admin**.
- 3 Click OK.

Note: Axon strongly recommends that you change the password at this time. Go to the **Administration** tab and enter your information, using the existing user name and password. In the Password Change section, type the new password twice and click **Save Changes**.

Ensure that you remember the password. It cannot be reset.

Step 7: Administrator Login

- 1 In the Domain name box type your agency's Evidence.com domain name.
For example, in axon.evidence.com, "axon" is the domain name.

OPERATIONS FIRMWARE VIETNAM – THHUYNH-DOCK-TEST
SCOTTSDALE, AZ
11/25/2021 – 14:56:22

EVIDENCE.COM REGISTRATION

To register this Dock to your Evidence.com Agency enter your Evidence.com agency name. Once the Dock is registered to Evidence.com, it will transfer all media files to your Evidence.com account.

Evidence.com Agency

Domain name

[RESET REGISTRATION](#) [CONTINUE](#)

© 2020 Axon Enterprise, Inc. All rights reserved support@axon.com [Help Center](#)

Note: After 15 minutes of inactivity, the app will open a new tab and ask you to sign back in with your Axon Evidence credentials.

- 2 Click **Continue**.
- 3 Click the link in the “**Please open...**” sentence and use the number provided there to complete registration.

OPERATIONS FIRMWARE VIETNAM – THHUYNH-DOCK-TEST
SCOTTSDALE, AZ
11/29/2021 – 15:28:57

EVIDENCE.COM REGISTRATION

To register this Dock to your Evidence.com Agency enter your Evidence.com agency name. Once the Dock is registered to Evidence.com, it will transfer all media files to your Evidence.com account.

Evidence.com Agency

Domain name

Please open [https://fwn.qa.evidence.com/...](https://fwn.qa.evidence.com/) and provide 123456789 to complete registration.

[RESET REGISTRATION](#) [CONTINUE](#)

© 2020 Axon Enterprise, Inc. All rights reserved support@axon.com [Help Center](#)

Step 8: Registration

The system will then report that it is **Registering the Dock**, then **Generating Security Tokens**, and finally **Restarting the Dock**.

- Allow up to two minutes for the system to restart.

Once the system is ready, the page will refresh and display the message “The Dock has already been registered with Evidence.com.”

On successful registration, a banner displays “This Dock has already been registered with Evidence.com.” Go to *Step 9: Confirm Registration*.

The screenshot shows the Axon Dock web interface. At the top, there is a navigation bar with the Axon Dock logo and menu items: STATUS, NETWORKING, OPERATIONS, ADMINISTRATION, and FIRMWARE. Below the navigation bar, the page title is "OPERATIONS" and the user information is "AXON - SUPERMAN AWARE - X79208918 NEW LOCATION 12/12/2023 - 14:31:10". The main content area is titled "EVIDENCE.COM REGISTRATION" and contains the following text: "To register this Dock to your Evidence.com Agency enter your Evidence.com agency name. Once the Dock is registered to Evidence.com, it will transfer all media files to your Evidence.com account." Below this text, there are two input fields: "Evidence.com Agency" with the value "Axon - Superman Aware" and "Domain name" with the value "supermanaware.evidence.com". A yellow banner with the text "This Dock has already been registered with Evidence.com" is displayed below the input fields. A yellow arrow points to this banner. Below the banner, there is a blue button labeled "RESET REGISTRATION". At the bottom of the page, there is a language dropdown menu set to "English", a copyright notice "© 2023 Axon Enterprise, Inc. All rights reserved", and links for "support@axon.com" and "Help Center".

Step 9: Confirm Registration

- 1 Click **Status** on the top-left part of the screen.
There should be six green check marks on the left side of the screen. This dock is now registered.
- 2 Confirm the dock is connected and the bays are displaying properly.
If there is an issue, the core module's firmware may need to be updated.

SYSTEM STATUS

TASER – HQ
SCOTTSDALE, AZ
12/12/2022 – 16:03:41

NETWORKING

✓	IP Address (dynamic)	10.140.60.105
✓	Internet Gateway	10.140.60.1
✓	DNS Server	10.10.10.151, 10.10.10.150
✓	Time Server	HTTPS/taser.evidence.com
✓	HTTPS (Port 443)	OK/200/0.636053
✓	Evidence.com Registration	Active (TASER)
	MAC Address	14:42:FC:B1:CC:2B
	Serial #	X79127347
	Firmware	3.15.221102.2136

REFRESH

DEVICES

SERIAL #	DEVICE	FIRMWARE*	OWNER	STATUS
X47016641B1	TASER 7 & 10 Charger	2.0.22		Waiting
X47016641B2	TASER 7 & 10 Charger	2.0.22		Waiting
X47016641B3	TASER 7 & 10 Charger	2.0.22		Waiting
X47016641B4	TASER 7 & 10 Charger	2.0.22		Waiting
X47016641B5	TASER 7 & 10 Charger	2.0.22		Waiting
X47016641B6	TASER 7 & 10 Charger	2.0.22		Waiting

Chapter 4: Wall Mounting a TASER Weapons Dock

Safety Instructions

Before mounting your TASER Weapons Dock:

- 1 Ensure that the area behind the wall where the dock will be located is clear of obstructions to avoid damage to surroundings, pipes, or existing wiring.
- 2 Ensure that your cables meet all applicable building and fire codes. For in-wall installation, most require UL-rated wire labeled CL2 or CL3.

Tools and Materials

Tools	Materials
Cable-wire tester/locator Level Pencil Power drill and bits Screwdriver Stud finder Tape measure	Wall Mount Kit

Dimensions

The dimensions below show the mounting hole locations of the Wall Mount Bracket and the overall size of the assembly with the dock attached. The power supply is designed to go behind the unit on the horizontal shelf.

Dimensions for a TASER Weapons Dock Multi-Bay with TASER Battery Packs in a Mounting Bracket

Note: All dimensions are in inches (and centimeters).

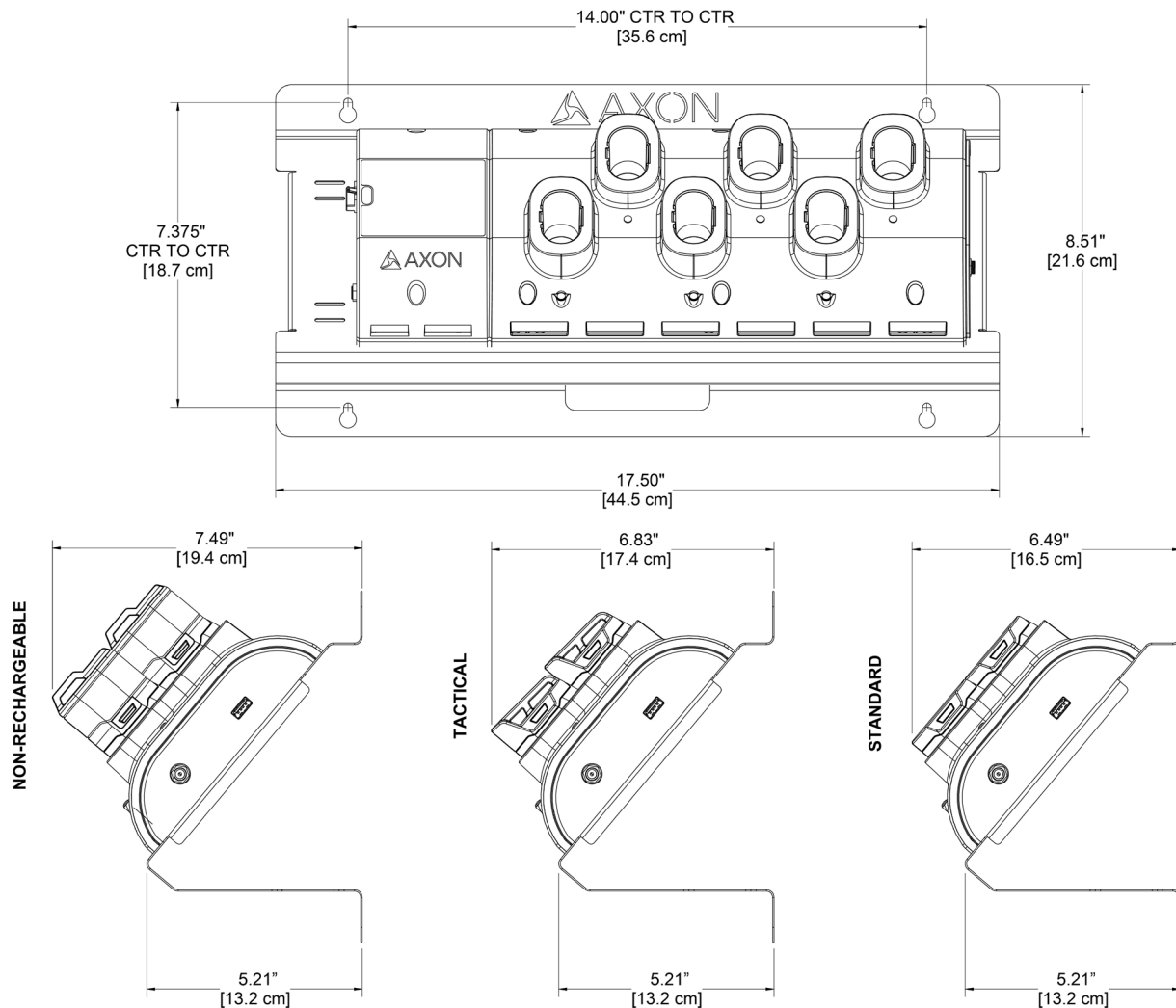

You can use the overall size of the wall mount bracket to determine the spacing and fit between multiple assemblies. The power input and Ethernet input are also shown above.

Step 1: Preparation

- 1 Ensure that you have all necessary hardware and cables required to complete the installation.
- 2 Read all of the manufacturer's installation instructions for both the dock and the Wall Mount Bracket.
- 3 Decide if you will leave the cables showing or hide them in the wall behind your dock.

Step 2: Attach the Dock to the Wall Mount Bracket

- 1 Place your dock on the Wall Mount Bracket.

- 2 Align the holes of the core unit with the holes on the bracket.
- 3 Use the screws provided in the dock wall mount kit to attach and mount the core portion of the dock to the bracket.
- 4 Use the screws, washers, and wing nuts to mount the opposite end bay portion to the bracket.
- 5 Put the screws through the furthest set of mounting holes in the bay (making sure the core and bays are securely mated together).
- 6 As the screws come out the back of the bracket, attach the washers and add the wing nuts.
- 7 Confirm that the core and bay units are securely mated.
- 8 Finish tightening all of the screws.

Step 3: Identify Dock Placement

Determine the best wall location for mounting the dock.

- 1 Look for a location away from heat sources and direct sunlight that does not obstruct movement.
- 2 Choose a location close to an electrical outlet and a network outlet (see *Step 3: Connect to the Network* (Chapter 3) for a picture of an Internet port). Measure the length of the dock's power cord to be sure that it will reach.

Step 4: Attach the Wall Mount Bracket to the Wall (Stud mount)

Your Wall Mount Kit comes with hardware for mounting the bracket to a stud or mounting directly into drywall. If you are going to install the bracket to drywall, go to *Step 5: Attach the Wall Mount Bracket to the Wall (Drywall Mount)*.

Note: Use the longer screw for mounting the bracket into a stud.

- 1 Using a stud finder, mark the location of each stud's center with a pencil.
- 2 Use a nail to confirm a stud has been located.

Note: Depending on the wall construction, you may not be able to mount both ends of the Wall Mount Bracket into the stud.

- 3 Use the drywall anchors in the Wall Mount Kit for the other mounting locations if needed.
- 4 Position the Wall Mount Bracket on the wall and align the mounting keyhole in the left side of the bracket with the center line of the stud.
- 5 Use a level to ensure the bracket is level before marking the holes.
- 6 Mark the center of the left side keyholes in the center of each wall stud.
- 7 Using a power drill, drill a pilot hole smaller than the screw diameter.
- 8 Install the screws into the stud until there is 1/8" (3.2 mm) of space between the bottom of the screw head and the wall.

This will allow the bracket to be placed onto the screws and settle in the keyhole (the holes in the bracket are shaped like keyholes to make it easier to adjust the mount's position on the wall).

- 9 Repeat steps 5–8 for the other side of the mount bracket.

- 10 After the Wall Mount Bracket is positioned correctly, tighten all of the screws.
- 11 Go to *Step 6: Connect the Cables*.

Step 5: Attach the Wall Mount Bracket to the Wall (Drywall Mount)

Your Wall Mount Kit comes with hardware for mounting the bracket to a stud or mounting directly into the drywall. If you are installing the bracket to a wall stud, go to *Step 4: Attach the Wall Mount Bracket to the Wall (Stud mount)*.

Note: Use the screw-in anchors and shorter screws for drywall installation.

- 1 Find the location where you want to mount the Wall Mount Bracket.
- 2 Locate the Wall Mount Bracket on the wall.
- 3 Use a level to ensure the bracket is level before marking the holes.
- 4 Mark the center of the four keyholes on the wall.
- 5 Remove the Wall Mount Bracket and screw in the drywall anchors in each location.
- 6 Screw in each of the screws until there is 1/8" (3.2 mm) of space between the bottom of the screw head and the wall.
- 7 This will allow the bracket to be placed onto the screws and settle in the keyhole.

Step 6: Connect the Cables

- 1 There is space provided on the horizontal shelf to secure the power supply for the dock.
- 2 Position the power supply between the slots in the bracket and secure the power supply to the bracket with the Velcro strap.
- 3 Route the barrel connector around the edge guard and plug the barrel connector into the power jack on the dock.
- 4 You can secure the cable in position with the attached zip tie and the associated slots in the bracket.
- 5 Plug the power supply cable into a power strip or nearby AC outlet.
- 6 Plug the CAT 5e (or better) cable from your agency's network data jack into the WAN port on the dock.
- 7 You can secure the cable in position with the attached zip tie and the associated slots in the bracket.

Removing the Locking Adapters

If it becomes necessary to separate the core from the 6-bay (or individual bay or bays), follow these steps.

- 1 Remove any Axon devices from the bays.
- 2 Unplug all power and network cables from the core.
- 3 Insert a flat-blade screwdriver into the locking adapter.

Do not insert the screwdriver blade past the opening in the locking adapter.

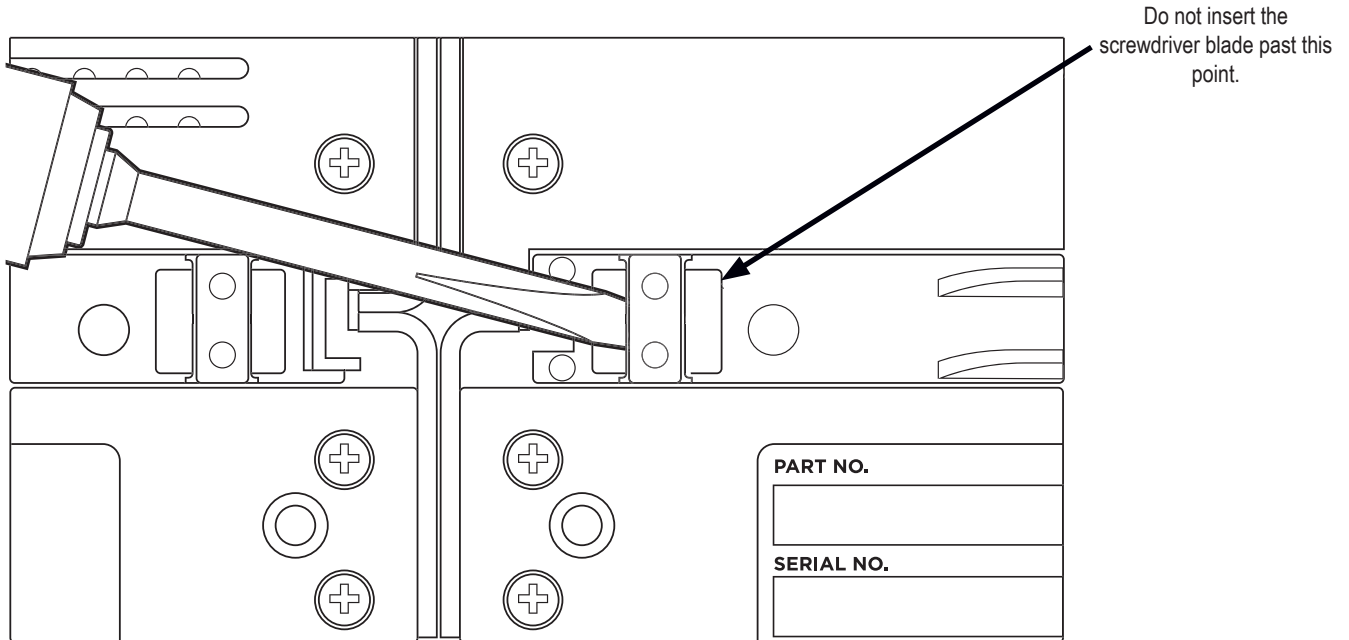

- 4 Turn the screwdriver to lift the locking adapter.

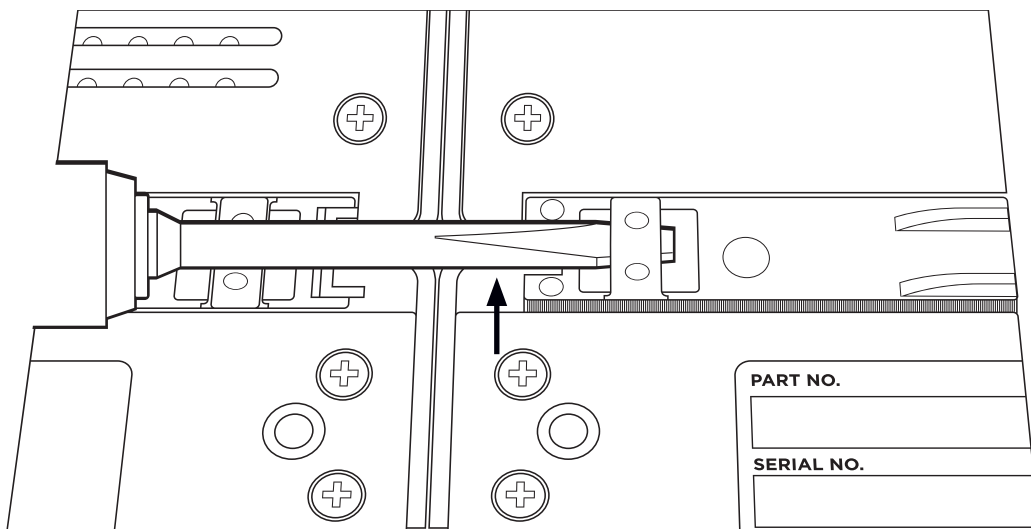

- 5 Repeat steps 3-4 for the other side of the locking adapter.

Chapter 5: Attaching the Desk Plate

Introduction

If you use your TASER Weapons Dock on a desk or table, you should attach your dock to a desk plate. The desk plate holds the core and bay together and keeps the dock from sliding on flat surfaces.

Tools and Materials

Tools	Materials
Screwdriver	Screws Desk plate Rubber feet

Step 1: Preparation

- 1 Ensure you have all the tools necessary to perform this procedure.
- 2 Read all of the manufacturer's installation instructions for the dock. Follow the instructions for putting the dock together in *Chapter 3: TASER Weapons Dock Installation*.
- 3 Place the plate on a table with the flat surface facing up.

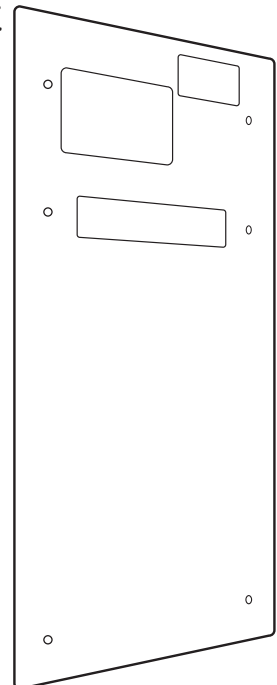

- 4 Place the dock on the desk plate so the openings on the dock are lined up with the holes in the plate.

Note: Ensure the core is placed over the rectangular holes in the plate.

Core

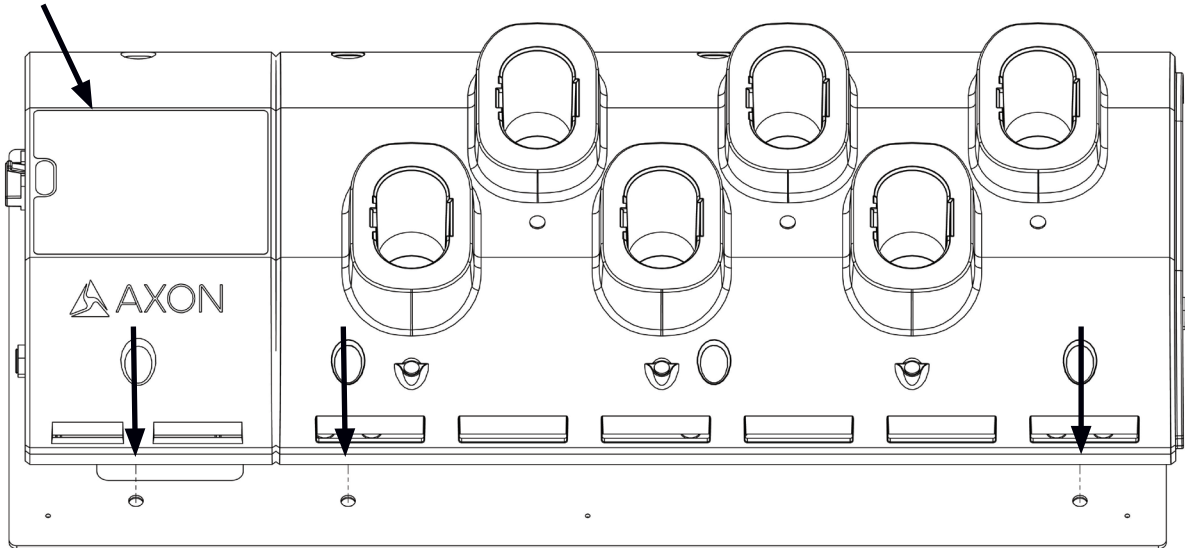

- 5 Ensure the holes in the dock are directly over the holes in the desk plate.
- 6 Use a screwdriver to drive the six screws into the dock.

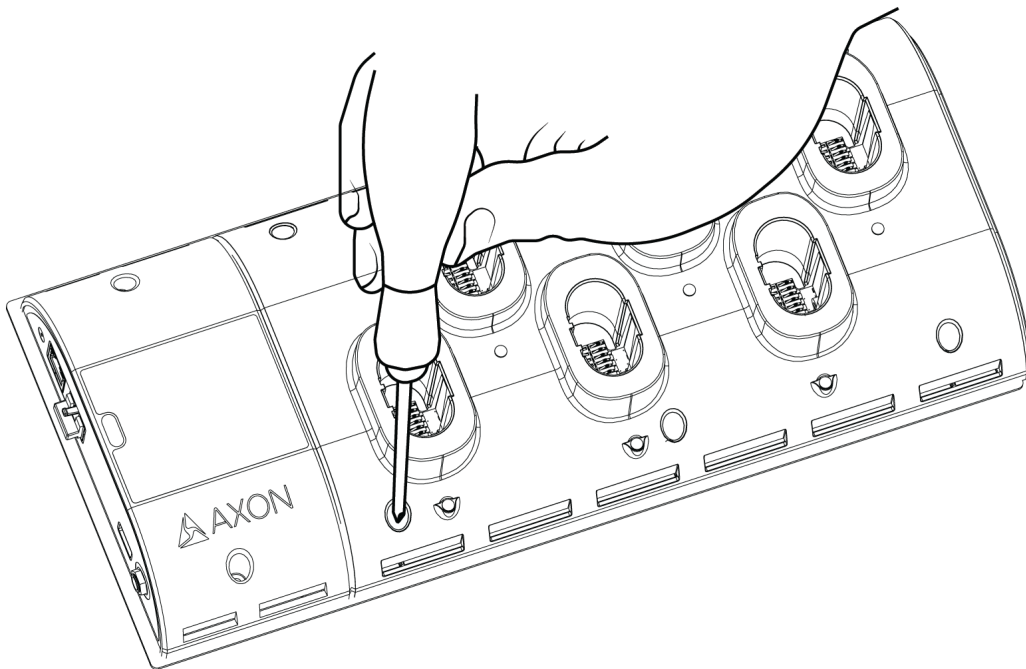

- 7 Turn the dock and desk plate assembly over.
- 8 Remove the adhesive backing from the rubber feet.

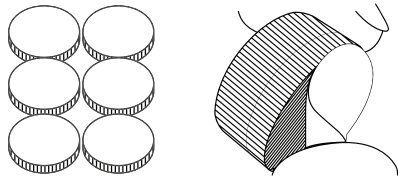

- 9 Place the rubber feet on the desk plate. The metal is scored where the feet are to be located.

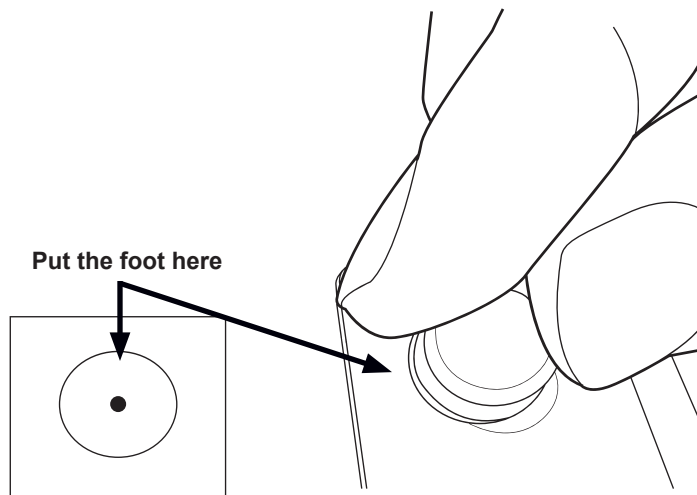

Chapter 6: Troubleshooting the TASER Weapons Dock

I cannot reach the status page

- Ensure that Wi-Fi or any other Internet connection is disabled/disconnected on your computer. If an Internet connection is enabled on your computer, it may interfere with accessing the Axon Evidence (Evidence.com) status page.
- If your agency uses the 10.10.1.1 IP address for internal use, contact Customer Service.
- Ensure that the computer you are connecting to the dock is set to acquire an IP address via DHCP.
- Try another Ethernet cable connecting your computer to the dock.
- Ensure that the dock is plugged into an active power outlet.
- Try accessing <http://10.10.1.1> from a different browser or computer, if possible.

The status page is giving an error

- If you receive an error that indicates anything besides completing the Axon Evidence (Evidence.com) Authentication, please see *Network Requirements* (Chapter 2) to confirm network requirements are met.

I am asked for a user name and password when navigating to 10.10.1.1

- The default user name for the dock is admin and the password is admin. This will be a pop up box after you click OK on the configuration assistant. If you have changed the user name and/or password, you will need to provide the credentials you configured.

I don't know my Agency Domain or User name and Password

- You can find your agency domain by going to <http://prod.Evidence.com> and typing in your email address. It will direct you to your organization's Axon Evidence (Evidence.com) account, thus providing your agency domain name.
- For example, "YourAgencyPD.Evidence.com"
- You must be an Axon Evidence (Evidence.com) Admin in order to register the dock. Your user name and password will be the same login credentials that you use to login to your Axon Evidence (Evidence.com) account.

A battery pack status LED is blinking red, yellow, and green while in a TASER Weapons Dock

- 1 Remove and reseal the battery pack and wait two minutes to see if the condition corrects itself.

- If all the battery packs in the TASER Weapons Dock are blinking red, yellow, and green, there is likely a network or service issue. Check with your agency's IT personnel for any network connectivity issues. If your network is functioning correctly, login to the TASER Weapons Dock and go to the Status page to check the device status. Also, check for any Axon service updates or announcements. If there are no errors, contact Axon Customer Service for any other questions.
- 2 If the battery pack continues to blink red, yellow, and green, place a battery pack that is operating normally in the dock and wait two minutes.
- If the normal operating device blinks red, yellow, and green, there is a network or service issue. Check with your agency IT for any network connectivity issues. If your network is functioning correctly, login to the TASER Weapons Dock and go to the Status page to check the device status. Also, check for any Axon service updates or announcements. If there are no errors, contact Axon Technical Support for any other questions.
 - If the normal operating device is not blinking red, yellow, and green after two minutes, reconnect the original device, login to the TASER Weapons Dock, and go to the Status page to check the device status. If there are no errors, contact Axon Technical Support for assistance.

Status Lights

The core has a power LED to indicate the core is receiving power and a status LED to indicate that the core's software is running.

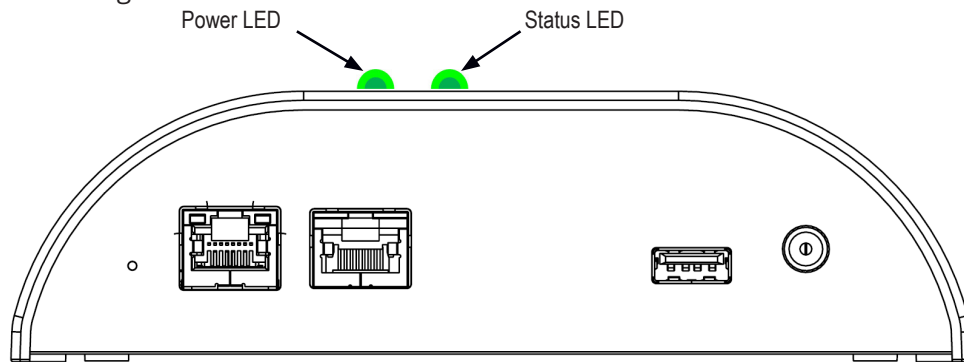

The power LED will be on when the bay is plugged into power. The power LED will be off when the bay is not plugged into power.

The status LED may be green or red, solid or blinking, depending on the dock's system status.

System Status	Status LED Indication
System running	Solid green
System reset	Solid red
Bay(s) reset	Blinking green

Chapter 7: Network Troubleshooting

Status Page Errors

We were unable to obtain an IP address from your DHCP server

Possible Issue	Troubleshooting Steps
Internet port you are using is not active.	Attempt to use a different Internet port, or verify that the current port is active.
Ethernet cable from WAN to Internet port is malfunctioning.	Use a different Ethernet cable.
Agency network only accepts devices with static IP addresses.	You must enter a static IP address, provided by your IT department. For this, click on the networking tab and fill in the required fields.

We were unable to locate a DNS server

Possible Issue	Troubleshooting Steps
Port 53 is blocked.	Confirm that Port 53 is not being restricted by your firewall.
DNS Server address(es) entered incorrectly - <i>This applies only when using Static IP configuration.</i>	Return to the networking tab and verify that the DNS Server address information has been entered correctly.

We were unable to communicate with a network time server

Possible Issue	Troubleshooting Steps
Appropriate port (80 or 443) is blocked.	Confirm that Port 80 or 443 are not being restricted by your firewall.

We were unable to communicate over a secure (HTTPS) channel

Possible Issue	Troubleshooting Steps
Port 443 is blocked.	Confirm that Port 443 is not being restricted by your firewall.

We were unable to contact your network's default gateway

Possible Issue	Troubleshooting Steps
Static IP address entered incorrectly. - <i>This applies only when using Static IP configuration.</i>	Return to the networking tab and confirm that the static IP address has been entered correctly.

Dock Registration Error Codes

Error	Explanation
100010	Invalid Credentials: either a password or username has been entered in incorrectly/misspelled or the domain name is not correct for those login credentials.
100003	A network related issue occurred. If a Static IP address has been assigned to this dock, confirm that all entries are correct and that 2 DNS entries have been added.
100005	There has been too many failed registration attempts. Click the Reset Registration button in the bottom left and once the reset has completed attempt registration again.
100008-1	A network related issue occurred. Reset the dock by pressing the reset button by the WAN port with a paperclip or similar tool. If that does not work, unplug the power for 30 seconds, reconnect the power and allow the dock to reboot (this takes 1-2 minutes). Attempt registration again.
Host Not Found / 100003	No internet connection or the Evidence.com sub-domain name is misspelled or entered in incorrectly. Possible other issues are a bad internet port, a bad Ethernet cable, or an incorrectly entered in Static IP entry.
1060	" ****.evidence.com is not a valid hostname" - the sub-domain name is typed in incorrectly.
Error: 1	" ****.evidence.com is not a valid hostname" - the sub-domain name is typed in incorrectly.
100006	SSL handshake failed - Ensure that your sub-domain name and Evidence.com credentials are all correct.
10020	Access Denied. You do not have permission to view this object: The person attempting to register this dock is not in the default Admin role or their role does not have the Device Administration permission enabled.

Chapter 8: Additional Items

Radio Waves

⚠ CAUTION

Radio Waves. Changes or modifications not expressly approved in writing by the manufacturer could void the user's authority to operate the equipment.

The equipment has been tested and found to comply with the limits for Class A digital devices, pursuant to part 15 of the FCC Rules. These limits are designed to provide reasonable protection against harmful interference when the equipment is operated in a commercial environment. This equipment generates, uses, and can radiate frequency energy and, if not installed and used in accordance with the instruction manual, may cause harmful interference to radio communications. However, there is no guarantee that interference will not occur in a particular installation. Operation of this equipment in a residential area is likely to cause harmful interference in which case the user will be required to correct the interference at his own expense.

This device complies with part 15 of the FCC Rules. Operation is subject to the following two conditions: (1) This device may not cause harmful interference, and (2) this device must accept any interference received, including interference that may cause undesired operation.

Note: Unauthorized modifications could void the warranty and the user's authority to operate the equipment.

Section 8.4 of RSS-GEN

- TASER systems comply with Industry Canada License-exempt RSS standard(s). Operation is subject to the following two conditions: 1) the device may not cause interference, and 2) the device must accept any interference, including interference that may cause undesired operation of the device.
- TASER systems est conforme aux normes d'exemption de licence RSS d'Industrie Canada. Son utilisation est soumise aux conditions suivantes : 1) cet appareil ne doit pas causer de brouillage, et 2) doit accepter tout brouillage, y compris le brouillage pouvant entraîner un fonctionnement indésirable.

Declaration of Conformity

Axon declares that this Axon system is compliant with the requirements of the Electromagnetic Compatibility (EMC) Directive 2014/30/EU of the European Parliament and of the Council. A copy of the original Declaration of Conformity can be found at www.axon.com.

These Class A digital apparatus comply with Canadian ICES-003.

Compliance Marks

CAN ICES-3(A)/NMB-3(A)

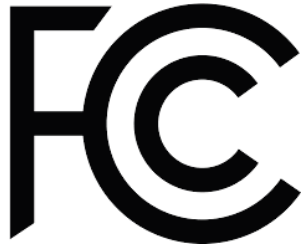

	상호(Company Name) :
	Axon Enterprise, Inc.
	기자재명칭(모델명)(Equipment Name/model Name) :
	TASER Weapons Dock Single Bay / AX1030
	등록번호(KC No.) :
	R-R-CEW-AX1030
제조년월일(Product date) :	
2025/03	
제조사 및 제조국가(Country & Manufacturer) :	
Axon Enterprise, Inc. / USA	

	상호(Company Name) :
	Axon Enterprise, Inc.
	기자재명칭(모델명)(Equipment Name/model Name) :
	TASER Weapons Dock 6 Bay / AX1013
	등록번호(KC No.) :
	R-R-CEW-AX1013
제조년월일(Product date) :	
2025/03	
제조사 및 제조국가(Country & Manufacturer) :	
Axon Enterprise, Inc. / USA	

TASER 10

TASER 7



Axon Enterprise, Inc.
17800 N 85th St
Scottsdale, AZ 85255 USA.

Product functions and specifications may change without notice and the actual product may vary from the illustrations in this manual.

Non-Axon trademarks are property of their respective owners.

▲, ▲ AXON, Axon, Fleet, Axon Flex, Evidence.com, TASER, TASER 7, TASER 10, ⚡ and ⚡ are trademarks of Axon Enterprise Inc., some of which are registered in the US and other countries. For more information, visit www.axon.com/legal. All rights reserved. © 2025 Axon Enterprise, Inc.

MMU0073 Rev: L