



**Boise Cascade**  
Engineered Wood Products

# VERSA-STUD® 1.7 2400 WALL GUIDE

for product manufactured in White City, Oregon

*Stronger  
and  
Stiffer  
for  
Tall Walls  
and  
High Wind  
Loads*

*Straighter  
for  
Cabinet  
and  
Tile Walls*

Better homes from better builders —  
by design . . .

with **VERSA-STUD®** wall framing

VERSA-STUD 1.7 2400  
WALL GUIDE WEST  
12/04/2008 r 03/15/2013

# VERSA-STUD® 1.7 2400

## Engineered Studs for Tall Walls

**VERSA-STUD® 1.7 2400** laminated veneer lumber wall framing is engineered for the high quality builder who wants . . .

- Stronger walls to resist wind loads
- Stiffer walls for a solid feel
- Straight walls for a high quality finish



Long, continuous **VERSA-STUD® 1.7 2400** wall framing will provide superior strength and stiffness in any tall wall application. **VERSA-STUD® 1.7 2400** wall framing provides more resistance to wind pressure than walls framed with dimension lumber and eliminates the hinge created by platform framing. 1 1/2" x 5 1/2" **VERSA-STUD® 1.7 2400** wall framing has two times more bending strength than No. 2 DF 2x6 studs.

Building Code Approved  
for Both Prescriptive and  
Engineered Wall Stud Design

\* 9 1/4" and 11 1/4" depths may be available. Check with supplier or Boise Cascade EWP representative for availability.

Table of Contents

Product profile ..... 2

Prescriptive Design ..... 3

Engineered Design Assumptions for Load Tables ..... 4

Wall Deflection ..... 5

Determining Wind Load ..... 6

Wind Load Definitions ..... 7

VERSA-STUD® & VERSA-LAM® Column Design Example ..... 8

Stud Load Tables - VERSA-STUD® 1.7 2400 1 1/2" x 3 1/2" ..... 9

Stud Load Tables - VERSA-STUD® 1.7 2400 1 1/2" x 5 1/2" ..... 10

Stud Load Tables - VERSA-STUD® 1.7 2400 1 1/2" x 7 1/4" ..... 11

VERSA-STUD® & VERSA-LAM® Column Details ..... 12

VERSA-LAM® 1.7 2650 Exterior Wall Column Table ..... 13

Connectors ..... 14

Connectors / Allowable Holes and Notches ..... 15

Design Properties ..... 16

VERSA-STUD® Wall Sheathing Nailing ..... 17

BC COLUMN™ Software ..... 18

Computer Software ..... 19

Information and Support, SFI, Lifetime Guarantee ..... Back cover

VERSA-STUD® may be used as wall studs in accordance with the prescriptive requirements in section 2308.9 of the IBC and section R602 of the IRC. The table below lists span and spacing limits for prescriptive stud design. Prescriptive design is valid for structures where the wind load does not exceed 110 mph (100 mph in hurricane-

prone regions), the ground snow load does not exceed 70 psf, dead loads on floors or roof do not exceed 20 psf, and several other provisions listed in both building codes. The building design professional of record shall determine whether the structure qualifies for prescriptive design.

| Prescriptive Wall Stud Limits for Conventional Construction |           |             |                  |
|---|-----------|-------------|------------------|
| Wall Type   | Stud Size | Stud Height | Max O.C. Spacing |
| Bearing wall supporting roof and ceiling only               | 1½" x 3½" | 10'         | 24"              |
|   | 1½" x 5½" | 10'         | 24"              |
| Bearing wall supporting one floor only                      | 1½" x 3½" | 10'         | 24"              |
|   | 1½" x 5½" | 10'         | 24"              |
| Bearing wall supporting one floor, roof and ceiling         | 1½" x 3½" | 10'         | 16"              |
|   | 1½" x 5½" | 10'         | 24"              |
| Bearing wall supporting two floors, roof and ceiling        | 1½" x 3½" | 10'         | —                |
|   | 1½" x 5½" | 10'         | 16"              |
| Non-bearing walls   | 1½" x 3½" | 14'         | 24"              |
|   | 1½" x 5½" | 20'         | 24"              |



• Limits per IRC Table R602.3(5)

## Using VERSA-STUD® for Cabinet and Tile Walls

Dimension lumber can exceed 30% moisture content. Wood dries to a moisture content of 10-12% once the building is finished. Shrinkage and warping of 2x studs is a problem in walls where cabinets are hung or tile is installed. Though 2x studs cost less, added labor from shimming cabinets, straightening walls and drywall repairs can quickly add up. VERSA-STUD® eliminates these issues, providing a straight and true wall every time.

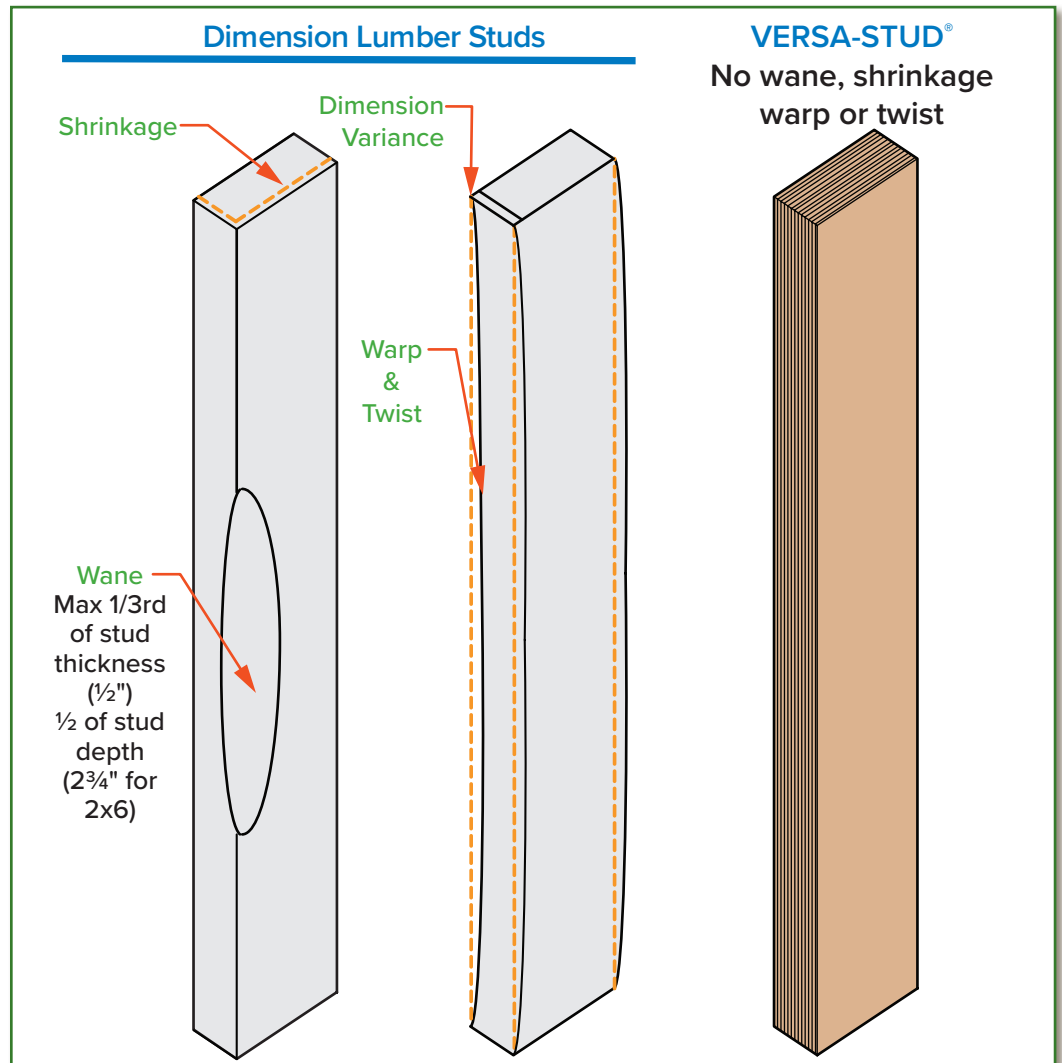

Load table values are based upon axial loads applied at the top of the stud and lateral wind loads perpendicular to the wall (out of plane loading). Lateral loads parallel to the wall (in-plane loading), caused by seismic and wind, shall be designed by the project's design professional of record.

Allowable loads based upon the design provisions of the National Design Specification for Wood Construction (NDS), 2005 edition.

Studs receive axial load concentrically through a double top plate and thus no eccentricity is assumed.

A buckling length coefficient  $K_e$  (based on the fixity of stud ends) is 1.0.

Load table values based upon assumption that stud walls have structural sheathing applied to one side or a combination of non-structural sheathing on the exterior side and gypsum wallboard on the interior side.

Blocking between studs required at a maximum spacing of 8'-0".

The repetitive member factor of 1.04 has been applied to the VERSA-STUD® allowable bending stress.

Wind load duration factor  $C_D = 1.6$ .

Maximum rough opening height of adjoining openings shall not exceed 84".

Double stud members and larger members shown in tables are assumed to be located between openings or at sides of openings. Single stud members shown in tables shall not be used between openings.



## Load Combinations

The allowable design loads shown in this guide are based upon load combination equations for allowable stress design (IBC 06 Section 1605.3.1). Specifically for wall applications:

1. roof dead load + roof live or snow load
2. roof dead load + 0.75 x (roof live or snow load + wind load)
3. 0.6 x dead load + wind load

Since the chances are extremely remote that the maximum roof live or snow load will be present at the same time as a maximum wind load, the IBC allows for a 25% reduction in both loads when applied simultaneously in load combination #2.

## Code References

When calculating deflection from wind, the design wind load is determined by multiplying the Components & Cladding pressure by 0.7 (IBC 06 Table 1604.3, footnote f & IRC 06 Table R301.7, footnote a).



Deflection of individual wall studs is calculated similar to that of joists and beams. The stud height, on-center spacing and stiffness determine the deflection from a design wind load. Below are the building code deflection limit provisions dependent upon the wall coverings.

| Wall Type or Component   | Max Deflection Limit | Corresponding Max Deflection for 20' wall height | Code Reference                               |
|--|----------------------|--|--|
| Exterior Walls with plaster or stucco finish                                   | L/360                | 0.67 in  | IRC 06: Table R301.7                         |
| Exterior walls with brittle finishes (brick and stone veneer - see note below) | L/240                | 1.0 in   | IBC 06: Table 1604.3<br>IRC 06: Table R301.7 |
| Interior walls and partitions  | L/180                | 1.33 in  | IRC 06: Table R301.7                         |
| Mullions (members supporting windows or doors)                                 | L/175                | —  | IRC 06: R613.9.3                             |
| Exterior walls with flexible finishes (lap, panel and metal sidings)           | L/120                | 2.0 in   | IBC 06: Table 1604.3<br>IRC 06: Table R301.7 |

Wall stud deflection may occur both into the structure (positive pressure) or out from the structure (negative pressure). Thus, the total amount of possible movement is actually almost twice the deflection value shown in the design tables (see detail below). As shown in the table above, using the code minimum L/120 limit for 20' stud height can result in a deflection of 2 inches. More restrictive deflection limits may be used, similar to Boise Cascade's Three and Four Star Floor Performance tables for BCI® Joists. The allowable load tables on pages 9-11 provide maximum loads for deflection limits ranging from L/360 to L/120. For applications where a tighter deflection limit is needed, the stud may be designed using the BC COLUMN™ software. As is the case with floors, the deflection of tall walls should be considered in the design phase of the project.

Deflection criteria is used to limit serviceability issues such as doors and windows binding, cracking of exterior and interior surface materials, perceived sounds due to wall movement, glass breaking, wall vibration and movement when pushed on. Wind produces pressure and suction loads on a wall producing deflection inward and outward. Vibration of walls can occur with high span/depth ratios much like a floor joist where depth equals the wall thickness. For further information on wall vibration, please contact Boise Cascade EWP Engineering.

In regards to brick veneer, though the IBC and IRC list a deflection limit of L/240, the Brick Industry Association (BIA) recommends designing studs to a deflection limit of L/600 to limit cracking of the veneer caused by excessive deflection. Such designs may be analyzed using BC COLUMN™ software.

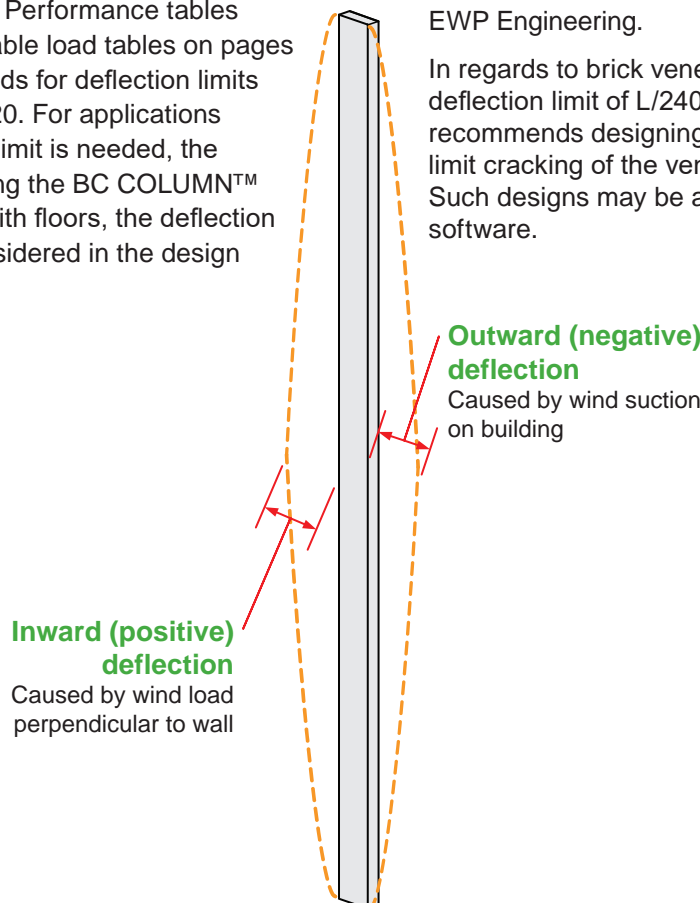

# Determining Wind Load

In some areas the design wind load, in units of psf [lb/ft<sup>2</sup>], is provided for residential construction by the local building code jurisdiction. For example, the State of Oregon Residential Code lists design wind loads for each county, ranging from 15 to 23 psf. *Please refer to the local building code department for such information.*

For areas that do not provide a wind load or for non-residential projects, the wind load may be determined by using the basic wind speed, in units of mph or miles per hour. The wind speed is then converted into a design wind load by calculating all the necessary factors required by ASCE 7, per the IRC and IBC codes. These factors are dependent on the site location of the project and the dimensions of the structure. Typically, the project's design professional of record performs this analysis. The following is an overview of this procedure:

- Determine basic wind speed:** Contour maps are provided in the IRC & IBC. The majority of the inland U.S. has a wind speed of 90 mph. However, basic wind speeds up to 150 mph are required in coastal areas. In addition, special wind region areas exist where the wind speed is higher. Consult with the local building code jurisdiction for the site's design wind speed.
- Determine the project's exposure category:** The exposure of the site will affect the wind load; wind pressure will be less within a subdivision versus a structure near a body of water. For wood-frame buildings, the three exposure categories are defined (see IRC 301.2.1.4 for complete definitions):
  - Exposure B: Urban and suburban (subdivision) areas, forest land.
  - Exposure C: Open terrain with scattered obstructions less than 30 feet tall extending more than 1500 feet from the site in any direction.
  - Exposure D: Flat, unobstructed areas exposed to wind over open water (excluding shorelines in hurricane prone regions) for a distance of at least 1 mile.
- Determine the stud or column's effective wind area:** Calculated using the greater of  $L^{2/3}$  or the tributary area, see Effective Wind Area in Wind Load Definitions, page 7.
- Determine remaining factors:**
  - Importance Factor: 1.0 for most structures, 1.15 for essential service buildings.
  - Topographical Factor: 1.0 for most structures, higher for buildings on hills or ridges.
- Determine mean roof height:** The distance between grade and a midpoint height between the eave and ridge.
- Go to the tables in ASCE 7 to determine the design wind load.** For a mean roof height of 33', importance factor = 1.0 and topographical factor = 1.0, the following table may be used:

| Exposure Category | Effective Wind Area | Wind Design Load [psf] |          |               |          |               |          |               |          |               |          |               |          |               |          |               |          |
|-------------------|---------------------|------------------------|----------|---------------|----------|---------------|----------|---------------|----------|---------------|----------|---------------|----------|---------------|----------|---------------|----------|
|                   |                     | 85 mph                 |          | 90 mph        |          | 100 mph       |          | 110 mph       |          | 120 mph       |          | 130 mph       |          | 140 mph       |          | 150 mph       |          |
|                   |                     | Interior Zone          | End Zone | Interior Zone | End Zone | Interior Zone | End Zone | Interior Zone | End Zone | Interior Zone | End Zone | Interior Zone | End Zone | Interior Zone | End Zone | Interior Zone | End Zone |
| B                 | <=10                | 14.5                   | 17.9     | 16.2          | 20.1     | 20.1          | 24.8     | 24.3          | 30.0     | 28.9          | 35.6     | 33.9          | 41.8     | 39.3          | 48.5     | 45.1          | 55.7     |
|                   | 20                  | 13.9                   | 16.7     | 15.6          | 18.7     | 19.2          | 23.1     | 23.3          | 27.9     | 27.7          | 33.2     | 32.5          | 39.0     | 37.7          | 45.2     | 43.2          | 51.9     |
|                   | 50                  | 13.1                   | 15.1     | 14.7          | 16.9     | 18.1          | 20.9     | 21.6          | 25.3     | 26.1          | 30.1     | 30.6          | 35.3     | 35.5          | 40.9     | 40.8          | 47.0     |
|                   | >=100               | 12.5                   | 13.9     | 14.0          | 15.6     | 17.3          | 19.2     | 20.9          | 23.3     | 24.9          | 27.7     | 29.2          | 32.5     | 33.9          | 37.7     | 38.9          | 43.2     |
| C                 | <=10                | 20.2                   | 24.9     | 22.6          | 27.9     | 27.9          | 34.5     | 33.8          | 41.7     | 40.2          | 49.6     | 47.2          | 58.2     | 54.7          | 67.5     | 62.8          | 77.5     |
|                   | 20                  | 19.3                   | 23.2     | 21.7          | 26.0     | 26.8          | 32.1     | 32.4          | 38.9     | 38.5          | 46.3     | 45.2          | 54.3     | 52.4          | 63.0     | 60.2          | 72.3     |
|                   | 50                  | 18.2                   | 21.0     | 20.4          | 23.6     | 25.2          | 29.1     | 30.5          | 35.2     | 36.3          | 41.9     | 42.6          | 49.1     | 49.4          | 57.0     | 56.8          | 65.4     |
|                   | >=100               | 17.4                   | 19.3     | 19.5          | 21.7     | 24.1          | 26.8     | 29.1          | 32.4     | 34.6          | 38.5     | 40.7          | 45.2     | 47.2          | 52.4     | 54.1          | 60.2     |
| D                 | <=10                | 23.8                   | 29.4     | 26.7          | 32.9     | 32.9          | 40.6     | 39.8          | 49.2     | 47.4          | 58.5     | 55.6          | 68.7     | 64.5          | 79.6     | 74.1          | 91.4     |
|                   | 20                  | 22.8                   | 27.4     | 25.6          | 30.7     | 31.6          | 37.9     | 38.2          | 45.8     | 45.4          | 54.6     | 53.3          | 64.0     | 61.8          | 74.3     | 71.0          | 85.3     |
|                   | 50                  | 21.5                   | 24.8     | 24.1          | 27.8     | 29.7          | 34.3     | 36.0          | 41.5     | 42.8          | 49.4     | 50.3          | 57.9     | 58.3          | 67.2     | 66.9          | 77.1     |
|                   | >=100               | 20.5                   | 22.8     | 23.0          | 25.6     | 28.4          | 31.5     | 34.3          | 38.2     | 40.9          | 45.4     | 48.0          | 53.3     | 55.6          | 61.8     | 63.8          | 71.0     |

- The values shown are based upon the ASCE 7-05 Analytical Procedure, Components & Cladding, Method 2. The corner end zone width of a wall is the smaller of 0.1 x wall length or 0.4 x wall height, but not less than 0.04 x wall length or 3'-0".
- For a mean roof height of 30 feet or less, the stated psf loads in the table above may be reduced 2.5 percent to reflect the values shown in the IRC code.

**ASCE 7:** A design standard published by the American Society of Civil Engineers (ASCE) that is referenced by the International Building Code (IBC). ASCE 7 – Minimum Design Loads for Buildings and Other Structures establishes the live, snow, seismic and wind loads for the building code.

**Components and Cladding (CC):** Structural components that do not qualify on their own as a MWFRS (see below). An individual wall stud is an example of a CC element.

**Effective Wind Area:** A factor used to calculate the wind load on a stud or column. The effective wind area is the greater value of the following two equations:

1. the square of the stud height divided by 3 or  $L^2/3$  (see adjacent value table) or
2. the stud height multiplied by the tributary width (or o.c. spacing for studs).

| Effective Wind Area |  |
|---------------------|--|
| Wall Height [ft]    | Stud/Column Effective Wind Area [ft <sup>2</sup> ] |
| >= 18               | 100  |
| 16                  | 85   |
| 14                  | 65   |
| 12                  | 48   |
| 10                  | 33   |
| 8                   | 21   |

**Exposure Category:** A factor used to calculate the design wind load (pressure) that accounts for the type of terrain surrounding the structure in question. The wind pressure will be less within a housing development versus a structure near a body of water. The following is summary of the exposure categories:

- B = Urban and suburban (subdivision) areas, forest land
- C = Open land with scattered obstructions of heights less than 30 feet
- D = Flat unobstructed areas and water surfaces

**In-Plane Loading:** Lateral loads applied along the length of the wall are referred to as in-plane loading (see detail below). Wind loading applied parallel to the wall length must be determined by the design professional of record. Bracing, braced wall panels and tie-down anchors at corners shall be determined by design professional of record and be in accordance with applicable building code

**Main Wind Force-Resisting System (MWFRS):** A classification of structural components. MWFRS generally refers to a system of elements that receives wind loading from more than one surface of the structure. An example of a MWFRS is an exterior wood shear wall. The shear wall receives seismic and wind load along its length (in-plane loading) and wind load perpendicular to its surface (out-of-plane loading).

**Out-of-Plane Loading:** Wind loading perpendicular to the wall length (see detail below). Tables shown in this guide are based on out-of-plane loading only.

**Wind Speed:** The value established by the building code or local building department which is then used, along with other factors, to determine the wind load. Wind Speed in ASCE 7 is now based upon a 3 second gust, determined by meteorological data and statistical analysis. Wind speed is provided in units of miles per hour (mph).

**Wind Load:** The design load used to size a stud or column. The wind load is determined by taking the wind speed and applying all the necessary factors per ASCE 7, including the geometry of the structure, exposure, etc. In some areas, the design wind load is provided for residential construction by the building code jurisdiction. Wind load is in units of pounds per square foot (psf).

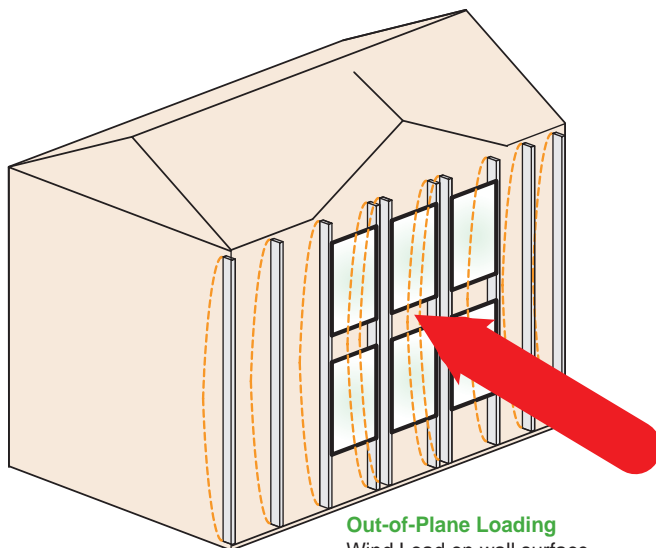

**Out-of-Plane Loading**  
Wind Load on wall surface  
Stress and deflection of studs caused by perpendicular loading

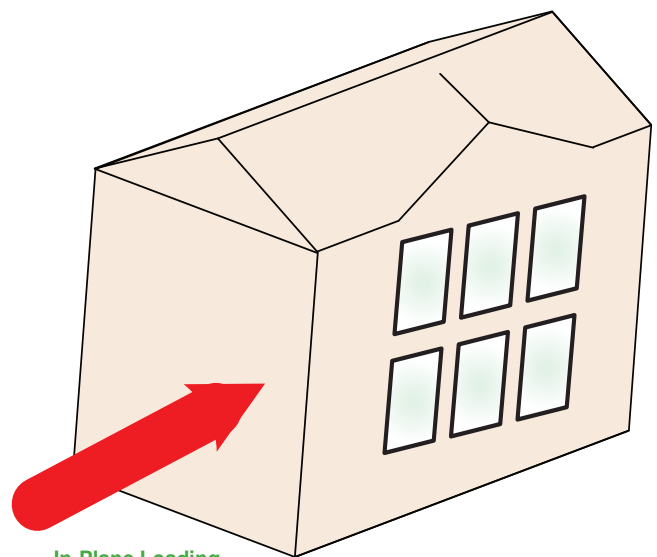

**In-Plane Loading**  
Racking of wall caused by wind and/or seismic loading on opposite wall, applying parallel force on window wall

## VERSA-STUD® Design

**Given: Wall as shown**

**Wall Height:** 16'-0"

**Preliminary Stud Spacing:** 16" o.c.

**Roof Load:** 40 psf snow load, 15 psf dead load. BCI® rafter framing with an 18'-0" horizontal span and 2'-0" overhang

**Wind Load:** 20 psf load per local building department  
(see *wind load section for more information on determining wind loading*)

**Deflection Limit:** Possible brittle finish = L/240  
(IRC Table R301.7)

### Solution:

#### Stud Design

Determine Vertical Load

$$\text{Roof Tributary Width} = [18'-0" / 2] + 2'-0" = 11'-0"$$

$$\text{Snow Load [plf]} = 40 \text{ lb/ft}^2 \times 11 \text{ ft} = 440 \text{ lb/ft}$$

$$\text{Snow Load [lb]} = 440 \text{ lb/ft} \times [16 \text{ in} / 12] = 587 \text{ lb}$$

$$\text{Dead Load [plf]} = 15 \text{ lb/ft}^2 \times 11 \text{ ft} = 165 \text{ lb/ft}$$

$$\text{Wall Weight [lb]} = 10 \text{ lb/ft}^2 \times 16 \text{ ft} \times [16 \text{ in} / 12] = 213 \text{ lb}$$

(assume wall self-weight of 10 psf)

$$\text{Dead Load [lb]} = 165 \text{ lb/ft} \times [16 \text{ in} / 12] = 220 \text{ lb}$$

$$\text{Total Load [lb]} = 587 \text{ lb} + 220 \text{ lb} + 213 \text{ lb} = 1020 \text{ lb}$$

Go to **VERSA-STUD® 1.7 2400 1½" x 5½" load charts, page 10**

L/240, 16 ft wall height

Max. Loading, Single Stud,  
Vertical Load = 3490 lb > 1020 lb **OK!**

20 PSF Wind Load, Max. Stud Spacing = 16" **OK!**

**VERSA-STUD® 1.7 2400 1½" x 5½" @ 16" o.c. OK!**

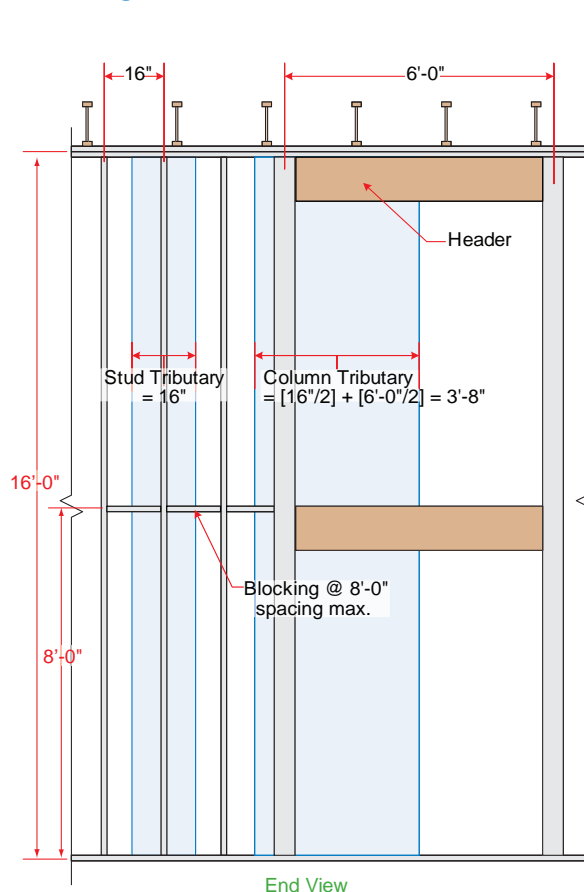

## VERSA-LAM® Column Design

**Determine Vertical Load**

$$\text{Column Tributary Width} = [6'-0" / 2] + [16 \text{ in} / 2] = 3'-8"$$

$$\text{Snow Load [lb]} = 440 \text{ lb/ft} \times 3'-8" = 1615 \text{ lb}$$

$$\text{Dead Load [lb]} = 165 \text{ lb/ft} \times 3'-8" = 606 \text{ lb}$$

$$\text{Total Load [lb]} = 1615 \text{ lb} + 606 \text{ lb} = 2221 \text{ lb}$$

$$\text{Wind Load [plf]} = 20 \text{ lb/ft}^2 \times 3'-8" = 73.4 \text{ lb/ft}$$

Go to **VERSA-LAM® 1.7 2650 Exterior Wall Column Table, page 13**

L/240, 16 ft wall height

### 3½" x 5¼" Column

$$\text{Vertical Load} = 7358 \text{ lb} > 2221 \text{ lb} \text{ OK!}$$

$$\text{Wind Load} = 55.6 \text{ lb/ft} < 73.4 \text{ lb/ft} \text{ NOT OK}$$

### 5¼" x 5¼" Column

$$\text{Vertical Load} = 10680 \text{ lb} > 2221 \text{ lb} \text{ OK!}$$

$$\text{Wind Load} = 83.4 \text{ lb/ft} > 73.4 \text{ lb/ft} \text{ OK!}$$

**VERSA-LAM® 1.7 2650 Column 5¼" x 5¼" OK!**

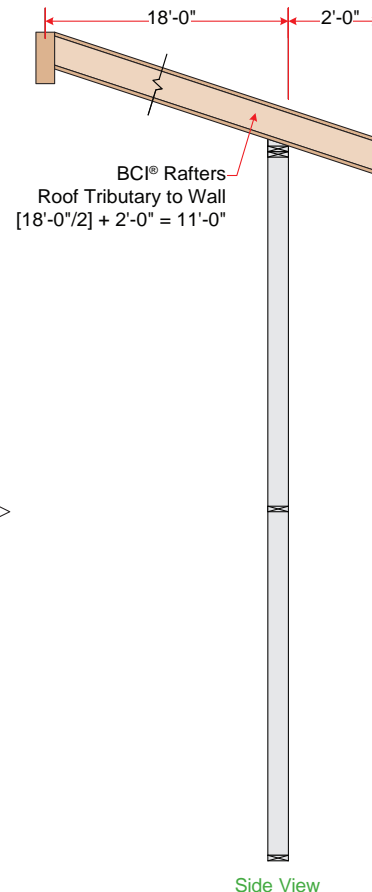

# Stud Load Tables

## VERSA-STUD® 1.7 2400 1½" x 3½"

| Deflection Limit | Wall Height [ft] | MAXIMUM LOADING    |                   |                    |                   | 10 PSF WIND LOAD SPACING & TRIBUTARY |                          |                          | 15 PSF WIND LOAD SPACING & TRIBUTARY |                          |                          | 20 PSF WIND LOAD SPACING & TRIBUTARY |                          |                          |
|------------------|------------------|--------------------|-------------------|--------------------|-------------------|--------------------------------------|--------------------------|--------------------------|--------------------------------------|--------------------------|--------------------------|--------------------------------------|--------------------------|--------------------------|
|                  |                  | Single Stud        |                   | Double Stud        |                   | Single Stud                          |                          | Double Stud              | Single Stud                          |                          | Double Stud              | Single Stud                          |                          | Double Stud              |
|                  |                  | Vertical Load [lb] | Wind Load [lb/ft] | Vertical Load [lb] | Wind Load [lb/ft] | Max Stud Spacing [in]                | Max Tributary Width [in] | Max Tributary Width [in] | Max Stud Spacing [in]                | Max Tributary Width [in] | Max Tributary Width [in] | Max Stud Spacing [in]                | Max Tributary Width [in] | Max Tributary Width [in] |
| L/360            | 8                | 2953               | 37.7              | 4219               | 75.3              | 24                                   | 45.2                     | 90.4                     | 24                                   | 30.1                     | 60.3                     | 19.2                                 | 22.6                     | 45.2                     |
|                  | 9                | 2953               | 26.5              | 4182               | 52.9              | 24                                   | 31.7                     | 63.5                     | 19.2                                 | 21.2                     | 42.3                     | 12                                   | 15.9                     | 31.7                     |
|                  | 10               | 2615               | 19.3              | 4094               | 38.6              | 19.2                                 | 23.1                     | 46.3                     | 12                                   | 15.4                     | 30.9                     | 8                                    | 11.6                     | 23.1                     |
|                  | 11               | 2211               | 14.5              | 3943               | 29.0              | 16                                   | 17.4                     | 34.8                     | 8                                    | 11.6                     | 23.2                     | 8                                    | 8.7                      | 17.4                     |
|                  | 12               | 1894               | 11.2              | 3720               | 22.3              | 12                                   | 13.4                     | 26.8                     | 8                                    | 8.9                      | 17.9                     | 6                                    | 6.7                      | 13.4                     |
|                  | 13               | 1641               | 8.8               | 3248               | 17.6              | 8                                    | 10.5                     | 21.1                     | 6                                    | 7.0                      | 14.0                     | 4                                    | 5.3                      | 10.5                     |
|                  | 14               | 1435               | 7.0               | 2843               | 14.1              | 8                                    | 8.4                      | 16.9                     | 4                                    | 5.6                      | 11.2                     | 4                                    | 4.2                      | 8.4                      |
| L/240            | 8                | 2953               | 56.5              | 3785               | 113.0             | 24                                   | 67.8                     | 135.6                    | 24                                   | 45.2                     | 90.4                     | 24                                   | 33.9                     | 67.8                     |
|                  | 9                | 2762               | 39.7              | 3764               | 79.4              | 24                                   | 47.6                     | 95.2                     | 24                                   | 31.7                     | 63.5                     | 19.2                                 | 23.8                     | 47.6                     |
|                  | 10               | 2329               | 28.9              | 3687               | 57.8              | 24                                   | 34.7                     | 69.4                     | 19.2                                 | 23.1                     | 46.3                     | 16                                   | 17.4                     | 34.7                     |
|                  | 11               | 1988               | 21.7              | 3549               | 43.5              | 24                                   | 26.1                     | 52.2                     | 16                                   | 17.4                     | 34.8                     | 12                                   | 13.0                     | 26.1                     |
|                  | 12               | 1716               | 16.7              | 3357               | 33.5              | 19.2                                 | 20.1                     | 40.2                     | 12                                   | 13.4                     | 26.8                     | 8                                    | 10.0                     | 20.1                     |
|                  | 13               | 1496               | 13.2              | 2951               | 26.3              | 12                                   | 15.8                     | 31.6                     | 8                                    | 10.5                     | 21.1                     | 6                                    | 7.9                      | 15.8                     |
|                  | 14               | 1317               | 10.5              | 2598               | 21.1              | 12                                   | 12.6                     | 25.3                     | 8                                    | 8.4                      | 16.9                     | 6                                    | 6.3                      | 12.6                     |
| L/180            | 8                | 2861               | 75.3              | 3352               | 150.6             | 24                                   | 90.4                     | 180.8                    | 24                                   | 60.3                     | 120.5                    | 24                                   | 45.2                     | 90.4                     |
|                  | 9                | 2426               | 52.9              | 3361               | 105.8             | 24                                   | 63.5                     | 127.0                    | 24                                   | 42.3                     | 84.6                     | 24                                   | 31.7                     | 63.5                     |
|                  | 10               | 2075               | 38.6              | 3306               | 77.1              | 24                                   | 46.3                     | 92.6                     | 24                                   | 30.9                     | 61.7                     | 19.2                                 | 23.1                     | 46.3                     |
|                  | 11               | 1791               | 29.0              | 3195               | 57.9              | 24                                   | 34.8                     | 69.5                     | 19.2                                 | 23.2                     | 46.4                     | 16                                   | 17.4                     | 34.8                     |
|                  | 12               | 1560               | 22.3              | 3036               | 44.6              | 24                                   | 26.8                     | 53.6                     | 16                                   | 17.9                     | 35.7                     | 12                                   | 13.4                     | 26.8                     |
|                  | 13               | 1370               | 17.6              | 2689               | 35.1              | 19.2                                 | 21.1                     | 42.1                     | 12                                   | 14.0                     | 28.1                     | 8                                    | 10.5                     | 21.1                     |
|                  | 14               | 1212               | 14.1              | 2381               | 28.1              | 16                                   | 16.9                     | 33.7                     | 8                                    | 11.2                     | 22.5                     | 8                                    | 8.4                      | 16.9                     |
| L/120            | 8                | 2002               | 113.0             | 2443               | 226.0             | 24                                   | 135.6                    | 271.2                    | 24                                   | 90.4                     | 180.8                    | 24                                   | 67.8                     | 135.6                    |
|                  | 9                | 1809               | 79.4              | 2558               | 158.7             | 24                                   | 95.2                     | 190.4                    | 24                                   | 63.5                     | 127.0                    | 24                                   | 47.6                     | 95.2                     |
|                  | 10               | 1614               | 57.8              | 2584               | 115.7             | 24                                   | 69.4                     | 138.8                    | 24                                   | 46.3                     | 92.6                     | 24                                   | 34.7                     | 69.4                     |
|                  | 11               | 1436               | 43.5              | 2546               | 86.9              | 24                                   | 52.2                     | 104.3                    | 24                                   | 34.8                     | 69.5                     | 24                                   | 26.1                     | 52.2                     |
|                  | 12               | 1280               | 33.5              | 2460               | 67.0              | 24                                   | 40.2                     | 80.3                     | 24                                   | 26.8                     | 53.6                     | 19.2                                 | 20.1                     | 40.2                     |
|                  | 13               | 1144               | 26.3              | 2220               | 52.7              | 24                                   | 31.6                     | 63.2                     | 19.2                                 | 21.1                     | 42.1                     | 12                                   | 15.8                     | 31.6                     |
|                  | 14               | 1027               | 21.1              | 1998               | 42.2              | 24                                   | 25.3                     | 50.6                     | 16                                   | 16.9                     | 33.7                     | 12                                   | 12.6                     | 25.3                     |

| Deflection Limit | Wall Height [ft] | MAXIMUM LOADING    |                   |                    |                   | 25 PSF WIND LOAD SPACING & TRIBUTARY |                          |                          | 30 PSF WIND LOAD SPACING & TRIBUTARY |                          |                          | 40 PSF WIND LOAD SPACING & TRIBUTARY |                          |                          |
|------------------|------------------|--------------------|-------------------|--------------------|-------------------|--------------------------------------|--------------------------|--------------------------|--------------------------------------|--------------------------|--------------------------|--------------------------------------|--------------------------|--------------------------|
|                  |                  | Single Stud        |                   | Double Stud        |                   | Single Stud                          |                          | Double Stud              | Single Stud                          |                          | Double Stud              | Single Stud                          |                          | Double Stud              |
|                  |                  | Vertical Load [lb] | Wind Load [lb/ft] | Vertical Load [lb] | Wind Load [lb/ft] | Max Stud Spacing [in]                | Max Tributary Width [in] | Max Tributary Width [in] | Max Stud Spacing [in]                | Max Tributary Width [in] | Max Tributary Width [in] | Max Stud Spacing [in]                | Max Tributary Width [in] | Max Tributary Width [in] |
| L/360            | 8                | 2953               | 37.7              | 4219               | 75.3              | 16                                   | 18.1                     | 36.2                     | 12                                   | 15.1                     | 30.1                     | 8                                    | 11.3                     | 22.6                     |
|                  | 9                | 2953               | 26.5              | 4182               | 52.9              | 12                                   | 12.7                     | 25.4                     | 8                                    | 10.6                     | 21.2                     | 6                                    | 7.9                      | 15.9                     |
|                  | 10               | 2615               | 19.3              | 4094               | 38.6              | 8                                    | 9.3                      | 18.5                     | 6                                    | 7.7                      | 15.4                     | 4                                    | 5.8                      | 11.6                     |
|                  | 11               | 2211               | 14.5              | 3943               | 29.0              | 6                                    | 7.0                      | 13.9                     | 4                                    | 5.8                      | 11.6                     | 4                                    | 4.3                      | 8.7                      |
|                  | 12               | 1894               | 11.2              | 3720               | 22.3              | 4                                    | 5.4                      | 10.7                     | 4                                    | 4.5                      | 8.9                      | --                                   | 3.3                      | 6.7                      |
|                  | 13               | 1641               | 8.8               | 3248               | 17.6              | 4                                    | 4.2                      | 8.4                      | --                                   | 3.5                      | 7.0                      | --                                   | 2.6                      | 5.3                      |
|                  | 14               | 1435               | 7.0               | 2843               | 14.1              | --                                   | 3.4                      | 6.7                      | --                                   | 2.8                      | 5.6                      | --                                   | 2.1                      | 4.2                      |
| L/240            | 8                | 2953               | 56.5              | 3785               | 113.0             | 24                                   | 27.1                     | 54.2                     | 19.2                                 | 22.6                     | 45.2                     | 16                                   | 16.9                     | 33.9                     |
|                  | 9                | 2762               | 39.7              | 3764               | 79.4              | 16                                   | 19.0                     | 38.1                     | 12                                   | 15.9                     | 31.7                     | 8                                    | 11.9                     | 23.8                     |
|                  | 10               | 2329               | 28.9              | 3687               | 57.8              | 12                                   | 13.9                     | 27.8                     | 8                                    | 11.6                     | 23.1                     | 8                                    | 8.7                      | 17.4                     |
|                  | 11               | 1988               | 21.7              | 3549               | 43.5              | 8                                    | 10.4                     | 20.9                     | 8                                    | 8.7                      | 17.4                     | 6                                    | 6.5                      | 13.0                     |
|                  | 12               | 1716               | 16.7              | 3357               | 33.5              | 8                                    | 8.0                      | 16.1                     | 6                                    | 6.7                      | 13.4                     | 4                                    | 5.0                      | 10.0                     |
|                  | 13               | 1496               | 13.2              | 2951               | 26.3              | 6                                    | 6.3                      | 12.6                     | 4                                    | 5.3                      | 10.5                     | --                                   | 3.9                      | 7.9                      |
|                  | 14               | 1317               | 10.5              | 2598               | 21.1              | 4                                    | 5.1                      | 10.1                     | 4                                    | 4.2                      | 8.4                      | --                                   | 3.2                      | 6.3                      |
| L/180            | 8                | 2861               | 75.3              | 3352               | 150.6             | 24                                   | 36.2                     | 72.3                     | 24                                   | 30.1                     | 60.3                     | 19.2                                 | 22.6                     | 45.2                     |
|                  | 9                | 2426               | 52.9              | 3361               | 105.8             | 24                                   | 25.4                     | 50.8                     | 19.2                                 | 21.2                     | 42.3                     | 12                                   | 15.9                     | 31.7                     |
|                  | 10               | 2075               | 38.6              | 3306               | 77.1              | 16                                   | 18.5                     | 37.0                     | 12                                   | 15.4                     | 30.9                     | 8                                    | 11.6                     | 23.1                     |
|                  | 11               | 1791               | 29.0              | 3195               | 57.9              | 12                                   | 13.9                     | 27.8                     | 8                                    | 11.6                     | 23.2                     | 8                                    | 8.7                      | 17.4                     |
|                  | 12               | 1560               | 22.3              | 3036               | 44.6              | 8                                    | 10.7                     | 21.4                     | 8                                    | 8.9                      | 17.9                     | 6                                    | 6.7                      | 13.4                     |
|                  | 13               | 1370               | 17.6              | 2689               | 35.1              | 8                                    | 8.4                      | 16.9                     | 6                                    | 7.0                      | 14.0                     | 4                                    | 5.3                      | 10.5                     |
|                  | 14               | 1212               | 14.1              | 2381               | 28.1              | 6                                    | 6.7                      | 13.5                     | 4                                    | 5.6                      | 11.2                     | 4                                    | 4.2                      | 8.4                      |
| L/120            | 8                | 2002               | 113.0             | 2443               | 226.0             | 24                                   | 54.2                     | 108.5                    | 24                                   | 45.2                     | 90.4                     | 24                                   | 33.9                     | 67.8                     |
|                  | 9                | 1809               | 79.4              | 2558               | 158.7             | 24                                   | 38.1                     | 76.2                     | 24                                   | 31.7                     | 63.5                     | 19.2                                 | 23.8                     | 47.6                     |
|                  | 10               | 1614               | 57.8              | 2584               | 115.7             | 24                                   | 27.8                     | 55.5                     | 19.2                                 | 23.1                     | 46.3                     | 16                                   | 17.4                     | 34.7                     |
|                  | 11               | 1436               | 43.5              | 2546               | 86.9              | 19.2                                 | 20.9                     | 41.7                     | 16                                   | 17.4                     | 34.8                     | 12                                   | 13.0                     | 26.1                     |
|                  | 12               | 1280               | 33.5              | 2460               | 67.0              | 16                                   | 16.1                     | 32.1                     | 12                                   | 13.4                     | 26.8                     | 8                                    | 10.0                     | 20.1                     |
|                  | 13               | 1144               | 26.3              | 2220               | 52.7              | 12                                   | 12.6                     | 25.3                     | 8                                    | 10.5                     | 21.1                     | 6                                    | 7.9                      | 15.8                     |
|                  | 14               | 1027               | 21.1              | 1998               | 42.2              | 8                                    | 10.1                     | 20.2                     | 8                                    | 8.4                      | 16.9                     | 6                                    | 6.3                      | 12.6                     |

**Notes**

- Wall stud analysis per 2005 National Design Specification (NDS) for Wood Construction.
- For 3-ply and 4-ply built up columns, multiply double stud table values by 1.5 and 2.0.
- Full depth blocking required at a maximum spacing of 8'-0" for single studs.
- Structural sheathing or structural siding installed on one side of wall.

- Double stud values assume unsupported lateral length of 7'-0".
- Table assumes wind load duration factor of 1.6 and vertical load duration factor of 1.0.
- Table assumes compression perpendicular to grain for plate of 450 psi.
- Vertical dead load may not exceed 50% of the total vertical load.
- Repetitive member increase for bending (1.04) applied to single studs only.
- Compression perpendicular to grain stress adjusted per NDS 3.10.4 for single studs only.

# Stud Load Tables

## VERSA-STUD® 1.7 2400 1½" x 5½"

| Deflection Limit | Wall Height [ft] | MAXIMUM LOADING    |                   |                    |                   | 10 PSF WIND LOAD SPACING & TRIBUTARY |                          |                          | 15 PSF WIND LOAD SPACING & TRIBUTARY |                          |                          | 20 PSF WIND LOAD SPACING & TRIBUTARY |                          |                          |
|------------------|------------------|--------------------|-------------------|--------------------|-------------------|--------------------------------------|--------------------------|--------------------------|--------------------------------------|--------------------------|--------------------------|--------------------------------------|--------------------------|--------------------------|
|                  |                  | Single Stud        |                   | Double Stud        |                   | Single Stud                          |                          | Double Stud              | Single Stud                          |                          | Double Stud              | Single Stud                          |                          | Double Stud              |
|                  |                  | Vertical Load [lb] | Wind Load [lb/ft] | Vertical Load [lb] | Wind Load [lb/ft] | Max Stud Spacing [in]                | Max Tributary Width [in] | Max Tributary Width [in] | Max Stud Spacing [in]                | Max Tributary Width [in] | Max Tributary Width [in] | Max Stud Spacing [in]                | Max Tributary Width [in] | Max Tributary Width [in] |
| L/360            | 10               | 4641               | 74.8              | 6469               | 149.6             | 24                                   | 89.8                     | 179.6                    | 24                                   | 59.9                     | 119.7                    | 24                                   | 44.9                     | 89.8                     |
|                  | 12               | 4641               | 43.3              | 6542               | 86.6              | 24                                   | 52.0                     | 103.9                    | 24                                   | 34.6                     | 69.3                     | 24                                   | 26.0                     | 52.0                     |
|                  | 14               | 4641               | 27.3              | 6495               | 54.5              | 24                                   | 32.7                     | 65.4                     | 19.2                                 | 21.8                     | 43.6                     | 16                                   | 16.4                     | 32.7                     |
|                  | 16               | 3933               | 18.3              | 6313               | 36.5              | 19.2                                 | 21.9                     | 43.8                     | 12                                   | 14.6                     | 29.2                     | 8                                    | 11.0                     | 21.9                     |
|                  | 17               | 3537               | 15.2              | 6163               | 30.5              | 16                                   | 18.3                     | 36.6                     | 12                                   | 12.2                     | 24.4                     | 8                                    | 9.1                      | 18.3                     |
|                  | 18               | 3198               | 12.8              | 5969               | 25.7              | 12                                   | 15.4                     | 30.8                     | 8                                    | 10.3                     | 20.5                     | 6                                    | 7.7                      | 15.4                     |
|                  | 19               | 2906               | 10.9              | 5732               | 21.8              | 12                                   | 13.1                     | 26.2                     | 8                                    | 8.7                      | 17.5                     | 6                                    | 6.5                      | 13.1                     |
| 20               | 2651             | 9.4                | 5234              | 18.7               | 8                 | 11.2                                 | 22.4                     | 6                        | 7.5                                  | 15.0                     | 4                        | 5.6                                  | 11.2                     |                          |
| L/240            | 10               | 4641               | 112.2             | 5638               | 224.5             | 24                                   | 134.7                    | 269.4                    | 24                                   | 89.8                     | 179.6                    | 24                                   | 67.3                     | 134.7                    |
|                  | 12               | 4641               | 65.0              | 5804               | 129.9             | 24                                   | 77.9                     | 155.9                    | 24                                   | 52.0                     | 103.9                    | 24                                   | 39.0                     | 77.9                     |
|                  | 14               | 4324               | 40.9              | 5800               | 81.8              | 24                                   | 49.1                     | 98.2                     | 24                                   | 32.7                     | 65.4                     | 24                                   | 24.5                     | 49.1                     |
|                  | 16               | 3490               | 27.4              | 5645               | 54.8              | 24                                   | 32.9                     | 65.8                     | 19.2                                 | 21.9                     | 43.8                     | 16                                   | 16.4                     | 32.9                     |
|                  | 17               | 3160               | 22.8              | 5512               | 45.7              | 24                                   | 27.4                     | 54.8                     | 16                                   | 18.3                     | 36.6                     | 12                                   | 13.7                     | 27.4                     |
|                  | 18               | 2873               | 19.2              | 5345               | 38.5              | 19.2                                 | 23.1                     | 46.2                     | 12                                   | 15.4                     | 30.8                     | 8                                    | 11.5                     | 23.1                     |
|                  | 19               | 2624               | 16.4              | 5142               | 32.7              | 19.2                                 | 19.6                     | 39.3                     | 12                                   | 13.1                     | 26.2                     | 8                                    | 9.8                      | 19.6                     |
| 20               | 2405             | 14.0               | 4721              | 28.1               | 16                | 16.8                                 | 33.7                     | 8                        | 11.2                                 | 22.4                     | 8                        | 8.4                                  | 16.8                     |                          |
| L/180            | 10               | 4641               | 149.6             | 4744               | 299.3             | 24                                   | 179.6                    | 359.2                    | 24                                   | 119.7                    | 239.4                    | 24                                   | 89.8                     | 179.6                    |
|                  | 12               | 4620               | 86.6              | 5049               | 173.2             | 24                                   | 103.9                    | 207.8                    | 24                                   | 69.3                     | 138.6                    | 24                                   | 52.0                     | 103.9                    |
|                  | 14               | 3759               | 54.5              | 5122               | 109.1             | 24                                   | 65.4                     | 130.9                    | 24                                   | 43.6                     | 87.3                     | 24                                   | 32.7                     | 65.4                     |
|                  | 16               | 3097               | 36.5              | 5025               | 73.1              | 24                                   | 43.8                     | 87.7                     | 24                                   | 29.2                     | 58.5                     | 19.2                                 | 21.9                     | 43.8                     |
|                  | 17               | 2825               | 30.5              | 4921               | 60.9              | 24                                   | 36.6                     | 73.1                     | 24                                   | 24.4                     | 48.7                     | 16                                   | 18.3                     | 36.6                     |
|                  | 18               | 2586               | 25.7              | 4786               | 51.3              | 24                                   | 30.8                     | 61.6                     | 19.2                                 | 20.5                     | 41.1                     | 12                                   | 15.4                     | 30.8                     |
|                  | 19               | 2374               | 21.8              | 4624               | 43.6              | 24                                   | 26.2                     | 52.4                     | 16                                   | 17.5                     | 34.9                     | 12                                   | 13.1                     | 26.2                     |
| 20               | 2187             | 18.7               | 4265              | 37.4               | 19.2              | 22.4                                 | 44.9                     | 12                       | 15.0                                 | 29.9                     | 8                        | 11.2                                 | 22.4                     |                          |
| L/120            | 10               | 3091               | 219.6             | 2758               | 422.3             | 24                                   | 263.5                    | 506.7                    | 24                                   | 179.6                    | 359.2                    | 24                                   | 134.7                    | 269.4                    |
|                  | 12               | 3006               | 129.9             | 3424               | 259.8             | 24                                   | 155.9                    | 311.8                    | 24                                   | 103.9                    | 207.8                    | 24                                   | 77.9                     | 155.9                    |
|                  | 14               | 2721               | 81.8              | 3760               | 163.6             | 24                                   | 98.2                     | 196.3                    | 24                                   | 65.4                     | 130.9                    | 24                                   | 49.1                     | 98.2                     |
|                  | 16               | 2380               | 54.8              | 3849               | 109.6             | 24                                   | 65.8                     | 131.5                    | 24                                   | 43.8                     | 87.7                     | 24                                   | 32.9                     | 65.8                     |
|                  | 17               | 2219               | 45.7              | 3826               | 91.4              | 24                                   | 54.8                     | 109.7                    | 24                                   | 36.6                     | 73.1                     | 24                                   | 27.4                     | 54.8                     |
|                  | 18               | 2066               | 38.5              | 3770               | 77.0              | 24                                   | 46.2                     | 92.4                     | 24                                   | 30.8                     | 61.6                     | 19.2                                 | 23.1                     | 46.2                     |
|                  | 19               | 1927               | 32.7              | 3684               | 65.5              | 24                                   | 39.3                     | 78.5                     | 24                                   | 26.2                     | 52.4                     | 19.2                                 | 19.6                     | 39.3                     |
| 20               | 1798             | 28.1               | 3452              | 56.1               | 24                | 33.7                                 | 67.3                     | 19.2                     | 22.4                                 | 44.9                     | 16                       | 16.8                                 | 33.7                     |                          |

| Deflection Limit | Wall Height [ft] | MAXIMUM LOADING    |                   |                    |                   | 25 PSF WIND LOAD SPACING & TRIBUTARY |                          |                          | 30 PSF WIND LOAD SPACING & TRIBUTARY |                          |                          | 40 PSF WIND LOAD SPACING & TRIBUTARY |                          |                          |
|------------------|------------------|--------------------|-------------------|--------------------|-------------------|--------------------------------------|--------------------------|--------------------------|--------------------------------------|--------------------------|--------------------------|--------------------------------------|--------------------------|--------------------------|
|                  |                  | Single Stud        |                   | Double Stud        |                   | Single Stud                          |                          | Double Stud              | Single Stud                          |                          | Double Stud              | Single Stud                          |                          | Double Stud              |
|                  |                  | Vertical Load [lb] | Wind Load [lb/ft] | Vertical Load [lb] | Wind Load [lb/ft] | Max Stud Spacing [in]                | Max Tributary Width [in] | Max Tributary Width [in] | Max Stud Spacing [in]                | Max Tributary Width [in] | Max Tributary Width [in] | Max Stud Spacing [in]                | Max Tributary Width [in] | Max Tributary Width [in] |
| L/360            | 10               | 4641               | 74.8              | 6469               | 149.6             | 24                                   | 35.9                     | 71.8                     | 24                                   | 29.9                     | 59.9                     | 19.2                                 | 22.4                     | 44.9                     |
|                  | 12               | 4641               | 43.3              | 6542               | 86.6              | 19.2                                 | 20.8                     | 41.6                     | 16                                   | 17.3                     | 34.6                     | 12                                   | 13.0                     | 26.0                     |
|                  | 14               | 4641               | 27.3              | 6495               | 54.5              | 12                                   | 13.1                     | 26.2                     | 8                                    | 10.9                     | 21.8                     | 8                                    | 8.2                      | 16.4                     |
|                  | 16               | 3933               | 18.3              | 6313               | 36.5              | 8                                    | 8.8                      | 17.5                     | 6                                    | 7.3                      | 14.6                     | 4                                    | 5.5                      | 11.0                     |
|                  | 17               | 3537               | 15.2              | 6163               | 30.5              | 6                                    | 7.3                      | 14.6                     | 6                                    | 6.1                      | 12.2                     | 4                                    | 4.6                      | 9.1                      |
|                  | 18               | 3198               | 12.8              | 5969               | 25.7              | 6                                    | 6.2                      | 12.3                     | 4                                    | 5.1                      | 10.3                     | --                                   | 3.8                      | 7.7                      |
|                  | 19               | 2906               | 10.9              | 5732               | 21.8              | 4                                    | 5.2                      | 10.5                     | 4                                    | 4.4                      | 8.7                      | --                                   | 3.3                      | 6.5                      |
| 20               | 2651             | 9.4                | 5234              | 18.7               | 4                 | 4.5                                  | 9.0                      | --                       | 3.7                                  | 7.5                      | --                       | 2.8                                  | 5.6                      |                          |
| L/240            | 10               | 4641               | 112.2             | 5638               | 224.5             | 24                                   | 53.9                     | 107.7                    | 24                                   | 44.9                     | 89.8                     | 24                                   | 33.7                     | 67.3                     |
|                  | 12               | 4641               | 65.0              | 5804               | 129.9             | 24                                   | 31.2                     | 62.4                     | 24                                   | 26.0                     | 52.0                     | 19.2                                 | 19.5                     | 39.0                     |
|                  | 14               | 4324               | 40.9              | 5800               | 81.8              | 19.2                                 | 19.6                     | 39.3                     | 16                                   | 16.4                     | 32.7                     | 12                                   | 12.3                     | 24.5                     |
|                  | 16               | 3490               | 27.4              | 5645               | 54.8              | 12                                   | 13.2                     | 26.3                     | 8                                    | 11.0                     | 21.9                     | 8                                    | 8.2                      | 16.4                     |
|                  | 17               | 3160               | 22.8              | 5512               | 45.7              | 8                                    | 11.0                     | 21.9                     | 8                                    | 9.1                      | 18.3                     | 6                                    | 6.9                      | 13.7                     |
|                  | 18               | 2873               | 19.2              | 5345               | 38.5              | 8                                    | 9.2                      | 18.5                     | 6                                    | 7.7                      | 15.4                     | 4                                    | 5.8                      | 11.5                     |
|                  | 19               | 2624               | 16.4              | 5142               | 32.7              | 6                                    | 7.9                      | 15.7                     | 6                                    | 6.5                      | 13.1                     | 4                                    | 4.9                      | 9.8                      |
| 20               | 2405             | 14.0               | 4721              | 28.1               | 6                 | 6.7                                  | 13.5                     | 4                        | 5.6                                  | 11.2                     | 4                        | 4.2                                  | 8.4                      |                          |
| L/180            | 10               | 4641               | 149.6             | 4744               | 299.3             | 24                                   | 71.8                     | 143.7                    | 24                                   | 59.9                     | 119.7                    | 24                                   | 44.9                     | 89.8                     |
|                  | 12               | 4620               | 86.6              | 5049               | 173.2             | 24                                   | 41.6                     | 83.1                     | 24                                   | 34.6                     | 69.3                     | 24                                   | 26.0                     | 52.0                     |
|                  | 14               | 3759               | 54.5              | 5122               | 109.1             | 24                                   | 26.2                     | 52.4                     | 19.2                                 | 21.8                     | 43.6                     | 16                                   | 16.4                     | 32.7                     |
|                  | 16               | 3097               | 36.5              | 5025               | 73.1              | 16                                   | 17.5                     | 35.1                     | 12                                   | 14.6                     | 29.2                     | 8                                    | 11.0                     | 21.9                     |
|                  | 17               | 2825               | 30.5              | 4921               | 60.9              | 12                                   | 14.6                     | 29.2                     | 12                                   | 12.2                     | 24.4                     | 8                                    | 9.1                      | 18.3                     |
|                  | 18               | 2586               | 25.7              | 4786               | 51.3              | 12                                   | 12.3                     | 24.6                     | 8                                    | 10.3                     | 20.5                     | 6                                    | 7.7                      | 15.4                     |
|                  | 19               | 2374               | 21.8              | 4624               | 43.6              | 8                                    | 10.5                     | 20.9                     | 8                                    | 8.7                      | 17.5                     | 6                                    | 6.5                      | 13.1                     |
| 20               | 2187             | 18.7               | 4265              | 37.4               | 8                 | 9.0                                  | 18.0                     | 6                        | 7.5                                  | 15.0                     | 4                        | 5.6                                  | 11.2                     |                          |
| L/120            | 10               | 3091               | 219.6             | 2758               | 422.3             | 24                                   | 107.7                    | 215.5                    | 24                                   | 89.8                     | 179.6                    | 24                                   | 65.9                     | 126.7                    |
|                  | 12               | 3006               | 129.9             | 3424               | 259.8             | 24                                   | 62.4                     | 124.7                    | 24                                   | 52.0                     | 103.9                    | 24                                   | 39.0                     | 77.9                     |
|                  | 14               | 2721               | 81.8              | 3760               | 163.6             | 24                                   | 39.3                     | 78.5                     | 24                                   | 32.7                     | 65.4                     | 24                                   | 24.5                     | 49.1                     |
|                  | 16               | 2380               | 54.8              | 3849               | 109.6             | 24                                   | 26.3                     | 52.6                     | 19.2                                 | 21.9                     | 43.8                     | 16                                   | 16.4                     | 32.9                     |
|                  | 17               | 2219               | 45.7              | 3826               | 91.4              | 19.2                                 | 21.9                     | 43.9                     | 16                                   | 18.3                     | 36.6                     | 12                                   | 13.7                     | 27.4                     |
|                  | 18               | 2066               | 38.5              | 3770               | 77.0              | 16                                   | 18.5                     | 37.0                     | 12                                   | 15.4                     | 30.8                     | 8                                    | 11.5                     | 23.1                     |
|                  | 19               | 1927               | 32.7              | 3684               | 65.5              | 12                                   | 15.7                     | 31.4                     | 12                                   | 13.1                     | 26.2                     | 8                                    | 9.8                      | 19.6                     |
| 20               | 1798             | 28.1               | 3452              | 56.1               | 12                | 13.5                                 | 26.9                     | 8                        | 11.2                                 | 22.4                     | 8                        | 8.4                                  | 16.8                     |                          |

**Notes**

- Wall stud analysis per 2005 National Design Specification (NDS) for Wood Construction.
- For 3-ply and 4-ply built up columns, multiply double stud table values by 1.5 and 2.0.
- Full depth blocking required at a maximum spacing of 8'-0" for single studs.
- Structural sheathing or structural siding installed on one side of wall.

- Double stud values assume unsupported lateral length of 7'-0".
- Table assumes wind load duration factor of 1.6 and vertical load duration factor of 1.0.
- Table assumes compression perpendicular to grain for plate of 450 psi.
- Vertical dead load may not exceed 50% of the total vertical load.
- Repetitive member increase for bending (1.04) applied to single studs only.
- Compression perpendicular to grain stress adjusted per NDS 3.10.4 for single studs only.

# Stud Load Tables

## VERSA-STUD® 1.7 2400 1½" x 7¼"

| Deflection Limit | Wall Height [ft] | MAXIMUM LOADING    |                   |                    |                   | 10 PSF WIND LOAD SPACING & TRIBUTARY |                          |                          | 15 PSF WIND LOAD SPACING & TRIBUTARY |                          |                          | 20 PSF WIND LOAD SPACING & TRIBUTARY |                          |                          |
|------------------|------------------|--------------------|-------------------|--------------------|-------------------|--------------------------------------|--------------------------|--------------------------|--------------------------------------|--------------------------|--------------------------|--------------------------------------|--------------------------|--------------------------|
|                  |                  | Single Stud        |                   | Double Stud        |                   | Single Stud                          |                          | Double Stud              | Single Stud                          |                          | Double Stud              | Single Stud                          |                          | Double Stud              |
|                  |                  | Vertical Load [lb] | Wind Load [lb/ft] | Vertical Load [lb] | Wind Load [lb/ft] | Max Stud Spacing [in]                | Max Tributary Width [in] | Max Tributary Width [in] | Max Stud Spacing [in]                | Max Tributary Width [in] | Max Tributary Width [in] | Max Stud Spacing [in]                | Max Tributary Width [in] | Max Tributary Width [in] |
| L/360            | 10               | 6117               | 171.4             | 8003               | 342.8             | 24                                   | 205.7                    | 411.3                    | 24                                   | 137.1                    | 274.2                    | 24                                   | 102.8                    | 205.7                    |
|                  | 12               | 6117               | 99.2              | 8319               | 198.4             | 24                                   | 119.0                    | 238.0                    | 24                                   | 79.3                     | 158.7                    | 24                                   | 59.5                     | 119.0                    |
|                  | 14               | 6117               | 62.5              | 8479               | 124.9             | 24                                   | 74.9                     | 149.9                    | 24                                   | 50.0                     | 99.9                     | 24                                   | 37.5                     | 74.9                     |
|                  | 16               | 6117               | 41.8              | 8536               | 83.7              | 24                                   | 50.2                     | 100.4                    | 24                                   | 33.5                     | 66.9                     | 24                                   | 25.1                     | 50.2                     |
|                  | 18               | 6117               | 29.4              | 8496               | 58.8              | 24                                   | 35.3                     | 70.5                     | 19.2                                 | 23.5                     | 47.0                     | 16                                   | 17.6                     | 35.3                     |
|                  | 20               | 5638               | 21.4              | 8357               | 42.8              | 24                                   | 25.7                     | 51.4                     | 16                                   | 17.1                     | 34.3                     | 12                                   | 12.9                     | 25.7                     |
|                  | 22               | 4781               | 16.1              | 8108               | 32.2              | 19.2                                 | 19.3                     | 38.6                     | 12                                   | 12.9                     | 25.8                     | 8                                    | 9.7                      | 19.3                     |
| 24               | 4104             | 12.4               | 7726              | 24.8               | 12                | 14.9                                 | 29.8                     | 8                        | 9.9                                  | 19.8                     | 6                        | 7.4                                  | 14.9                     |                          |
| L/240            | 10               | 6117               | 257.1             | 6488               | 514.2             | 24                                   | 308.5                    | 617.0                    | 24                                   | 205.7                    | 411.3                    | 24                                   | 154.2                    | 308.5                    |
|                  | 12               | 6117               | 148.8             | 7064               | 297.5             | 24                                   | 178.5                    | 357.1                    | 24                                   | 119.0                    | 238.0                    | 24                                   | 89.3                     | 178.5                    |
|                  | 14               | 6117               | 93.7              | 7379               | 187.4             | 24                                   | 112.4                    | 224.8                    | 24                                   | 74.9                     | 149.9                    | 24                                   | 56.2                     | 112.4                    |
|                  | 16               | 6117               | 62.8              | 7522               | 125.5             | 24                                   | 75.3                     | 150.6                    | 24                                   | 50.2                     | 100.4                    | 24                                   | 37.7                     | 75.3                     |
|                  | 18               | 5850               | 44.1              | 7534               | 88.2              | 24                                   | 52.9                     | 105.8                    | 24                                   | 35.3                     | 70.5                     | 24                                   | 26.4                     | 52.9                     |
|                  | 20               | 4957               | 32.1              | 7429               | 64.3              | 24                                   | 38.6                     | 77.1                     | 24                                   | 25.7                     | 51.4                     | 19.2                                 | 19.3                     | 38.6                     |
|                  | 22               | 4249               | 24.1              | 7210               | 48.3              | 24                                   | 29.0                     | 57.9                     | 19.2                                 | 19.3                     | 38.6                     | 12                                   | 14.5                     | 29.0                     |
| 24               | 3679             | 18.6               | 6889              | 37.2               | 19.2              | 22.3                                 | 44.6                     | 12                       | 14.9                                 | 29.8                     | 8                        | 11.2                                 | 22.3                     |                          |
| L/180            | 10               | 6117               | 342.8             | 4649               | 685.5             | 24                                   | 411.3                    | 822.6                    | 24                                   | 274.2                    | 548.4                    | 24                                   | 205.7                    | 411.3                    |
|                  | 12               | 6117               | 198.4             | 5673               | 396.7             | 24                                   | 238.0                    | 476.1                    | 24                                   | 158.7                    | 317.4                    | 24                                   | 119.0                    | 238.0                    |
|                  | 14               | 6117               | 124.9             | 6206               | 249.8             | 24                                   | 149.9                    | 299.8                    | 24                                   | 99.9                     | 199.9                    | 24                                   | 74.9                     | 149.9                    |
|                  | 16               | 5872               | 83.7              | 6478               | 167.4             | 24                                   | 100.4                    | 200.8                    | 24                                   | 66.9                     | 133.9                    | 24                                   | 50.2                     | 100.4                    |
|                  | 18               | 5037               | 58.8              | 6586               | 117.5             | 24                                   | 70.5                     | 141.1                    | 24                                   | 47.0                     | 94.0                     | 24                                   | 35.3                     | 70.5                     |
|                  | 20               | 4346               | 42.8              | 6548               | 85.7              | 24                                   | 51.4                     | 102.8                    | 24                                   | 34.3                     | 68.6                     | 24                                   | 25.7                     | 51.4                     |
|                  | 22               | 3774               | 32.2              | 6393               | 64.4              | 24                                   | 38.6                     | 77.3                     | 24                                   | 25.8                     | 51.5                     | 19.2                                 | 19.3                     | 38.6                     |
| 24               | 3304             | 24.8               | 6141              | 49.6               | 24                | 29.8                                 | 59.5                     | 19.2                     | 19.8                                 | 39.7                     | 12                       | 14.9                                 | 29.8                     |                          |
| L/120            | 10               | 6117               | 370.0             | 3940               | 711.5             | 24                                   | 444.0                    | 853.9                    | 24                                   | 296.0                    | 569.2                    | 24                                   | 222.0                    | 426.9                    |
|                  | 12               | 4895               | 256.9             | 3672               | 494.1             | 24                                   | 308.3                    | 593.0                    | 24                                   | 205.6                    | 395.3                    | 24                                   | 154.2                    | 296.5                    |
|                  | 14               | 3703               | 187.4             | 3447               | 363.0             | 24                                   | 224.8                    | 435.6                    | 24                                   | 149.9                    | 290.4                    | 24                                   | 112.4                    | 217.8                    |
|                  | 16               | 3746               | 125.5             | 4233               | 251.1             | 24                                   | 150.6                    | 301.3                    | 24                                   | 100.4                    | 200.8                    | 24                                   | 75.3                     | 150.6                    |
|                  | 18               | 3528               | 88.2              | 4645               | 176.3             | 24                                   | 105.8                    | 211.6                    | 24                                   | 70.5                     | 141.1                    | 24                                   | 52.9                     | 105.8                    |
|                  | 20               | 3223               | 64.3              | 4826               | 128.5             | 24                                   | 77.1                     | 154.2                    | 24                                   | 51.4                     | 102.8                    | 24                                   | 38.6                     | 77.1                     |
|                  | 22               | 2914               | 48.3              | 4862               | 96.6              | 24                                   | 57.9                     | 115.9                    | 24                                   | 38.6                     | 77.3                     | 24                                   | 29.0                     | 57.9                     |
| 24               | 2626             | 37.2               | 4774              | 74.4               | 24                | 44.6                                 | 89.3                     | 24                       | 29.8                                 | 59.5                     | 19.2                     | 22.3                                 | 44.6                     |                          |

| Deflection Limit | Wall Height [ft] | MAXIMUM LOADING    |                   |                    |                   | 25 PSF WIND LOAD SPACING & TRIBUTARY |                          |                          | 30 PSF WIND LOAD SPACING & TRIBUTARY |                          |                          | 40 PSF WIND LOAD SPACING & TRIBUTARY |                          |                          |
|------------------|------------------|--------------------|-------------------|--------------------|-------------------|--------------------------------------|--------------------------|--------------------------|--------------------------------------|--------------------------|--------------------------|--------------------------------------|--------------------------|--------------------------|
|                  |                  | Single Stud        |                   | Double Stud        |                   | Single Stud                          |                          | Double Stud              | Single Stud                          |                          | Double Stud              | Single Stud                          |                          | Double Stud              |
|                  |                  | Vertical Load [lb] | Wind Load [lb/ft] | Vertical Load [lb] | Wind Load [lb/ft] | Max Stud Spacing [in]                | Max Tributary Width [in] | Max Tributary Width [in] | Max Stud Spacing [in]                | Max Tributary Width [in] | Max Tributary Width [in] | Max Stud Spacing [in]                | Max Tributary Width [in] | Max Tributary Width [in] |
| L/360            | 10               | 6117               | 171.4             | 8003               | 342.8             | 24                                   | 82.3                     | 164.5                    | 24                                   | 68.6                     | 137.1                    | 24                                   | 51.4                     | 102.8                    |
|                  | 12               | 6117               | 99.2              | 8319               | 198.4             | 24                                   | 47.6                     | 95.2                     | 24                                   | 39.7                     | 79.3                     | 24                                   | 29.8                     | 59.5                     |
|                  | 14               | 6117               | 62.5              | 8479               | 124.9             | 24                                   | 30.0                     | 60.0                     | 24                                   | 25.0                     | 50.0                     | 16                                   | 18.7                     | 37.5                     |
|                  | 16               | 6117               | 41.8              | 8536               | 83.7              | 19.2                                 | 20.1                     | 40.2                     | 16                                   | 16.7                     | 33.5                     | 12                                   | 12.6                     | 25.1                     |
|                  | 18               | 6117               | 29.4              | 8496               | 58.8              | 12                                   | 14.1                     | 28.2                     | 8                                    | 11.8                     | 23.5                     | 8                                    | 8.8                      | 17.6                     |
|                  | 20               | 5638               | 21.4              | 8357               | 42.8              | 8                                    | 10.3                     | 20.6                     | 8                                    | 8.6                      | 17.1                     | 6                                    | 6.4                      | 12.9                     |
|                  | 22               | 4781               | 16.1              | 8108               | 32.2              | 6                                    | 7.7                      | 15.5                     | 6                                    | 6.4                      | 12.9                     | 4                                    | 4.8                      | 9.7                      |
| 24               | 4104             | 12.4               | 7726              | 24.8               | 4                 | 6.0                                  | 11.9                     | 4                        | 5.0                                  | 9.9                      | --                       | 3.7                                  | 7.4                      |                          |
| L/240            | 10               | 6117               | 257.1             | 6488               | 514.2             | 24                                   | 123.4                    | 246.8                    | 24                                   | 102.8                    | 205.7                    | 24                                   | 77.1                     | 154.2                    |
|                  | 12               | 6117               | 148.8             | 7064               | 297.5             | 24                                   | 71.4                     | 142.8                    | 24                                   | 59.5                     | 119.0                    | 24                                   | 44.6                     | 89.3                     |
|                  | 14               | 6117               | 93.7              | 7379               | 187.4             | 24                                   | 45.0                     | 89.9                     | 24                                   | 37.5                     | 74.9                     | 24                                   | 28.1                     | 56.2                     |
|                  | 16               | 6117               | 62.8              | 7522               | 125.5             | 24                                   | 30.1                     | 60.3                     | 24                                   | 25.1                     | 50.2                     | 16                                   | 18.8                     | 37.7                     |
|                  | 18               | 5850               | 44.1              | 7534               | 88.2              | 19.2                                 | 21.2                     | 42.3                     | 16                                   | 17.6                     | 35.3                     | 12                                   | 13.2                     | 26.4                     |
|                  | 20               | 4957               | 32.1              | 7429               | 64.3              | 12                                   | 15.4                     | 30.8                     | 12                                   | 12.9                     | 25.7                     | 8                                    | 9.6                      | 19.3                     |
|                  | 22               | 4249               | 24.1              | 7210               | 48.3              | 8                                    | 11.6                     | 23.2                     | 8                                    | 9.7                      | 19.3                     | 6                                    | 7.2                      | 14.5                     |
| 24               | 3679             | 18.6               | 6889              | 37.2               | 8                 | 8.9                                  | 17.9                     | 6                        | 7.4                                  | 14.9                     | 4                        | 5.6                                  | 11.2                     |                          |
| L/180            | 10               | 6117               | 342.8             | 4649               | 685.5             | 24                                   | 164.5                    | 329.1                    | 24                                   | 137.1                    | 274.2                    | 24                                   | 102.8                    | 205.7                    |
|                  | 12               | 6117               | 198.4             | 5673               | 396.7             | 24                                   | 95.2                     | 190.4                    | 24                                   | 79.3                     | 158.7                    | 24                                   | 59.5                     | 119.0                    |
|                  | 14               | 6117               | 124.9             | 6206               | 249.8             | 24                                   | 60.0                     | 119.9                    | 24                                   | 50.0                     | 99.9                     | 24                                   | 37.5                     | 74.9                     |
|                  | 16               | 5872               | 83.7              | 6478               | 167.4             | 24                                   | 40.2                     | 80.3                     | 24                                   | 33.5                     | 66.9                     | 24                                   | 25.1                     | 50.2                     |
|                  | 18               | 5037               | 58.8              | 6586               | 117.5             | 24                                   | 28.2                     | 56.4                     | 19.2                                 | 23.5                     | 47.0                     | 16                                   | 17.6                     | 35.3                     |
|                  | 20               | 4346               | 42.8              | 6548               | 85.7              | 19.2                                 | 20.6                     | 41.1                     | 16                                   | 17.1                     | 34.3                     | 12                                   | 12.9                     | 25.7                     |
|                  | 22               | 3774               | 32.2              | 6393               | 64.4              | 12                                   | 15.5                     | 30.9                     | 12                                   | 12.9                     | 25.8                     | 8                                    | 9.7                      | 19.3                     |
| 24               | 3304             | 24.8               | 6141              | 49.6               | 8                 | 11.9                                 | 23.8                     | 8                        | 9.9                                  | 19.8                     | 6                        | 7.4                                  | 14.9                     |                          |
| L/120            | 10               | 6117               | 370.0             | 3940               | 711.5             | 24                                   | 177.6                    | 341.5                    | 24                                   | 148.0                    | 284.6                    | 24                                   | 111.0                    | 213.5                    |
|                  | 12               | 4895               | 256.9             | 3672               | 494.1             | 24                                   | 123.3                    | 237.2                    | 24                                   | 102.8                    | 197.7                    | 24                                   | 77.1                     | 148.2                    |
|                  | 14               | 3703               | 187.4             | 3447               | 363.0             | 24                                   | 89.9                     | 174.3                    | 24                                   | 74.9                     | 145.2                    | 24                                   | 56.2                     | 108.9                    |
|                  | 16               | 3746               | 125.5             | 4233               | 251.1             | 24                                   | 60.3                     | 120.5                    | 24                                   | 50.2                     | 100.4                    | 24                                   | 37.7                     | 75.3                     |
|                  | 18               | 3528               | 88.2              | 4645               | 176.3             | 24                                   | 42.3                     | 84.6                     | 24                                   | 35.3                     | 70.5                     | 24                                   | 26.4                     | 52.9                     |
|                  | 20               | 3223               | 64.3              | 4826               | 128.5             | 24                                   | 30.8                     | 61.7                     | 24                                   | 25.7                     | 51.4                     | 19.2                                 | 19.3                     | 38.6                     |
|                  | 22               | 2914               | 48.3              | 4862               | 96.6              | 19.2                                 | 23.2                     | 46.4                     | 19.2                                 | 19.3                     | 38.6                     | 12                                   | 14.5                     | 29.0                     |
| 24               | 2626             | 37.2               | 4774              | 74.4               | 16                | 17.9                                 | 35.7                     | 12                       | 14.9                                 | 29.8                     | 8                        | 11.2                                 | 22.3                     |                          |

**Notes**

- Wall stud analysis per 2005 National Design Specification (NDS) for Wood Construction.
- For 3-ply and 4-ply built up columns, multiply double stud table values by 1.5 and 2.0.
- Full depth blocking required at a maximum spacing of 8'-0" for single studs.
- Structural sheathing or structural siding installed on one side of wall.

- Double stud values assume unsupported lateral length of 7'-0".
- Table assumes wind load duration factor of 1.6 and vertical load duration factor of 1.0.
- Table assumes compression perpendicular to grain for plate of 450 psi.
- Vertical dead load may not exceed 50% of the total vertical load.
- Repetitive member increase for bending (1.04) applied to single studs only.
- Compression perpendicular to grain stress adjusted per NDS 3.10.4 for single studs only.

**Multiple-Ply Stud Connections**

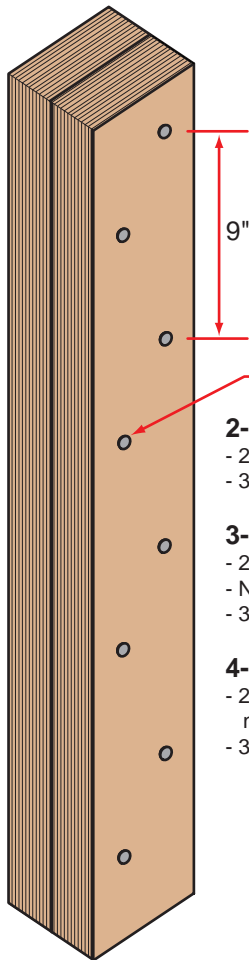

- Stagger rows
- 2-Ply 1½" Connection**  
 - 2 rows 10d (min) nails @ 9" o.c.  
 - 3 rows for 9¼" and greater studs
- 3-Ply 1½" Connection**  
 - 2 rows 10d (min) nails @ 9" o.c.  
 - Nail from each side  
 - 3 rows for 9¼" and greater studs
- 4-Ply 1½" Connection**  
 - 2 rows 10d (min) nails @ 9" o.c.,  
 nailed from each ply to each ply  
 - 3 rows for 9¼" and greater studs

**Header to Column**

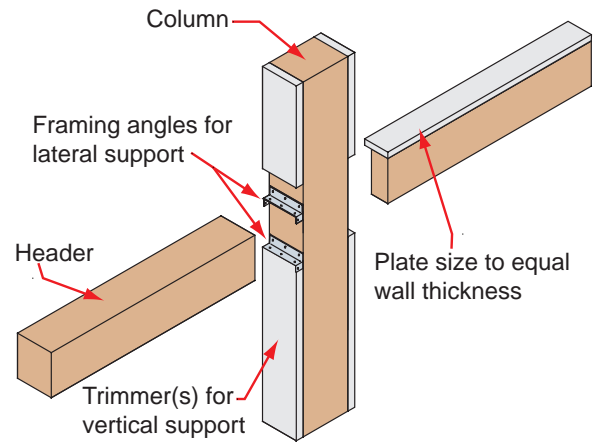

**Column to Bottom Plate**

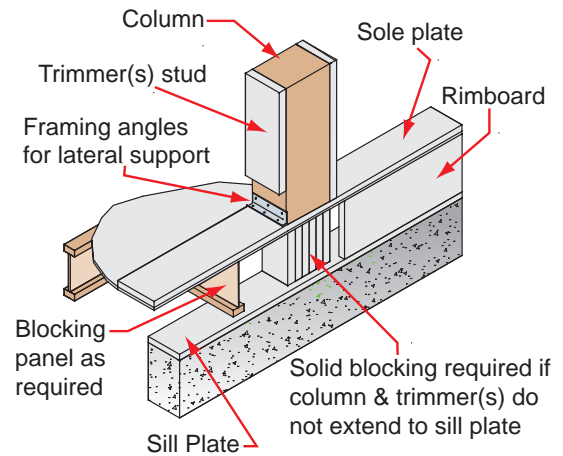

**3½" Studs - 24" o.c.**

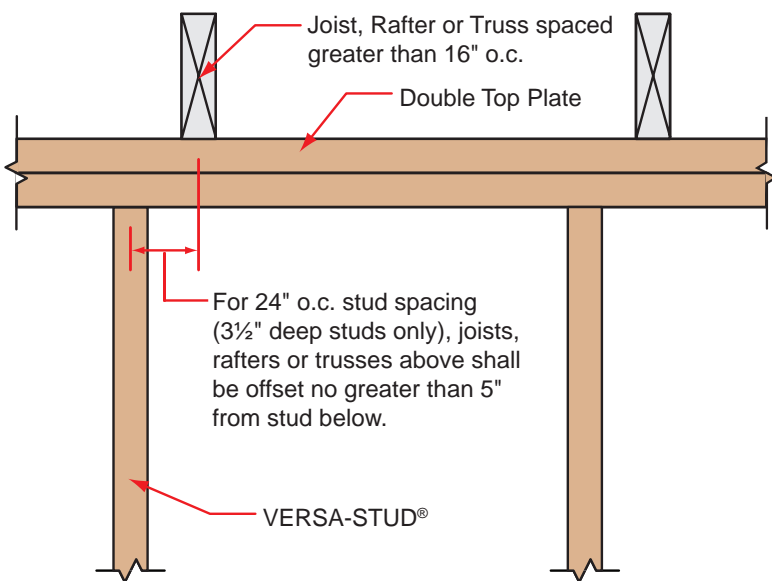

**Column to Top Plate**

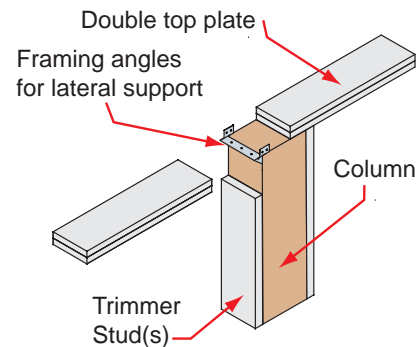

# VERSA-LAM® 1.7 2650 Exterior Wall Column Table

| Deflection Limit | Column Height [ft] | 3½" Thick Wall     |                   |                    |                   |                    |                   | 5½" Thick Wall     |                   |                    |                   |                    |                   | 7¼" Thick Wall     |                   |                    |                   |                    |                   |        |
|------------------|--------------------|--------------------|-------------------|--------------------|-------------------|--------------------|-------------------|--------------------|-------------------|--------------------|-------------------|--------------------|-------------------|--------------------|-------------------|--------------------|-------------------|--------------------|-------------------|--------|
|                  |                    | 3½" x 3½"          |                   | 5¼" x 3½"          |                   | 7" x 3½"           |                   | 3½" x 5¼"          |                   | 5¼" x 5¼"          |                   | 7" x 5¼"           |                   | 3½" x 7"           |                   | 5¼" x 7"           |                   | 7" x 7"            |                   |        |
|                  |                    | Vertical Load [lb] | Wind Load [lb/ft] | Vertical Load [lb] | Wind Load [lb/ft] | Vertical Load [lb] | Wind Load [lb/ft] | Vertical Load [lb] | Wind Load [lb/ft] | Vertical Load [lb] | Wind Load [lb/ft] | Vertical Load [lb] | Wind Load [lb/ft] | Vertical Load [lb] | Wind Load [lb/ft] | Vertical Load [lb] | Wind Load [lb/ft] | Vertical Load [lb] | Wind Load [lb/ft] |        |
| L/360            | 7                  | 5513               | 131.2             | 8269               | 196.8             | 11025              | 262.3             | 8269               | 442.7             | 12403              | 664.1             | 16538              | 885.4             | 11025              | 1049.4            | 16538              | 1574.1            | 22050              | 2098.8            |        |
|                  | 8                  | 5513               | 87.9              | 8269               | 131.8             | 11025              | 175.8             | 8269               | 296.6             | 12403              | 444.9             | 16538              | 593.2             | 11025              | 703.0             | 16538              | 1054.5            | 22050              | 1406.0            |        |
|                  | 9                  | 5513               | 61.7              | 8269               | 92.6              | 11025              | 123.4             | 8269               | 208.3             | 12403              | 312.4             | 16538              | 416.6             | 11025              | 493.7             | 16538              | 740.6             | 22050              | 987.5             |        |
|                  | 10                 | 5513               | 45.0              | 8269               | 67.5              | 11025              | 90.0              | 8269               | 151.8             | 12403              | 227.8             | 16538              | 303.7             | 11025              | 359.9             | 16538              | 539.9             | 22050              | 719.9             |        |
|                  | 11                 | 5113               | 33.8              | 7670               | 50.7              | 10226              | 67.6              | 8269               | 114.1             | 12403              | 171.1             | 16538              | 228.2             | 11025              | 270.4             | 16538              | 405.6             | 22050              | 540.9             |        |
|                  | 12                 | 4383               | 26.0              | 6575               | 39.1              | 8765               | 52.1              | 8269               | 87.9              | 12403              | 131.8             | 16538              | 175.8             | 11025              | 208.3             | 16538              | 312.4             | 22050              | 416.6             |        |
|                  | 13                 | 3799               | 20.5              | 5699               | 30.7              | 7597               | 41.0              | 8269               | 69.1              | 12403              | 103.7             | 16538              | 138.2             | 11025              | 163.8             | 16538              | 245.7             | 22050              | 327.7             |        |
|                  | 14                 | 3324               | 16.4              | 4987               | 24.6              | 6648               | 32.8              | 8269               | 55.3              | 12403              | 83.0              | 16538              | 110.7             | 11025              | 131.2             | 16538              | 196.8             | 22050              | 262.3             |        |
|                  | 15                 |                    |                   |                    |                   |                    |                   | 8269               | 45.0              | 12403              | 67.5              | 16538              | 90.0              | 11025              | 106.6             | 16538              | 160.0             | 22050              | 213.3             |        |
|                  | 16                 |                    |                   |                    |                   |                    |                   | 8195               | 37.1              | 12016              | 55.6              | 16021              | 74.1              | 11025              | 87.9              | 16538              | 131.8             | 22050              | 175.8             |        |
|                  | 17                 |                    |                   |                    |                   |                    |                   | 7362               | 30.9              | 10802              | 46.4              | 14405              | 61.8              | 11025              | 73.3              | 16538              | 109.9             | 22050              | 146.5             |        |
|                  | 18                 |                    |                   |                    |                   |                    |                   | 6649               | 26.0              | 9764               | 39.1              | 13022              | 52.1              | 11025              | 61.7              | 16538              | 92.6              | 22050              | 123.4             |        |
|                  | 19                 |                    |                   |                    |                   |                    |                   | 6034               | 22.1              | 8869               | 33.2              | 11829              | 44.3              | 11025              | 52.5              | 16538              | 78.7              | 22050              | 105.0             |        |
|                  | 20                 |                    |                   |                    |                   |                    |                   | 5500               | 19.0              | 8096               | 28.5              | 10793              | 38.0              | 11025              | 45.0              | 16538              | 67.5              | 22050              | 90.0              |        |
|                  | 21                 |                    |                   |                    |                   |                    |                   | 5036               | 16.4              | 7416               | 24.6              | 9887               | 32.8              | 11025              | 38.9              | 16538              | 58.3              | 21781              | 77.7              |        |
|                  | 22                 |                    |                   |                    |                   |                    |                   |                    |                   |                    |                   |                    |                   | 10276              | 33.8              | 15422              | 50.7              | 20090              | 67.6              |        |
|                  | 23                 |                    |                   |                    |                   |                    |                   |                    |                   |                    |                   |                    |                   | 9500               | 29.6              | 14249              | 44.4              | 18585              | 59.2              |        |
|                  | 24                 |                    |                   |                    |                   |                    |                   |                    |                   |                    |                   |                    |                   | 8807               | 26.0              | 13209              | 39.1              | 17242              | 52.1              |        |
|                  | L/240              | 7                  | 5513              | 196.8              | 8269              | 295.1              | 11025             | 393.5              | 8269              | 664.1              | 12403             | 996.1              | 16538             | 1328.1             | 11025             | 1574.1             | 16538             | 2361.1             | 22050             | 3148.1 |
|                  |                    | 8                  | 5513              | 131.8              | 8269              | 197.7              | 11025             | 263.6              | 8269              | 444.9              | 12403             | 667.3              | 16538             | 889.7              | 11025             | 1054.5             | 16538             | 1581.8             | 22050             | 2109.0 |
|                  |                    | 9                  | 5513              | 92.6               | 8269              | 138.9              | 11025             | 185.2              | 8269              | 312.4              | 12403             | 468.7              | 16538             | 624.9              | 11025             | 740.6              | 16538             | 1110.9             | 22050             | 1481.2 |
|                  |                    | 10                 | 5359              | 67.5               | 8037              | 101.2              | 10718             | 135.0              | 8269              | 227.8              | 12403             | 341.7              | 16538             | 455.5              | 11025             | 539.9              | 16538             | 809.9              | 22050             | 1079.8 |
|                  |                    | 11                 | 4581              | 50.7               | 6870              | 76.1               | 9162              | 101.4              | 8269              | 171.1              | 12403             | 256.7              | 16538             | 342.3              | 11025             | 405.6              | 16538             | 608.5              | 22050             | 811.3  |
|                  |                    | 12                 | 3959              | 39.1               | 5937              | 58.6               | 7917              | 78.1               | 8269              | 131.8              | 12403             | 197.7              | 16538             | 263.6              | 11025             | 312.4              | 16538             | 468.7              | 22050             | 624.9  |
| 13               |                    | 3455               | 30.7              | 5180               | 46.1              | 6908               | 61.4              | 8269               | 103.7             | 12403              | 155.5             | 16538              | 207.3             | 11025              | 245.7             | 16538              | 368.6             | 22050              | 491.5             |        |
| 14               |                    | 3040               | 24.6              | 4559               | 36.9              | 6080               | 49.2              | 8269               | 83.0              | 12403              | 124.5             | 16538              | 166.0             | 11025              | 196.8             | 16538              | 295.1             | 22050              | 393.5             |        |
| 15               |                    |                    |                   |                    |                   |                    |                   | 8191               | 67.5              | 11861              | 101.2             | 15814              | 135.0             | 11025              | 160.0             | 16538              | 240.0             | 22050              | 319.9             |        |
| 16               |                    |                    |                   |                    |                   |                    |                   | 7357               | 55.6              | 10680              | 83.4              | 14240              | 111.2             | 11025              | 131.8             | 16538              | 197.7             | 22050              | 263.6             |        |
| 17               |                    |                    |                   |                    |                   |                    |                   | 6646               | 46.4              | 9664               | 69.5              | 12886              | 92.7              | 11025              | 109.9             | 16538              | 164.8             | 22050              | 219.8             |        |
| 18               |                    |                    |                   |                    |                   |                    |                   | 6033               | 39.1              | 8785               | 58.6              | 11714              | 78.1              | 11025              | 92.6              | 16538              | 138.9             | 22050              | 185.2             |        |
| 19               |                    |                    |                   |                    |                   |                    |                   | 5496               | 33.2              | 8019               | 49.8              | 10693              | 66.4              | 11025              | 78.7              | 16538              | 118.1             | 22050              | 157.4             |        |
| 20               |                    |                    |                   |                    |                   |                    |                   | 5035               | 28.5              | 7348               | 42.7              | 9799               | 56.9              | 10800              | 67.5              | 16198              | 101.2             | 20830              | 135.0             |        |
| 21               |                    |                    |                   |                    |                   |                    |                   | 4623               | 24.6              | 6758               | 36.9              | 9012               | 49.2              | 9971               | 58.3              | 14952              | 87.4              | 19258              | 116.6             |        |
| 22               |                    |                    |                   |                    |                   |                    |                   |                    |                   |                    |                   |                    |                   | 9227               | 50.7              | 13844              | 76.1              | 17853              | 101.4             |        |
| 23               |                    |                    |                   |                    |                   |                    |                   |                    |                   |                    |                   |                    |                   | 8566               | 44.4              | 12850              | 66.6              | 16594              | 88.7              |        |
| 24               |                    |                    |                   |                    |                   |                    |                   |                    |                   |                    |                   |                    |                   | 7966               | 39.1              | 11959              | 58.6              | 15461              | 78.1              |        |
| L/180            |                    | 7                  | 5513              | 262.3              | 8269              | 393.5              | 11025             | 524.7              | 8269              | 885.4              | 12403             | 1328.1             | 16538             | 1770.8             | 11025             | 1697.2             | 16538             | 2598.3             | 22050             | 3171.0 |
|                  |                    | 8                  | 5513              | 175.8              | 8269              | 263.6              | 11025             | 351.5              | 8269              | 593.2              | 12403             | 889.7              | 16538             | 1186.3             | 11025             | 1299.4             | 16538             | 1989.4             | 22050             | 2427.8 |
|                  |                    | 9                  | 5513              | 123.4              | 8269              | 185.2              | 11025             | 246.9              | 8269              | 416.6              | 12403             | 624.9              | 16538             | 833.2              | 11025             | 987.5              | 16538             | 1481.2             | 22050             | 1918.3 |
|                  |                    | 10                 | 4751              | 90.0               | 7125              | 135.0              | 9501              | 180.0              | 8269              | 303.7              | 12403             | 455.5              | 16538             | 607.4              | 11025             | 719.9              | 16538             | 1079.8             | 22050             | 1439.8 |
|                  |                    | 11                 | 4109              | 67.6               | 6163              | 101.4              | 8217              | 135.2              | 8269              | 228.2              | 12403             | 342.3              | 16538             | 456.3              | 11025             | 540.9              | 16538             | 811.3              | 22050             | 1081.7 |
|                  |                    | 12                 | 3584              | 52.1               | 5375              | 78.1               | 7168              | 104.1              | 8269              | 175.8              | 12403             | 263.6              | 16538             | 351.5              | 11025             | 416.6              | 16538             | 624.9              | 22050             | 833.2  |
|                  | 13                 | 3151               | 41.0              | 4726               | 61.4              | 6302               | 81.9              | 8269               | 138.2             | 12403              | 207.3             | 16538              | 276.5             | 11025              | 327.7             | 16538              | 491.5             | 22050              | 655.3             |        |
|                  | 14                 | 2791               | 32.8              | 4185               | 49.2              | 5581               | 65.6              | 8111               | 110.7             | 11540              | 166.0             | 15387              | 221.4             | 11025              | 262.3             | 16538              | 393.5             | 22050              | 524.7             |        |
|                  | 15                 |                    |                   |                    |                   |                    |                   | 7310               | 90.0              | 10448              | 135.0             | 13930              | 180.0             | 11025              | 213.3             | 16538              | 319.9             | 22050              | 426.6             |        |
|                  | 16                 |                    |                   |                    |                   |                    |                   | 6616               | 74.1              | 9491               | 111.2             | 12655              | 148.3             | 11025              | 175.8             | 16538              | 263.6             | 22050              | 351.5             |        |
|                  | 17                 |                    |                   |                    |                   |                    |                   | 6017               | 61.8              | 8653               | 92.7              | 11537              | 123.6             | 11025              | 146.5             | 16538              | 219.8             | 22050              | 293.0             |        |
|                  | 18                 |                    |                   |                    |                   |                    |                   | 5490               | 52.1              | 7916               | 78.1              | 10555              | 104.1             | 11025              | 123.4             | 16538              | 185.2             | 21172              | 246.9             |        |
|                  | 19                 |                    |                   |                    |                   |                    |                   | 5029               | 44.3              | 7267               | 66.4              | 9689               | 88.6              | 10366              | 105.0             | 15548              | 157.4             | 19647              | 209.9             |        |
|                  | 20                 |                    |                   |                    |                   |                    |                   | 4622               | 38.0              | 6692               | 56.9              | 8922               | 75.9              | 9599               | 90.0              | 14405              | 135.0             | 18261              | 180.0             |        |
|                  | 21                 |                    |                   |                    |                   |                    |                   | 4261               | 32.8              | 6181               | 49.2              | 8241               | 65.6              | 8916               | 77.7              | 13375              | 116.6             | 17004              | 155.5             |        |
|                  | 22                 |                    |                   |                    |                   |                    |                   |                    |                   |                    |                   |                    |                   | 8292               | 67.6              | 12446              | 101.4             | 15862              | 135.2             |        |
|                  | 23                 |                    |                   |                    |                   |                    |                   |                    |                   |                    |                   |                    |                   | 7737               | 59.2              | 11607              | 88.7              | 14825              | 118.3             |        |
|                  | 24                 |                    |                   |                    |                   |                    |                   |                    |                   |                    |                   |                    |                   | 7231               | 52.1              | 10847              | 78.1              | 13882              | 104.1             |        |
|                  | L/120              | 7                  | 4634              | 393.5              | 6936              | 590.3              | 9266              | 787.0              | 8269              | 996.9              | 12403             | 1381.2             | 16538             | 1841.6             | 11025             | 1697.2             | 16538             | 2598.3             | 22050             | 3171.0 |
|                  |                    | 8                  | 4435              | 263.6              | 6645              | 395.4              | 8869              | 527.3              | 8269              | 763.2              | 12403             | 1057.5             | 16538             | 1410.0             | 11025             | 1299.4             | 16538             | 1989.4             | 22050             | 2427.8 |
|                  |                    | 9                  | 4056              | 185.2              | 6078              | 277.7              | 8104              | 370.3              | 8133              | 603.1              | 11596             | 835.6              | 15485             | 1114.1             | 11025             | 1026.7             | 16538             | 1571.8             | 22050             | 1918.3 |
|                  |                    | 10                 | 3643              | 135.0              | 5462              | 202.5              | 7282              | 270.0              | 7719              | 455.5              | 9429              | 676.8              | 12587             | 902.4              | 11025             | 831.6              | 16538             | 1273.2             | 22050             | 1553.8 |
|                  |                    | 11                 | 3257              | 101.4              | 4883              | 152.1              | 6511              | 202.8              | 7533              | 342.3              | 9520              | 513.4              | 12715             | 684.5              | 11025             | 687.3              | 16538             | 1052.2             | 22050             | 1284.1 |
|                  |                    | 12                 | 2912              | 78.1               | 4366              | 117.2              | 5822              | 156.2              | 7135              | 263.6              | 9344              | 395.4              | 12471             | 527.3              | 10342             | 577.5              | 15906             | 884.2              | 20647             | 1079.0 |
| 13               |                    | 2610               | 61.4              | 3914               | 92.2              | 5218               | 122.9             | 6662               | 207.3             | 8920               | 311.0             | 11893              | 414.7             | 9560               | 491.5             | 14306              | 737.2             | 17619              | 919.4             |        |
| 14               |                    | 2347               | 49.2              | 3520               | 73.8              | 4693               | 98.4              | 6181               | 166.0             | 8402               | 249.0             | 11204              | 332.0             | 9654               | 393.5             | 14483              | 590.3             | 15542              | 787.0             |        |
| 15               |                    |                    |                   |                    |                   |                    |                   | 5717               | 135.0             | 7860               | 202.5             | 10481              | 270.0             | 9471               | 319.9             | 14185              | 479.9             | 15894              | 639.9             |        |
| 16               |                    |                    |                   |                    |                   |                    |                   | 5279               | 111.2             | 7327               | 166.8             | 9771               | 222.4             | 9137               | 263.6             | 13705              | 395.4             | 15767              | 527.3             |        |
| 17               |                    |                    |                   |                    |                   |                    |                   | 4879               | 92.7              | 6820               | 139.1             | 9097               | 185.4             | 8731               | 219.8             | 13089              | 329.7             | 15368              | 439.6             |        |
| 18               |                    |                    |                   |                    |                   |                    |                   | 4520               | 78.1              | 6348               | 117.2             | 8468               | 156.2             | 8294               | 185.2             | 12428              | 277.7             | 14818              | 370.3             |        |
| 19               |                    |                    |                   |                    |                   |                    |                   | 4190               | 66.4              | 5912               | 99.6              | 7888               | 132.8             | 7851               | 157.4             | 11780              | 236.1             | 14192              | 314.9             |        |
| 20               |                    |                    |                   |                    |                   |                    |                   | 3891               | 56.9              | 5512               | 85.4              | 7355               | 113.9             | 7422               | 135.0             | 11133              | 202.5             | 13536              | 270.0             |        |
| 21               |                    |                    |                   |                    |                   |                    |                   | 3620               | 49.2              | 5150               | 73.8              | 6867               | 98.4              | 7000               | 116.6             | 10513              | 174.9             | 12877              | 233.2             |        |
| 22               |                    |                    |                   |                    |                   |                    |                   |                    |                   |                    |                   |                    |                   | 6615               | 101.4             | 9926               | 152.1             | 12233              | 202.8             |        |
| 23               |                    |                    |                   |                    |                   |                    |                   |                    |                   |                    |                   |                    |                   | 6251               | 88.7              | 9373               | 133.1             | 11612              | 177.5             |        |
| 24               |                    |                    |                   |                    |                   |                    |                   |                    |                   |                    |                   |                    |                   | 5906               | 78.1              | 8856               | 117.2             | 11033              | 156.2             |        |

**Notes**

- Column analysis per 2005 National Design Specification (NDS) for Wood Construction.
- Allowable loads are based upon one-piece (solid) columns used in dry service conditions.
- Install columns with depth

## VERSA-STUD® 1.7 2400 Nail Design Values

| Nail Type  | Nail Diameter | Nail Length | Lateral Capacity [lb] | Lateral End Grain Capacity [lb] | Lateral Toe-Nail Capacity [lb] |
|------------|---------------|-------------|-----------------------|---------------------------------|--------------------------------|
| 8d box     | 0.113"        | 2.5"        | 116                   | 78                              | 96                             |
| 8d common  | 0.131"        | 2.5"        | 143                   | 96                              | 119                            |
| 10d box    | 0.128"        | 3"          | 148                   | 99                              | 123                            |
| 10d common | 0.148"        | 3"          | 188                   | 126                             | 156                            |
| 12d box    | 0.128"        | 3.25"       | 148                   | 99                              | 123                            |
| 12d common | 0.148"        | 3.25"       | 188                   | 126                             | 156                            |
| 16d box    | 0.135"        | 3.5"        | 165                   | 111                             | 137                            |
| 16d sinker | 0.148"        | 3.25"       | 188                   | 126                             | 156                            |
| 16d common | 0.162"        | 3.5"        | 225                   | 151                             | 187                            |

**Notes**

- Nail values per 2005 National Design Specification (NDS) for Wood Construction.
- Nail values based upon a load duration factor of 1.60 and an equivalent specific gravity of 0.5.

- Lateral capacities based upon a side-member thickness of 1½".
- For end grain connections, a reduction factor of 0.67 is applied (NDS 11.5.2).
- For toe-nailed connections, a reduction factor of 0.83 is applied (NDS 11.5.4).

## Wall Connectors

## FRAMING ANGLES

## Simpson Strong-Tie

| Model No. | Length | Stud Size | Nailing       | Allowable Load [lb] |     |
|-----------|--------|-----------|---------------|---------------------|-----|
|           |        |           |               | F1                  | F2  |
| A23       | 2¾"    | 3½"       | (8) 10d x 1½" | 565                 | 585 |
| A34       | 2½"    | 3½"       | (8) 8d x 1½"  | 365                 | 280 |
| L30       | 3"     | 3½"       | (4) 10d       | 240                 | 240 |
| LS30      | 3¾"    | 3½"       | (6) 10d       | 395                 | -   |
| L50       | 5"     | 5½"       | (6) 10d       | 445                 | 445 |
| LS50      | 4⅞"    | 5½"       | (8) 10d       | 560                 | -   |
| L70       | 7"     | 7¼"       | (8) 10d       | 565                 | 565 |
| LS70      | 6¾"    | 7¼"       | (10) 10d      | 665                 | -   |
| L70       | 7"     | 7¼"       | (8) 10d       | 565                 | 565 |

## USP Structural Connectors

| Model No. | Length                            | Stud Size | Nailing       | Allowable Load [lb] |     |
|-----------|-----------------------------------|-----------|---------------|---------------------|-----|
|           |                                   |           |               | F1                  | F2  |
| A3        | 2¾"                               | 3½"       | (8) 10d x 1½" | 590                 | 600 |
| AC3       | 2⅞"                               | 3½"       | (4) 10d x 1½" | 285                 | 320 |
| MP3       | 3¾"                               | 3½"       | (6) 10d       | 485                 | -   |
| AC5       | 4⅞"                               | 5½"       | (6) 10d x 1½" | 555                 | 555 |
| MP5       | 4⅝"                               | 5½"       | (8) 10d       | 730                 | -   |
| AC7       | 6 <sup>15</sup> / <sub>16</sub> " | 7¼"       | (8) 10d       | 740                 | 740 |
| L70       | 5⅞"                               | 7¼"       | (10) 10d      | 910                 | -   |

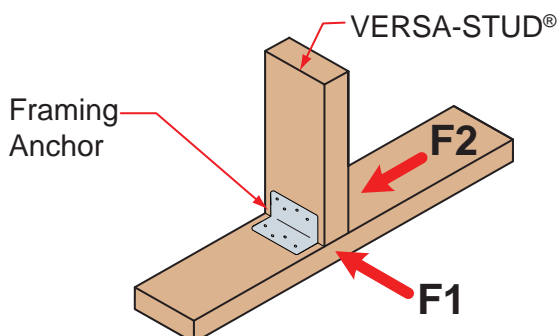

## STUD/PLATE TIES

## Simpson Strong-Tie

| Model No. | Nailing        | Uplift [lb] |
|-----------|----------------|-------------|
| RSP4      | (8) 8d x 1½"   | 315         |
| SSP       | (7) 10d x 1½"  | 350         |
| DSP       | (14) 10d x 1½" | 775         |
| SP1       | (10) 10d       | 585         |
| SP2       | (12) 10d       | 1065        |

## USP Structural Connectors

| Model No. | Nailing        | Uplift [lb] |
|-----------|----------------|-------------|
| RSPT4     | (8) 8d x 1½"   | 470         |
| RSPT6     | (8) 10d x 1½"  | 700         |
| RSPT6-2   | (14) 10d x 1½" | 955         |
| SPT22     | (8) 10d        | 725         |
| SPT24     | (12) 10d       | 1085        |

## HEADER CLIPS/HANGERS

## Simpson Strong-Tie

| Model No. | Width                            | Nailing  | Allow Vertical Load [lb] |
|-----------|----------------------------------|----------|--------------------------|
| FC4       | 3 <sup>9</sup> / <sub>16</sub> " | (8) 16d  | 800                      |
| FC6       | 5½"                              | (10) 16d | 920                      |
| HH4       | 3½"                              | (13) 16d | 1195                     |
| HH6       | 5½"                              | (18) 16d | 1595                     |

## USP Structural Connectors

| Model No. | Width                            | Nailing  | Allow Vertical Load [lb] |
|-----------|----------------------------------|----------|--------------------------|
| SFC4      | 3 <sup>9</sup> / <sub>16</sub> " | (8) 16d  | 550                      |
| SFC6      | 5½"                              | (10) 16d | 690                      |
| HH44      | 3 <sup>9</sup> / <sub>16</sub> " | (13) 16d | 1240                     |
| HH66      | 5½"                              | (18) 16d | 1650                     |

Connection values based upon a load duration factor of 1.6 and an equivalent specific gravity of 0.5.

## Base and Top Lateral Wind Reactions for Connectors [lb] 20 PSF Wind Load

See footnote 1 for conversions for other wind loads

| Height [ft] | Stud / Column Tributary Width [in] |     |      |     |     |     |      |      |      |      | Note  |
|-------------|------------------------------------|-----|------|-----|-----|-----|------|------|------|------|---|
|             | 12                                 | 16  | 19.2 | 24  | 36  | 48  | 60   | 72   | 84   | 96   |   |
| 8           | 80                                 | 107 | 128  | 160 | 240 | 320 | 400  | 480  | 560  | 640  | 1) For other wind loads, multiply reaction in table by the following factors:<br>10 PSF = 0.5<br>15 PSF = 0.75<br>25 PSF = 1.25<br>30 PSF = 1.5<br>40 PSF = 2.0 |
| 10          | 100                                | 133 | 160  | 200 | 300 | 400 | 500  | 600  | 700  | 800  |   |
| 12          | 120                                | 160 | 192  | 240 | 360 | 480 | 600  | 720  | 840  | 960  |   |
| 14          | 140                                | 187 | 224  | 280 | 420 | 560 | 700  | 840  | 980  | 1120 |   |
| 16          | 160                                | 213 | 256  | 320 | 480 | 640 | 800  | 960  | 1120 | 1280 |   |
| 18          | 180                                | 240 | 288  | 360 | 540 | 720 | 900  | 1080 | 1260 | 1440 |   |
| 20          | 200                                | 267 | 320  | 400 | 600 | 800 | 1000 | 1200 | 1400 | 1600 |   |
| 22          | 220                                | 293 | 352  | 440 | 660 | 880 | 1100 | 1320 | 1540 | 1760 |   |
| 24          | 240                                | 320 | 384  | 480 | 720 | 960 | 1200 | 1440 | 1680 | 1920 |   |

## VERSA-STUD® Allowable Holes and Notches

### Prescriptive Provisions

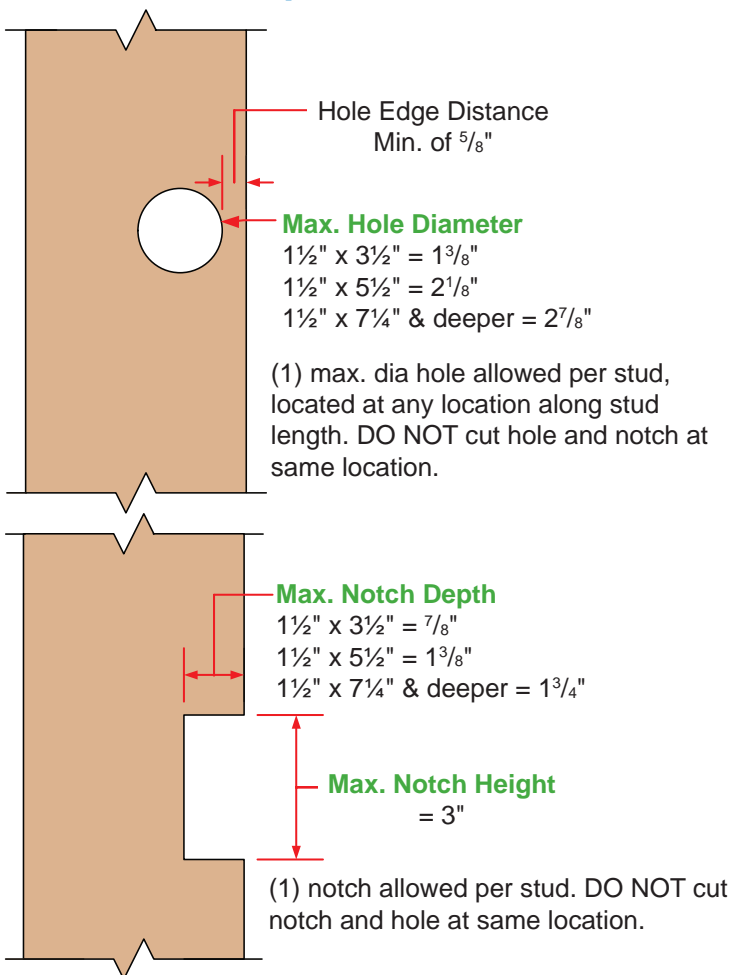

**Notes:**

- 1) Provisions valid only for studs within prescriptive design (see page 3).
- 2) Shield plates or nail stops to prevent nailing into wiring or piping shall be installed per the governing building code.

### Engineered Design Provisions

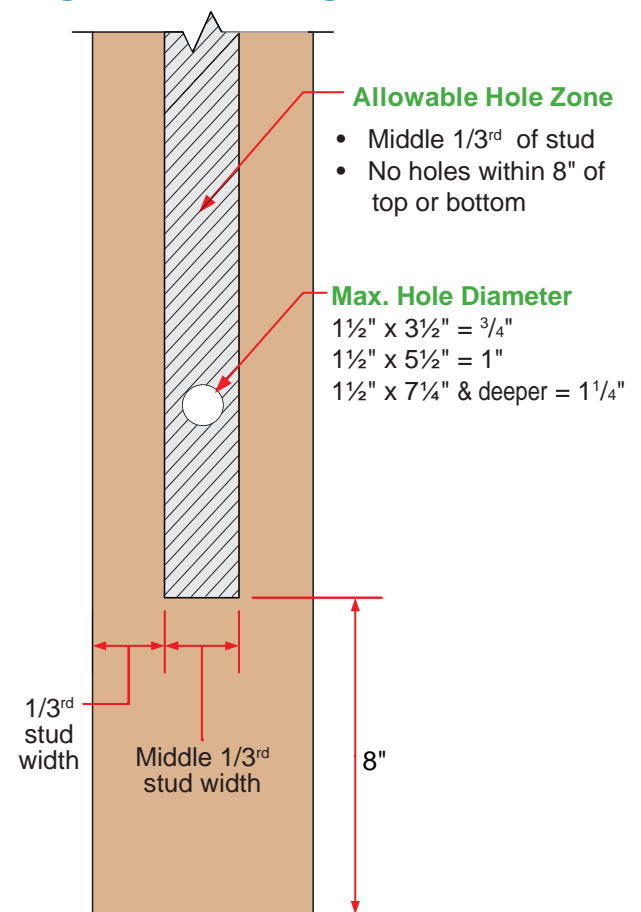

**Notes:**

- 1) DO NOT drill more than 3 holes in any 4-foot-long section of stud.
- 2) The vertical distance between adjacent holes must be at least 2 times the size of the larger hole
- 3) Holes no greater than  $\frac{3}{4}$ " dia may be cut in the hole zone shown in VERSA-LAM® columns.
- 4) For notches and larger holes, contact Boise EWP Engineering.

### 1½" VERSA-STUD® 1.7 2400 Design Properties

| Width [in] | Depth [in] | Weight [lb/ft] | Allowable Shear [lb] | Allowable Moment [lb-ft] | Moment of Inertia (I) [in <sup>4</sup> ] |
|------------|------------|----------------|----------------------|--------------------------|--|
| 1½         | 3½         | 1.3            | 998                  | 702                      | 5.4                                      |
| 1½         | 5½         | 2.1            | 1568                 | 1649                     | 20.8                                     |
| 1½         | 7¼         | 2.8            | 2066                 | 2779                     | 47.6                                     |
| 1½         | 9¼         | 3.6            | 2636                 | 4404                     | 98.9                                     |
| 1½         | 11¼        | 4.3            | 3206                 | 6374                     | 178.0                                    |

### VERSA-LAM® 1.7 2650 Column Design Properties

| Width [in] | Depth [in] | Weight [lb/ft] | Allowable Moment Edge <sup>(1)</sup> [lb-ft] | Allowable Moment Flat <sup>(1)</sup> [lb-ft] | Moment of Inertia (I) [in <sup>4</sup> ] |
|------------|------------|----------------|--|--|--|
| 3½         | 3½         | 3.6            | 1810   | 1639   | 12.5                                     |
| 3½         | 5¼         | 5.4            | 3892   | 3525   | 42.2                                     |
| 3½         | 7          | 7.1            | 6702   | 6069   | 100.0                                    |
| 5¼         | 5¼         | 8.0            | 5838   | 5287   | 63.3                                     |
| 5¼         | 7          | 10.7           | 10053  | 9104   | 150.1                                    |
| 7          | 7          | 14.3           | 13403  | 12139  | 200.1                                    |

1) Allowable bending stress is 2650 psi on edge (parallel to gluelines), 2400 psi flat (perpendicular to gluelines)

### Allowable Stress Value Comparison

| Product                            | Bending $F_b$ [psi] | Compression Parallel to Grain $F_c$ [psi] | Modulus of Elasticity E [psi] | Horizontal Shear $F_v$ [psi] |
|------------------------------------|---------------------|---|-------------------------------|------------------------------|
| <b>VERSA-STUD® 1.7 2400</b>        | 2400                | 3000                                      | 1700000                       | 285                          |
| Douglas fir #2 Grade               | 900                 | 1350                                      | 1600000                       | 180                          |
| Spruce Pine Fir (North) #1/2 Grade | 875                 | 1150                                      | 1400000                       | 135                          |
| Hem-Fir # 2 Grade                  | 850                 | 1300                                      | 1300000                       | 150                          |
| Western Woods #2 Grade             | 675                 | 900                                       | 1000000                       | 135                          |

- Design values are for loads applied to the narrow face of the studs.
- Dimension lumber values taken from 2005 Edition, NDS Design Values for Wood Construction. (per 2006 IBC/IRC)
- Repetitive member and size factors have not been applied.



## Prescriptive Nailing

Since VERSA-STUD® may be used in prescriptive design in the IBC and IRC, it may be installed as studs in braced wall panels. Standard nailing for prescriptive wood stud walls with structural sheathing is 6d common nails for panels  $\frac{5}{16}$ " to  $\frac{1}{2}$ " thick, 8d common nails for panels  $\frac{19}{32}$ " to 1" thick, spaced at 6" on-center on panel edges and 12" on-center in intermediate studs.

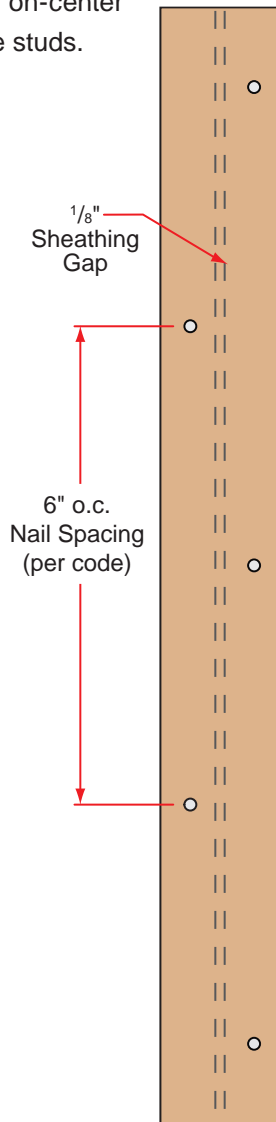

**Single Stud Nailing at Panel Edges**

## Shear Walls

VERSA-STUD® may be used in shear wall construction. Allowable shear values may be determined by using Table 2306.4.1 of the IBC, shear walls with Douglas fir-Larch framing, subject to the following conditions:

1. A double VERSA-STUD® must be used at all panel edges of shear walls. Studs must be stitch-nailed together with two rows of 10d common nails at 8" on-center, staggered.
2. Nails at panel edges must be staggered along two nailing lines spaced approximately  $\frac{1}{2}$ " apart. Nails at panel edges must also be at least  $\frac{3}{8}$ " from the edges of the VERSA-STUD® and the wood structural panel (see detail below).
3. The tabulated shear values for nailed wood structural panel shear walls using 8d or 10d box or common nails at a panel edge nailing of 2" must be multiplied by a factor of 0.9.
4. The tabulated shear values for nailed wood structural panel shear walls using 10d box or common nails at a panel edge nailing of 3" must be multiplied by a factor of 0.9.

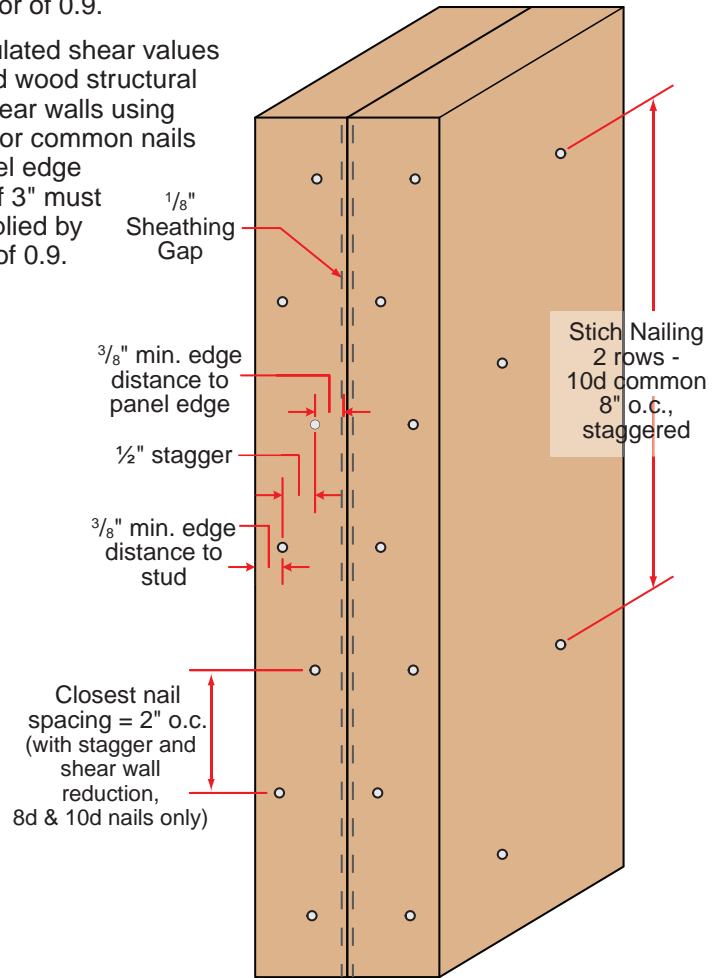

**Double Stud Nailing Edges Shear Wall Only**

## Fire Assemblies

VERSA-STUD® is permitted as a direct replacement for solid-sawn lumber in any fire-resistance-rated wall assembly listed in Table 720.1(2) of the IBC, provided the VERSA-STUD® have a minimum depth of  $\frac{5}{2}$ ".

Boise Cascade EWP is proud to introduce BC COLUMN®. BC COLUMN® is new software that will allow customers the ability to design columns using Boise Cascade Engineered Wood Products.



### Using BC COLUMN®, users can quickly:

- Design a column or stud using Boise Cascade Engineered Wood Products.
- Add gravity and out-of-plane lateral loads.
- Add bracing/supports.
- Select and test products in the design.
- Refine performance factors.
- Print design reports.

### The steps are simple. To use:

- Set up the project:
- Launch BC COLMNN®.
- Enter project information.
- Specify the design and select a product.
- Describe the type of column or stud, its height and its bracing.
- Adjust the axial load and add additional out-of-plane lateral loads.
- Select a product. Specify the Deflection.
- Specify the column/stud deflection.
- Analyze and refine designs.
- Review and print design reports.

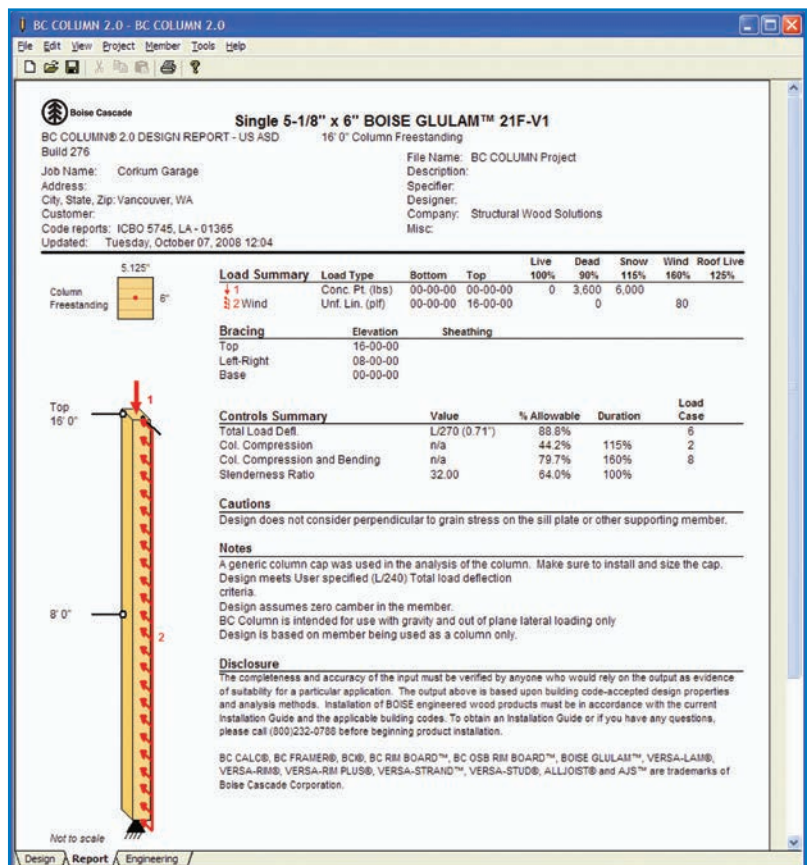
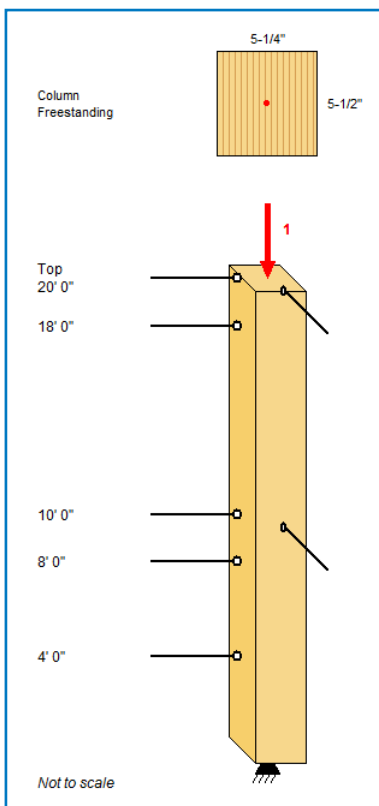
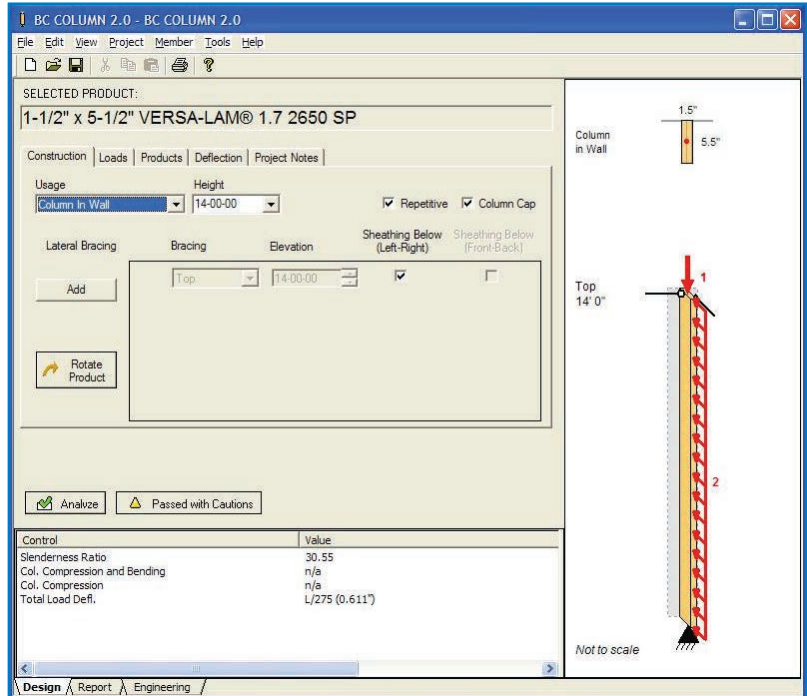

BC COLUMN® is installed with BC CALC for the US market ONLY.

To download of BC CALC/BC COLUMN® US

<http://www.bc.com/wood/ewp/software/bccalc.html>



New BC FRAMER® represents a huge technological leap to help you improve the efficiency and profitability of your engineered wood products business. Boise Cascade will provide you what we believe is now the industry's best design software, offering far greater productivity than even our current version of BC FRAMER®. This new software package will help your design department work faster and accomplish more. You don't get paid to do drawings, but at least now you can do them in less time, and better.

- Shrink design time with BC FRAMER® model sharing.
- Save time & prevent mistakes with best-in-industry file integration.
- Experience the efficiencies of BC FRAMER® whole house modeling.
- Draw floor and wall plans simultaneously with BC FRAMER®.
- Check the plan every possible way with BC FRAMER® full 3-D viewer.
- Create a master plan and multiple options that can be quickly selected and exported to a plot-specific file in a few minutes – a fraction of the time it could have taken in the past.

Information can also be obtained at 1-800-405-5969 or email us at [EWPSupport@BC.com](mailto:EWPSupport@BC.com).

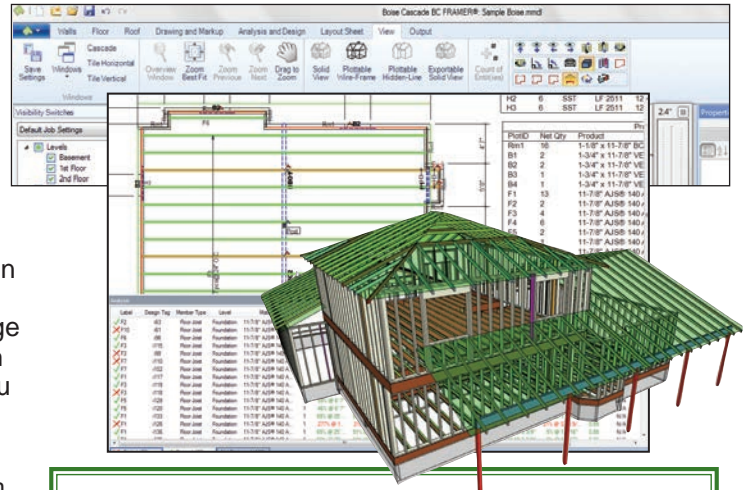

### RECOMMENDED HARDWARE

- **CPU:** Quad Core 64 bit Processor
- **L2 Cache:** 3MB/Core
- **RAM:** 4.0GB to 8.0 GB
- **Video:** Full support for DirectX 9; Single monitors, 1280x1024 128MB; Dual monitor, 1280x1024 256MB (Minimum 1024x768)
- **Operating Systems:** Windows® 7 or 8 (Professional Editions 32-bit and 64-bit)

Actual specifications vary by user and will be assessed prior to installation.

## BC CALC® 4.0 Sizing Software

BC CALC® is simple to use, yet robust enough to analyze most all joist, beam, and column applications. Once an analysis is run, the user may print an easy-to-read design report that displays the span and load information with the analysis results.

BC COLUMN® has now been merged into BC CALC®, allowing the sizing of joists, beams, rafters, columns, and studs all in one convenient program.

In addition to BCI® & AJS® Joists, VERSA-LAM®, and BOISE GLULAM®, BC CALC® also offers the analysis of solid sawn lumber and timber members. Thus BC CALC® is the only program needed to analyze structural wood members.



Boise Cascade has provided BC CALC® free of charge to the design community since 1994.

### COMPUTER REQUIREMENTS

PC with any current version of MS Windows®, along with an internet connection. For questions regarding BC CALC®, call 1-800-405-5969 or email [EWPSupport@BC.com](mailto:EWPSupport@BC.com).

To Download BC CALC US,  
<http://www.bc.com/wood/ewp/software/bccalc.html>

**SELECTED PRODUCT:**  
 5-1/8" x 6" BOISE GLULAM® Combination #3 DF

| Construction               | Loads | Products | Depth  | Project Notes |
|----------------------------|-------|----------|--------|---------------|
| VL 1-3/4" SP 2.0 3100      |       | 5-1/8"   |        |               |
| VL 2-5/8" SP 2.0 3100      |       | 5-1/4"   |        |               |
| VL 3-1/2" SP 2.0 3100      |       | 5-1/2"   |        |               |
| VL 5-1/4" SP 2.0 3100      |       | 5-1/2"   |        |               |
| 3-1/8" VERSA-LAM® Glulam   |       | 7"       | 7-1/2" |               |
| 3-1/2" 30F-E4 DF/SP KING I |       | 5"       |        |               |
| 3-1/2" Combination #3 DF   |       |          |        |               |
| 5-1/8" 24F-V8/DF Glulam    |       |          |        |               |

| Reaction Summary (Down / Uplift) (lbs) | Live    | Dead    | Snow | Wind | Roof Live |
|--|---------|---------|------|------|-----------|
| B0, 4'                                 | 4,125.0 | 7,044.0 |      |      |           |
| B1, 3-1/2"                             | 4,115.0 | 7,026.0 |      |      |           |

| Load Summary    | Load Type          | Ref. Stat | End      | 100%     | 90% | 115% | 160% | 125% | OC5      |
|-----------------|--------------------|-----------|----------|----------|-----|------|------|------|----------|
| I Standard Load | Unf. Area (Roof*2) | L         | 00-00-00 | 33-06-00 | 15  | 30   |      |      | 14-00-00 |

| Controls Summary | Value          | % Allowable | Case | Location | Disclosure |
|------------------|----------------|-------------|------|----------|------------|
| Pcs. Moment      | 80,856 ft-lbs  | 69.2%       | 115% | 4        | 16-09-04   |
| End Shear        | 6,837 lbs      | 32.2%       | 115% | 4        | 02-03-00   |
| Total Load Defl. | L/208 (1,904") | 85.5%       | n/a  | 4        | 16-09-04   |
| Live Load Defl.  | L/330 (1,201") | 72.8%       | n/a  | 5        | 16-09-04   |
| Span / Depth     | 19.9           | n/a         | n/a  | 0        | 00-00-00   |

| Bearing Supports | Dim. (L x W) | Value      | % Allow Support | % Allow Member | Material    |
|------------------|--------------|------------|-----------------|----------------|-------------|
| B0 Wall/Plate    | 4' x 7'      | 11,169 lbs | 98.5%           | 93.2%          | Heavy-Fir   |
| B1 Wall/Plate    | 3-1/2' x 7'  | 11,142 lbs | n/a             | 60.6%          | Unspecified |

**Caution:**  
 For roof members with slope (1/4W1) or less final design must ensure that ponding instability will not occur.  
 For roof members with slope (1/2W1) or less final design must account for Rain-on-Snow surcharge load.

**Notes:**  
 Design meets code minimum (L/240) Total load deflection criteria.  
 Design meets Code minimum (L/240) Live load deflection criteria.  
 Calculations assume member is fully laterally braced.



If in doubt ask! For the closest Boise Cascade EWP distributor/support center, call **1-800-232-0788**



Boise Cascade Engineered Wood Products build better homes with stronger, stiffer floors using only wood purchased in compliance with a number of green building programs. Take a moment to view our sustainability certification site at <http://www.bc.com/sustainability/certification.html> or view our green brochure at [http://www.bc.com/wood/ewp/Boise\\_EWP\\_Green.html](http://www.bc.com/wood/ewp/Boise_EWP_Green.html).

Boise Cascade Engineered Wood Products throughout North America can now be ordered FSC® Chain-of-Custody (COC) certified, enabling homebuilders to achieve LEED® points under

U.S. Green Building Council® residential and commercial green building programs including LEED for Homes and LEED for New Construction. Boise Cascade Engineered Wood Products are available as PEFC® Chain-of-Custody certified, SFI® Chain-of-Custody certified and SFI Fiber-Sourcing certified, as well as NAHB Research Center Green Approved, enabling homebuilders to also obtain green building points through the National Green Building Standard.

**Great products are only the beginning.®**

### Lifetime Guaranteed Quality and Performance

Boise Cascade warrants its BCI® Joist, VERSA-LAM®, and ALLJOIST® products to comply with our specifications, to be free from defects in material and workmanship, and to meet or exceed our performance specifications for the normal and expected life of the structure when correctly stored, installed and used according to our Installation Guide.

For information about Boise Cascade's engineered wood products, including sales terms and conditions, warranties and disclaimers, visit our website at [www.BCewp.com](http://www.BCewp.com)

BOISE CASCADE, TREE-IN-A-CIRCLE, BCI, BC CALC, BC FRAMER, BC RIM BOARD, BOISE CASCADE, BOISE GLULAM, SIMPLE FRAMING SYSTEM, VERSA-LAM, VERSA-RIM, VERSA-STRAND, and VERSA-STUD are trademarks of Boise Cascade, L.L.C. or its affiliates.

Your Dealer is:

If no dealer is listed, call 1-800-232-0788



**Boise Cascade**  
Engineered Wood Products