

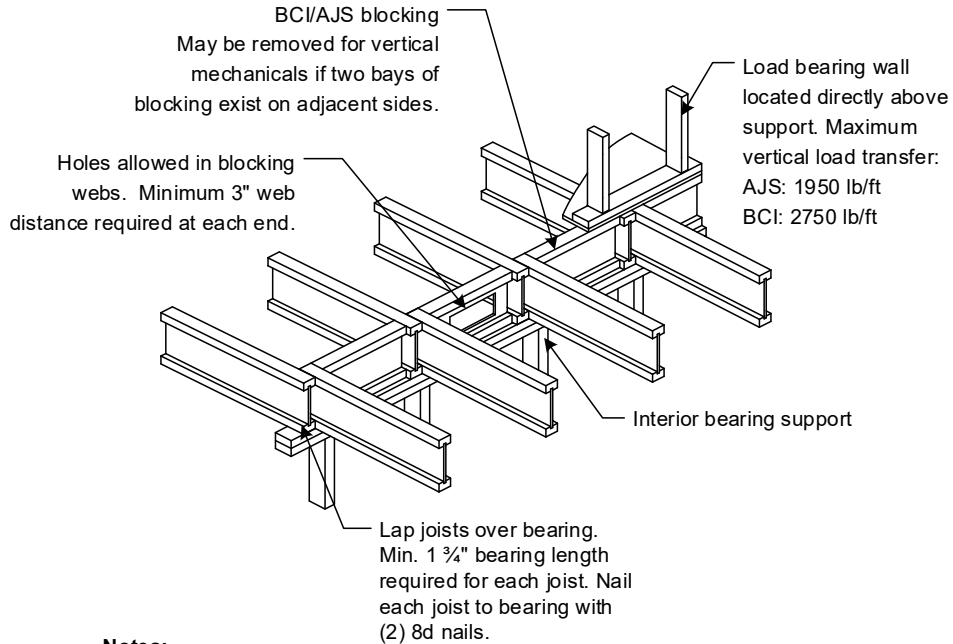

**Specific Application Detail**

**Lapped Joist Bearing at Interior Supports**

**Load Bearing Wall Above – Joist Blocking**



**Notes:**

1) This detail is applicable only for construction falling under the NBCC 2020 Part 9.

**Load Bearing Wall Above – 2x Squash Blocks & Flat Blocking**

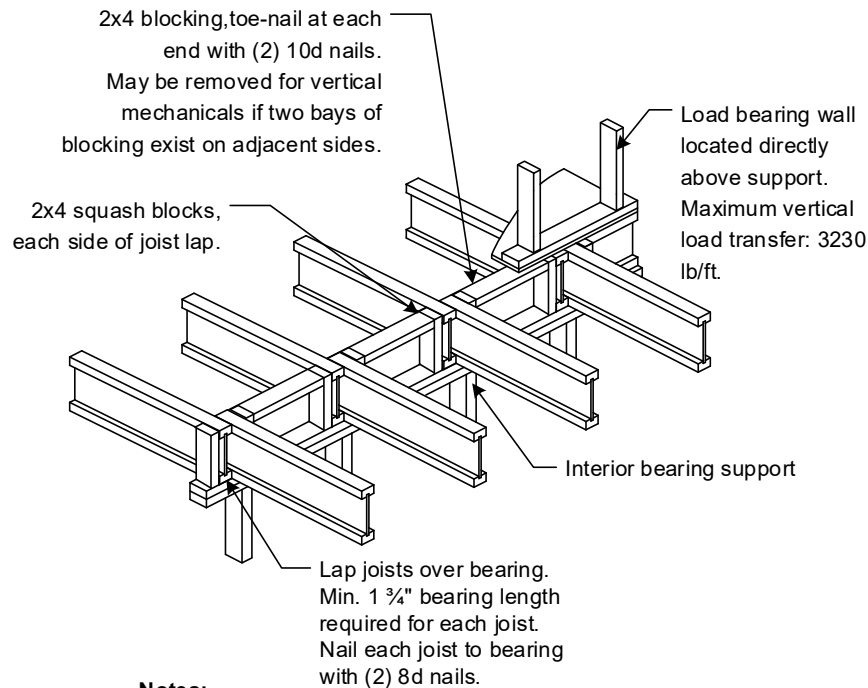

**Notes:**

1) This detail is applicable only for construction falling under the NBCC 2020 Part 9.

2) Detail shown above provides adequate lateral stability for BCI/AJS joists. Additional lateral resistance may be required in high wind and/or seismic load areas; consult with project's design professional of record.



**Specific Application Detail**

**Non-Load Bearing Partition Wall Above**

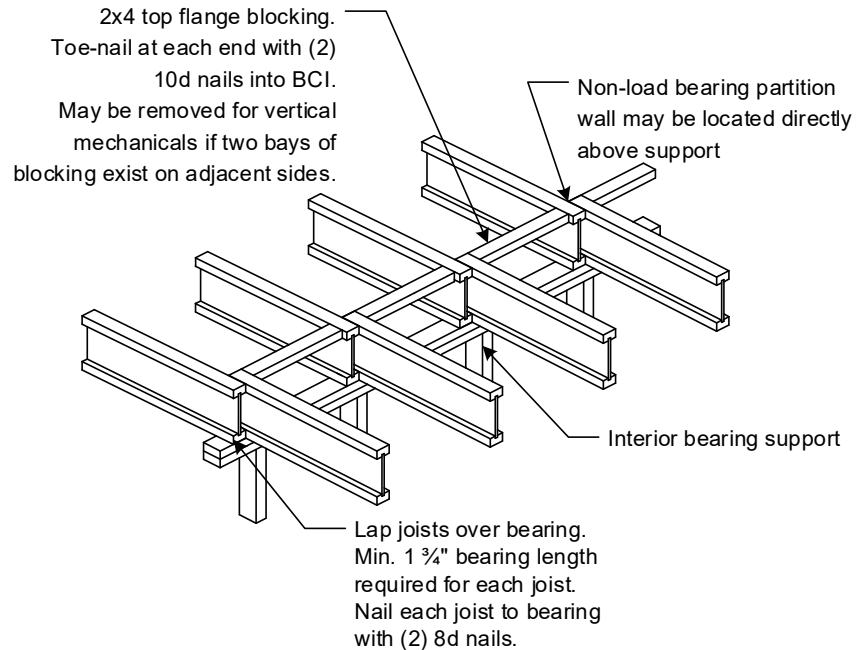

**Notes:**

- 1) This detail is applicable only for construction falling under the NBCC 2020 Part 9.
- 2) Detail shown above provides adequate lateral stability for BCI/AJS joists. Additional lateral resistance may be required in high wind and/or seismic load areas; consult with project's design professional of record.