



## Connecting Multiple-Ply 1 3/4" Versa-Lam<sup>®</sup> Beams with FastenMaster TrussLok<sup>®</sup> Screws

When using multiple ply 1 3/4" Versa-Lam beams to create a wider member, the connection of the plies is as critical as determining the beam size. When side loaded beams are not connected properly, the inside plies do not support their share of the load and thus the load carrying capacity of the full member decreases significantly.

FastenMaster TrussLok screws are an acceptable fastener to connect multiple ply 1 3/4" Versa-Lam beams. The following is an allowable load chart for determining the proper connection schedule:

# of Members	Screw Size	2 rows – 24" o.c.	3 rows <sup>(1)</sup> – 24" o.c.	2 rows – 16" o.c.	3 rows <sup>(1)</sup> – 16" o.c.	2 rows – 12" o.c.	3 rows <sup>(1)</sup> – 12" o.c.
2	3 3/8" TrussLok	534	801	801	1202	1068	1602
3	5" TrussLok	433	649	649	974	866	1299
4 <sup>(2)</sup>	6 3/4" TrussLok	387	580	580	870	773	1160

**Notes:**

- 1) 3 row connections allowed for 11 7/8" and deeper beams, middle row at centerline.
- 2) 4 Ply Versa-Lam beams shall be side loaded (framing) from both sides. If not equally loaded, PLF load from lesser side shall be at least 25% of opposite side.
- - All TrussLok screws may be installed from one side of multiple ply Versa-Lam beams.
- - For top-loaded only beams, a minimum fastener schedule of 2 rows @ 24" o.c. is required for 18" and shallower depth beams, 3 rows @ 24" o.c. for 24" depth beams
- - Fastener values based upon FastenMaster ICC ESR report 1078 and Technical Bulletin 1.
- - Spacing Requirements

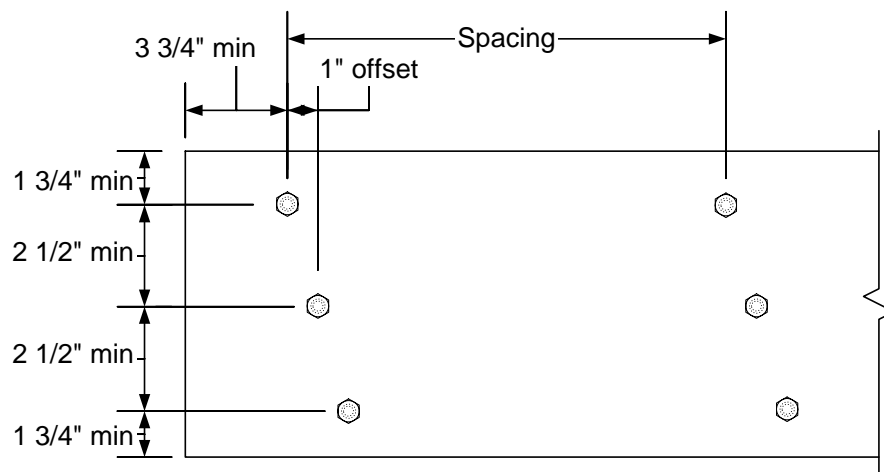

For further information, please consult FastenMaster TrussLok Technical Bulletin 1.



**Connection Design Example**

Given: Beam shown below is supporting residential floor load (40 psf live load, 10 psf dead load) and is spanning 16'-0". Beam depth is limited to 14".

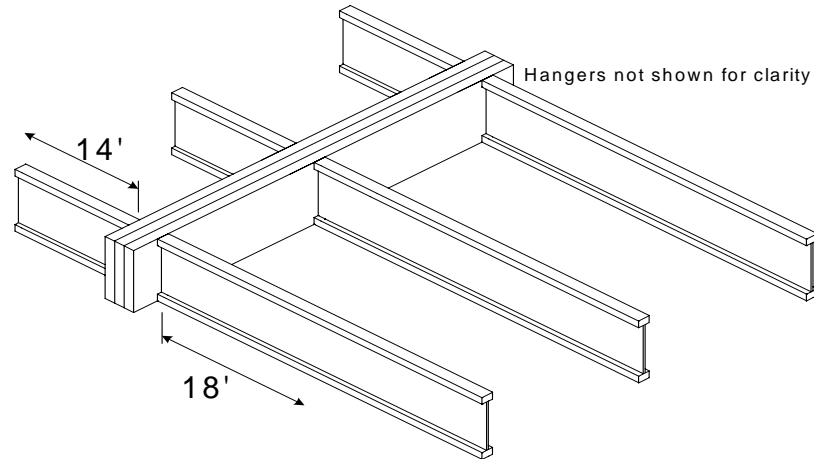

Find: A multiple 1 3/4" ply Versa-Lam that is adequate to support the design loads and the member's proper connection schedule with FastenMaster TrussLok screws.

- 1) Calculate the tributary width that beam is supporting:  $14'/2 + 18'/2 = 16'$ .
- 2) Use PLF tables in *Boise Cascade EWP Specifier Guide* or enter the loads and span in BC Calc and run Best Beam for 2, 3 & 4 ply beams: A Triple 1 3/4" x 14" Versa-Lam 3100 is found to adequately support the design loads.
- 3) Calculate the maximum plf load from one side (the right side in this case).  
Max. Side Load =  $(18'/2) \times (40 + 10 \text{ psf}) = 450 \text{ plf}$
- 4) Go to the table on previous page, the proper connection schedule must have a capacity greater than the max. side load:

***TrussLok Screws: 5" Long - 3 rows @ 24" o.c.: 649 plf > 450 plf OK!***