



Vertical Load Transfer over Bearings within BC FRAMER® & BC CALC®

Short bearings are defined as being 14" or less in length in BC FRAMER® and BC CALC®. Short bearings include traditional platform framing as shown in Figure 1 below.

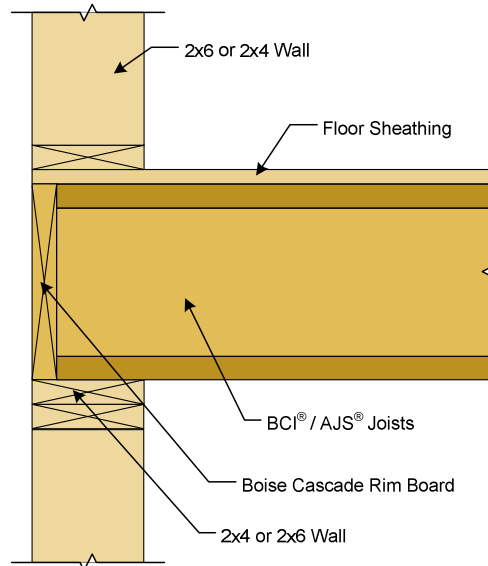

Figure 1: Traditional Platform Framing

Due to energy conservation trends in construction, wood framed walls are occasionally framed thicker than the standard 2x4 or 2x6 thickness. In these conditions, blocking installed flush to the inside of the walls is required in addition to rim board on the exterior (see Figure 2).

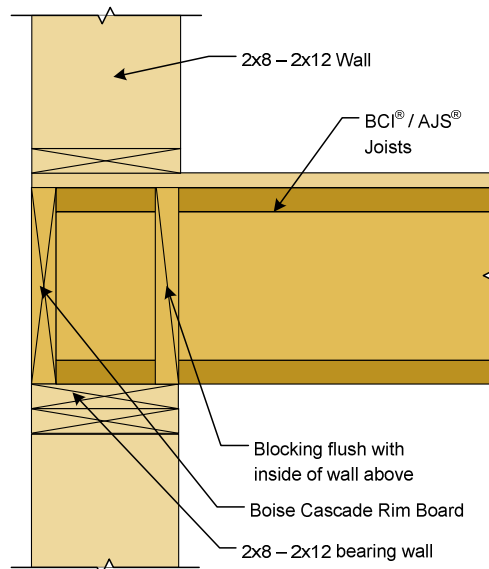

Figure 2: Thicker Wall Platform Framing



Since the rim board and blocking shown in Figures 1 and 2 are intended to transfer all vertical load from above, such loads are not applied to joists or beams in these bearing areas.

Longer bearings are typically provided by bearing walls that run parallel to the joist or beam length that the wall supports (see Figure 3).

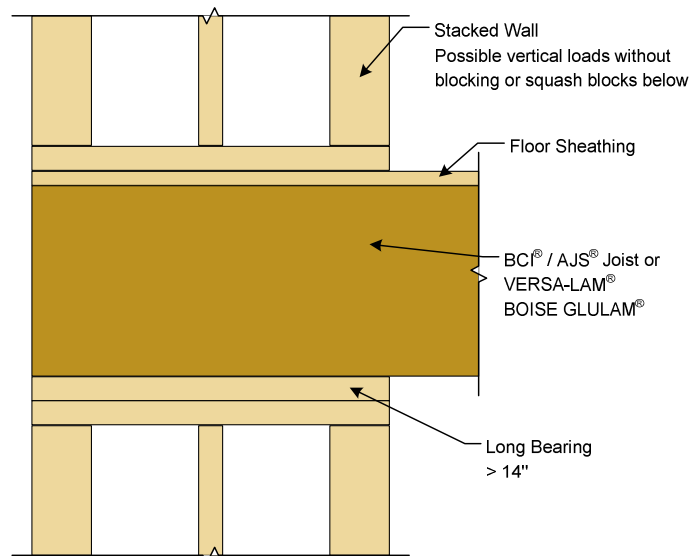

Figure 3: Long Bearing Application

Due to the larger bearing area and the resulting higher probability that vertical load transfer elements (rim board, blocking, squash blocks) have not been installed, all vertical loads above long bearings are assumed to transfer through the joist or beam at the bearing. BC FRAMER® and BC CALC® analyze the joist / beam as follows:

Distributed Load: The member is analyzed for crushing under any uniform loads present over the long bearing contact area. BCI® / AJS® joists have a fixed capacity for uniform vertical load transfer, while rectangular section products (VERSA-LAM®, BOISE GLULAM® and solid sawn products) are analyzed by a compression perpendicular to grain stress check. Actual stress (load multiplied by contact area) is compared to the published allowable compression bearing stress.

Concentrated Load: The member is analyzed for crushing of the top edge under any concentrated loads present over the long bearing. A 3.5" wide contact surface along its top edge is assumed, based on a worst-case 2x4 wall plate or 4x4 post. BCI® / AJS® joists have a fixed capacity for any concentrated loading condition, while rectangular products are analyzed by a compression perpendicular to grain stress check. Concentrated loads bearing on rectangular beam products through larger posts or plates can be analyzed by calculation. Allowable compression perpendicular to grain stresses are shown on page 3:



Product	Compression Perpendicular to Grain [lb/in ²]
VERSA-LAM [®] 1.4 1800	525
VERSA-LAM [®] 1.7 2400 & higher grades	750
BOISE GLULAM [®] 24F-V4/DF & 24F-V8/DF	650
BOISE GLULAM [®] 20F-V12/AC & 20F-V13/AC	560

An example calculation follows:

Given:

6x6 vertical post bearing on 7" wide VERSA-LAM[®] 2.0 over a long bearing, transferring an axial load of 10,000 pounds

Solution:

Actual compression stress: $10,000 \text{ lb} / (5.5" \times 5.5") = 330 \text{ lb/in}^2$

Allowable stress: $750 \text{ lb/in}^2 > 330 \text{ lb/in}^2$ OK

VERSA-LAM[®] beam has adequate compression stress for given vertical axial load