

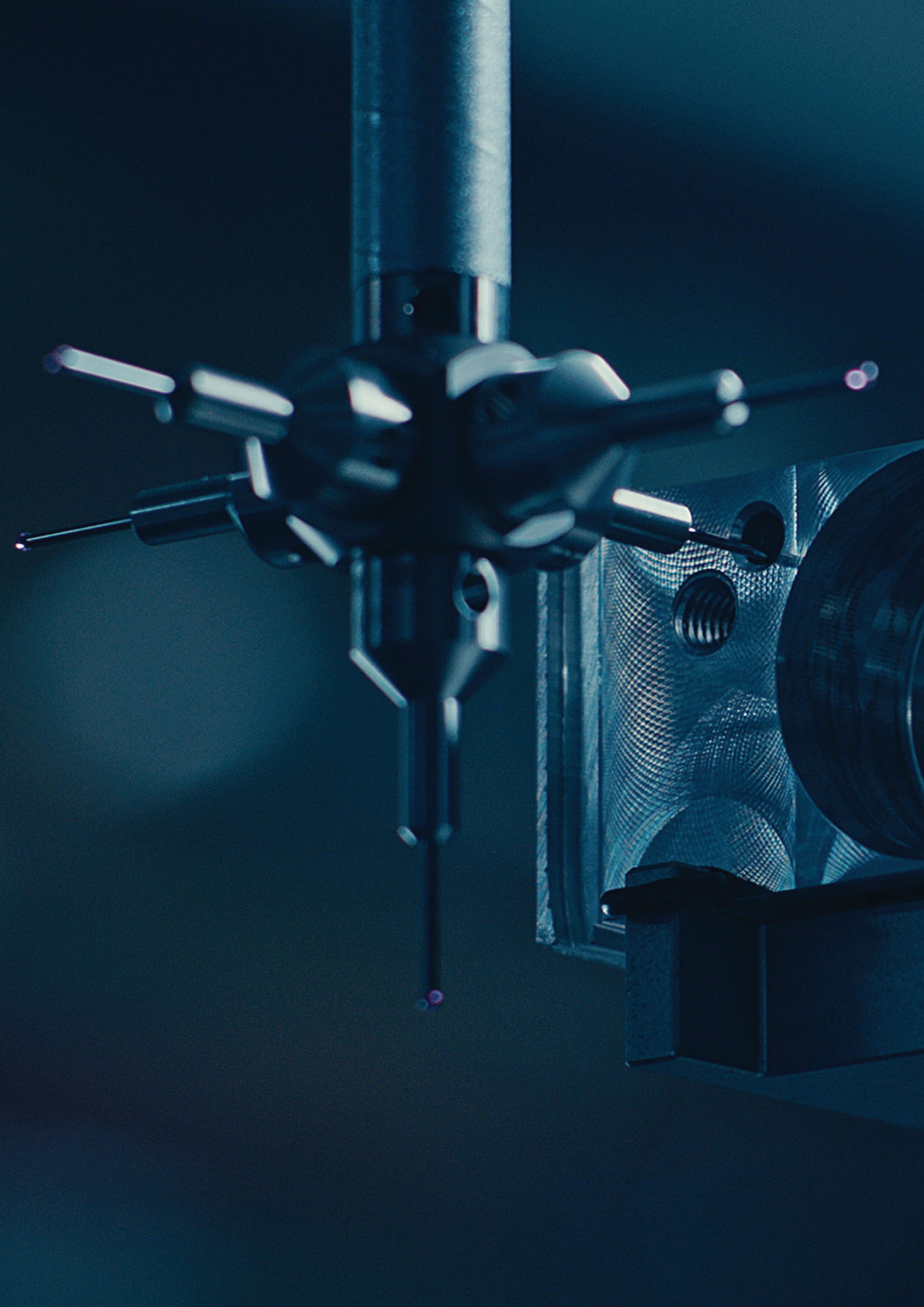

FritsJurgens®

SYSTEM ONE
TECHNICAL DATA SHEET



FROM THE NETHERLANDS, FRITSJURGENS CREATES PIVOT HARDWARE SOLUTIONS OF THE HIGHEST POSSIBLE QUALITY THAT EXCEED INDUSTRY STANDARDS AND OUR CLIENT'S EXPECTATIONS. THESE SOLUTIONS ENABLE ENDLESS PIVOT DOOR DESIGN POSSIBILITIES.

- Hidden hardware** Only small floor and ceiling plates are visible. All the hardware is hidden in the door.
- Unlimited design** The door can be of any height and made with every type of material, creating unlimited design possibilities.
- Motion technology** Motion technology puts hydraulic power to use, creating a smooth and controlled door movement.
- Timeless quality** Built from high-performance materials, the systems are maintenance-free and perform flawlessly.

CONTINUOUS IMPROVEMENT

FritsJurgens strives for the best quality possible. Every system that leaves the FritsJurgens headquarters is designed, fabricated, and tested with the greatest attention to detail and with only the best quality materials. This enabled us to create maintenance-free hinges: even after 136 years of daily use, the hinge will still function flawlessly.

WORLDWIDE NETWORK

Architects, designers, and door manufacturers worldwide work with FritsJurgens. Our pivot hinges are available through a trusted partner-network in 80+ countries.

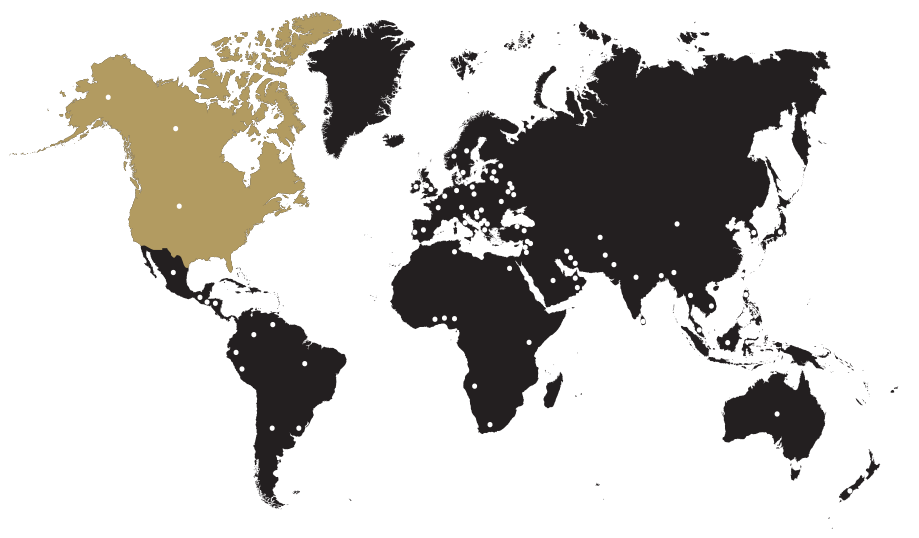

● Distributed in North America by Bridgeport Worldwide

OVERVIEW

The most ideal pivot hinge for narrow profile doors. With a height of just 18 mm, this pivot hinge can be applied in a broad range of pivot door designs and applications.

COMPONENTS

- 1.1 Bottom pivot System One 40 mm
- 1.2 Bottom pivot System One 70 mm
- 2.1 Floor plate - Round
- 2.2 Floor plate - Rectangular
- 2.3 Floor plate - Rectangular NA
- 2.4 Floor plate - Flush squared
- 2.5 Floor plate - Flush rounded

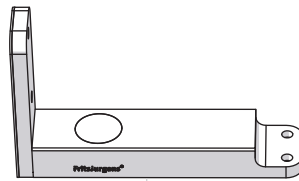

1.1

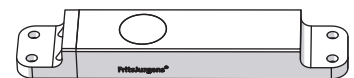

1.2



2.1



2.2



2.3

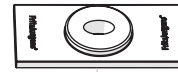

2.4

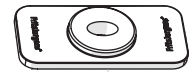

2.5

FUNCTION

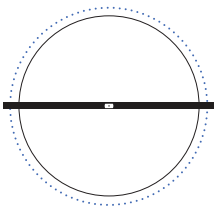

- Double-acting doors
- Rotation 360°

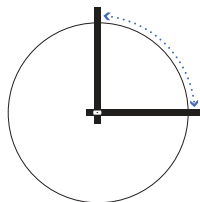

- Single-acting doors
- Rotation 90°
- External stop required

MOVEMENT

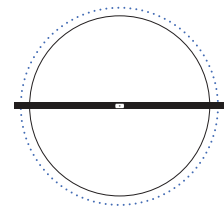

360° free-swinging pivot

VARIANTS

WEIGHT OF THE DOOR

Class G | 0 - 500 kg (0 - 1100 lbs)

70 MM

Side or middle placement, pivot position at least 70 mm from the edge of the door.

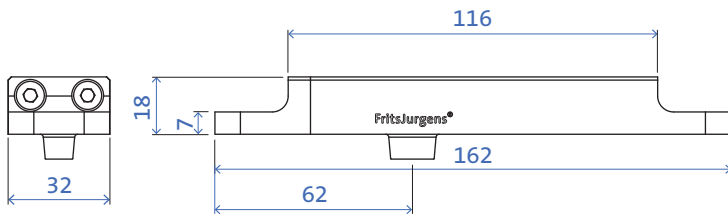

40 MM

Side placement, pivot position at 40 mm from the edge of the door.

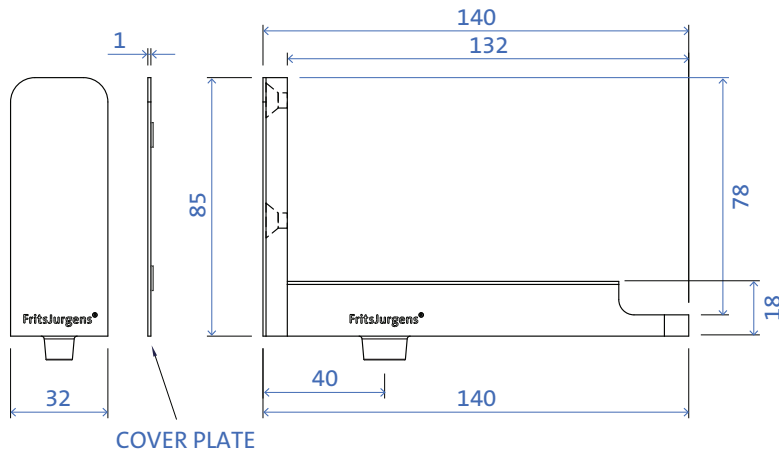

TECHNICAL SPECIFICATION

FEATURES

Rotation 360° and 90° with external stop

Hold position No

Free-swinging Yes

Self-closing No

For double-acting doors Yes

For single-acting doors Yes

For door frame/jambs Yes

Door weight 0 - 500 kg (0 - 1100 lbs)

SPECIFICATION

Weight class 1 class, G

Pivot point possibilities 40 mm, ≥70 mm, offset, max. middle of the width

Floor plate compatibility Floor plate rectangular NA & all floor plates of System M family

Top pivot compatibility TP-40, TP-70, TP-R, TP-CG

GAPS OVERVIEW

Gap below the door 7 mm (Floor plate Flush) or 11 mm (Floor plate squared, round)

Required gap above the door 4 mm - 10 mm

Material of the product Stainless steel, anodized aluminum

Minimum gaps left/right Depends on door thickness, see Gap Calculator

HINGE PLATES

Floor plates



Floor plate rectangular NA
Stainless Steel



Floor plate rectangular
Black



Floor plate round
Stainless Steel



Floor plate round
Black



Floor plate Flush rounded

Sunk into door frame or floor, so flush with surrounding area. Ideal for drop seals.



Floor plate Flush squared

Sunk into door frame or floor, so flush with surrounding area. Ideal for drop seals.

 Shown are the number of mounting pins included in the package, pre-mounted plus any additional ones. Floor plate rectangular comes with extra pins for different floor types.

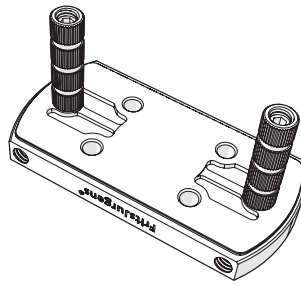
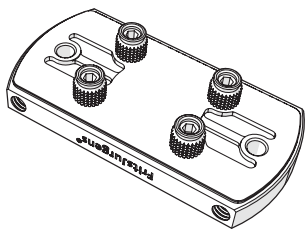

Cover plates for System One 40 mm



SS
Stainless steel cover plate



BK
Black cover plate

CONFIGURATIONS

System One, pivot position ≥ 70 mm (Class G), non-adjustable floor plate

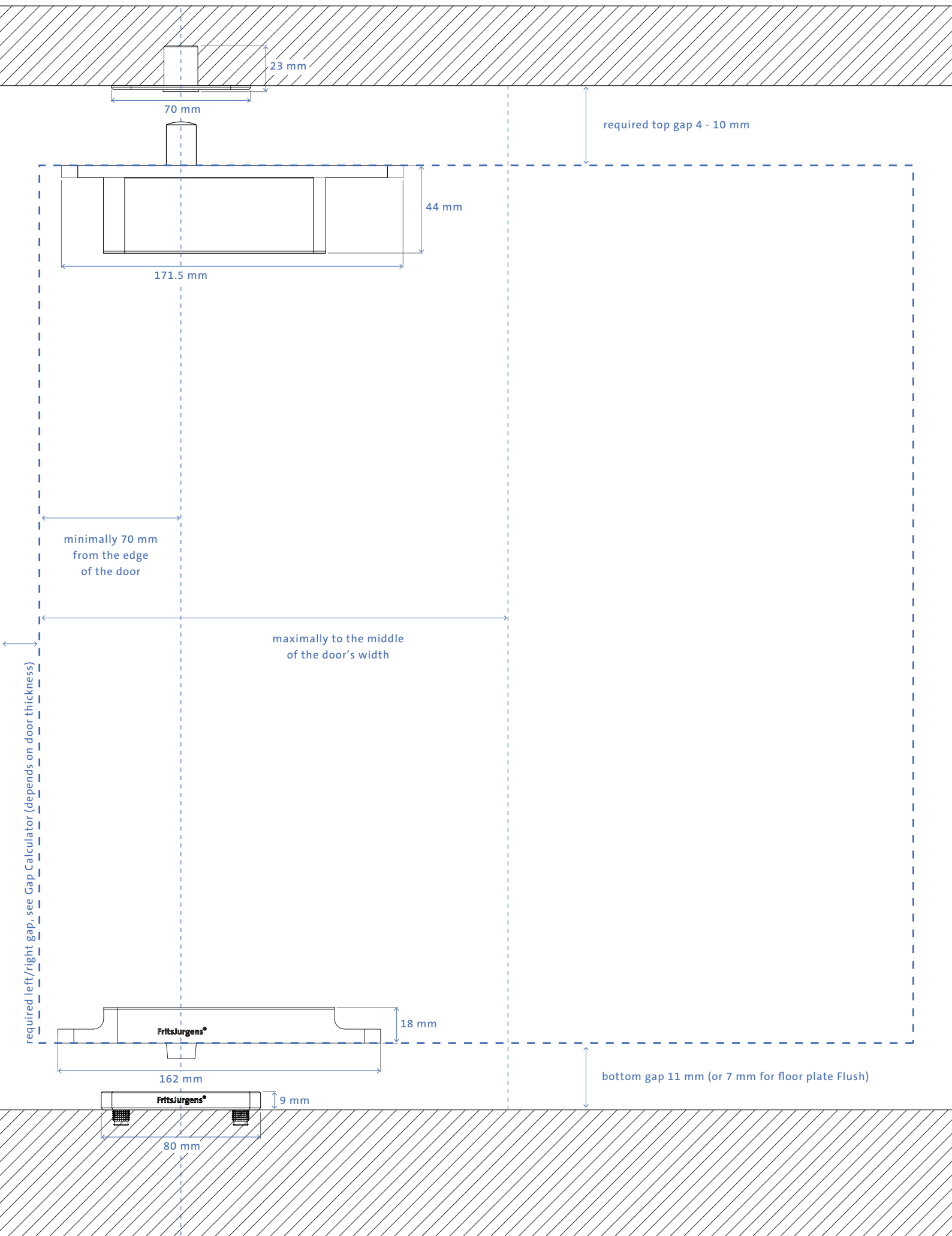

System One, pivot position 40 mm (Class G), floor plate rectangular

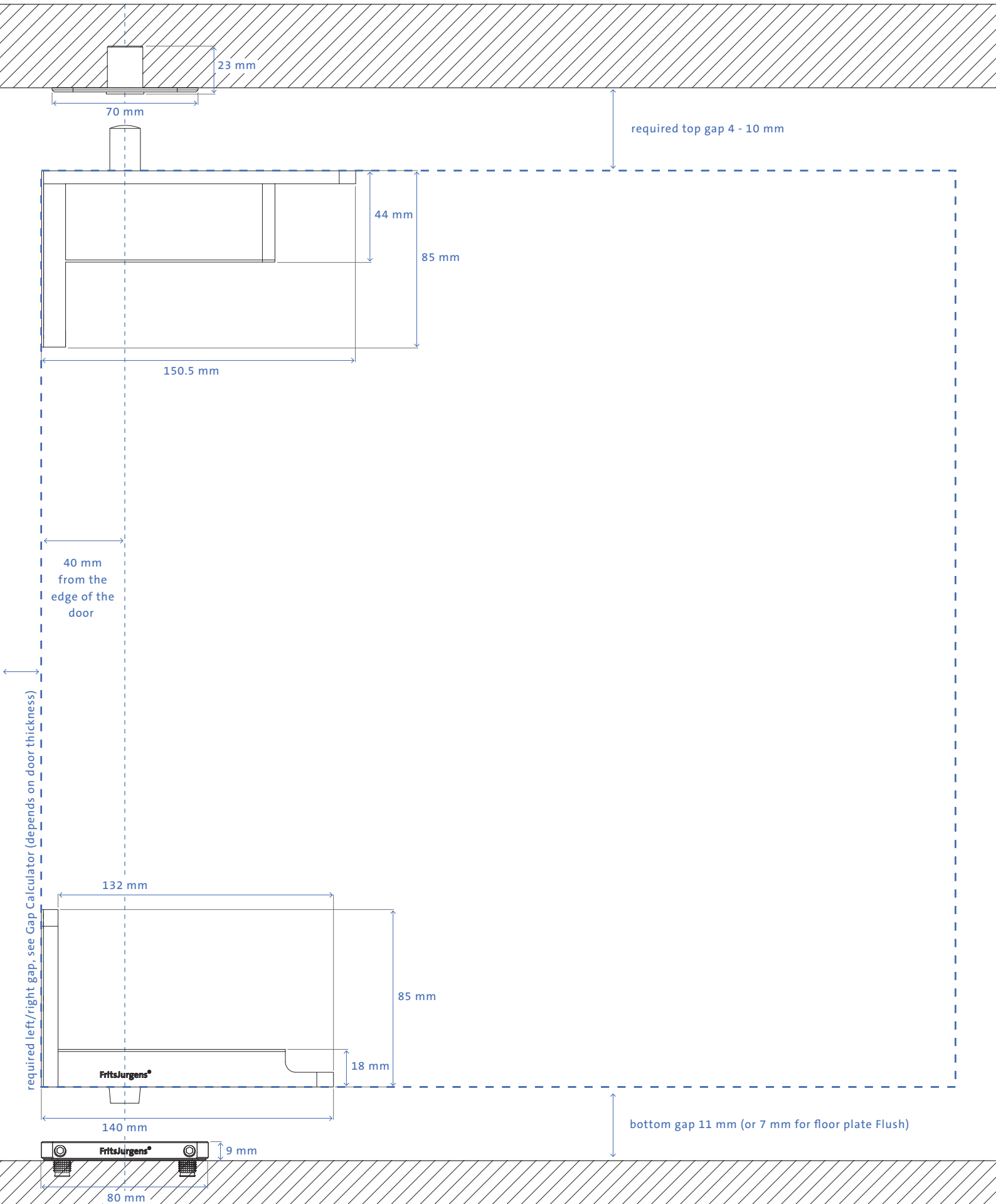

System One, pivot position ≥ 91 mm with Cable Grommet (Class G), non-adjustable floor plate

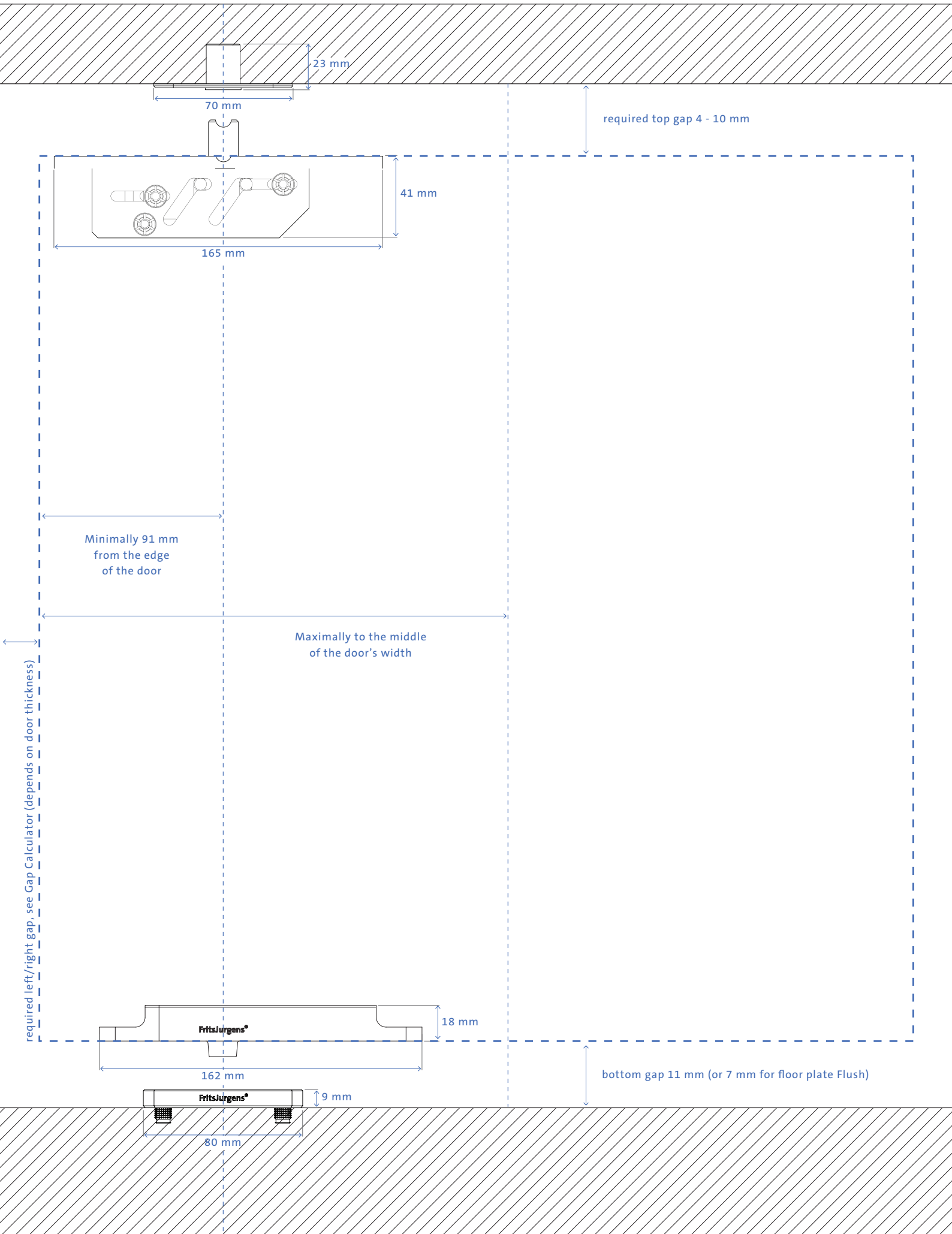

System One with TP-R (Class G), floor plate rectangular

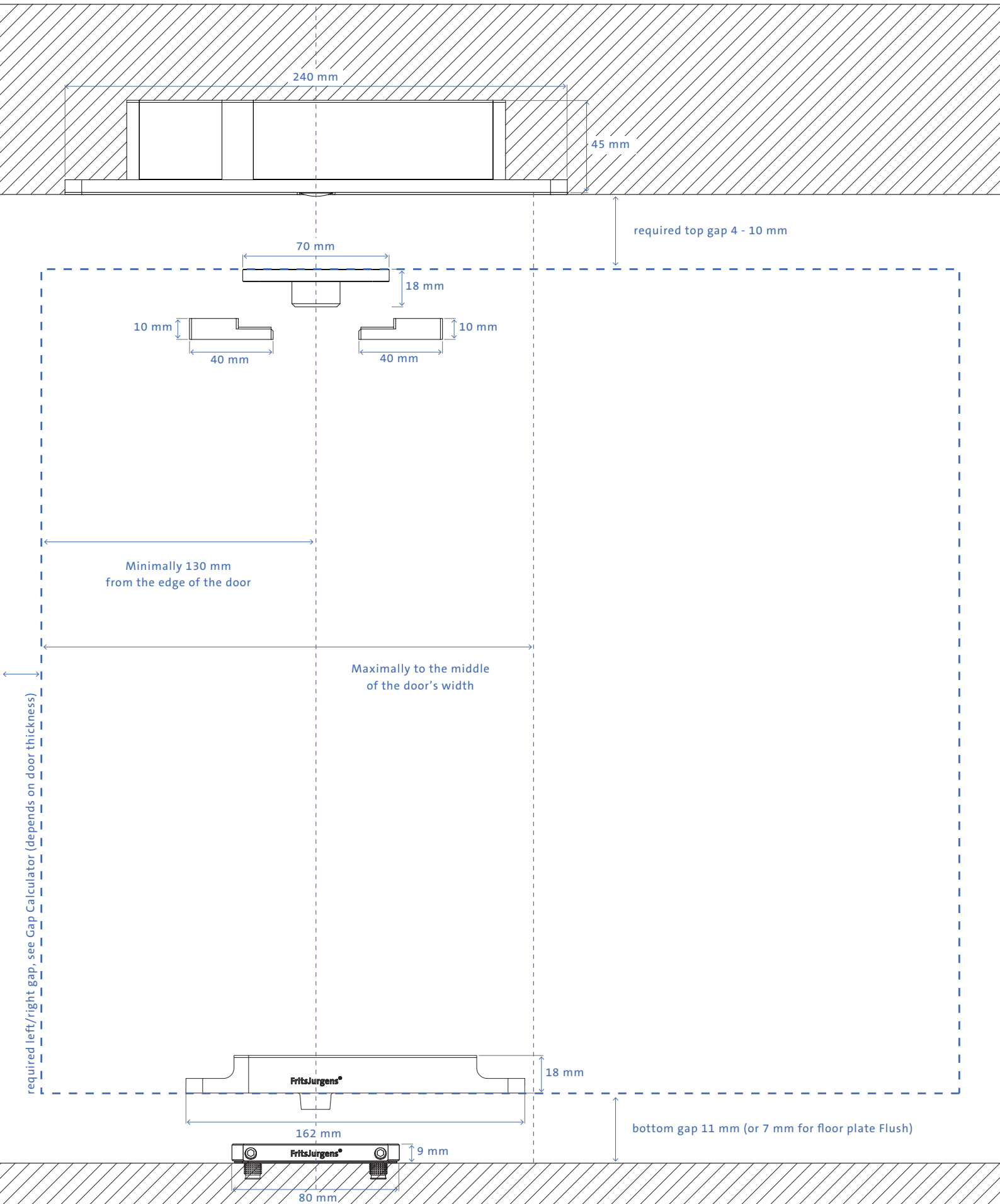

FritsJurgens®

FRITSJURGENS INTERNATIONAL

A. Einsteinlaan 1

9615 TE Kolham

The Netherlands

+31 598 343 410

info@fritsjurgens.com

Available in North America through

B ——— W

BRIDGEPORT WORLDWIDE

+1-800-362-1484

info@bridgeportworldwide.com

bridgeportworldwide.com/fritsjurgens

BO.tech.One.EN

Copyright © FritsJurgens®

31-05-2023



8 720681 609096

www.fritsjurgens.com