

It all hinges on excellence.

SIMONSWERK



TECTUS

The adjustable concealed door hinge

B — **W**

available in North America through Bridgeport Worldwide
T: +1-800-362-1484 — info@BridgeportWorldwide.com

Content

TECTUS – The adjustable concealed door hinge

		Load Capacity	Model versions from 60 to 300 kg (132 – 661 lbs.)
6	TE 240 3D	up to 60 kg (132 lbs.)	For flush residential doors
7	TE 340 3D	up to 80 kg (176 lbs.)	For flush residential and commercial doors
8	TE 526 3D	up to 120 kg (264 lbs.)	Manufactured of solid stainless steel for flush commercial doors
9	TE 527 3D	up to 120 kg (264 lbs.)	Manufactured of mild steel for flush commercial doors
10	TE 540 3D	up to 120 kg (264 lbs.)	For flush commercial doors
11	TE 640 3D	up to 200 kg (440 lbs.)	For flush high performance commercial doors
12	TE 645 3D	up to 300 kg (661 lbs.)	For flush high performance commercial doors

		Load Capacity	Model versions for special applications
17	TE 240 3D Energy Kit	up to 60 kg (132 lbs.)	With integrated and continuous energy transfer for flush doors
18	TE 340 3D Energy Kit	up to 80 kg (176 lbs.)	With integrated and continuous energy transfer for flush doors
19	TE 526 3D Energy Kit	up to 120 kg (264 lbs.)	With integrated and continuous energy transfer for flush doors
20	TE 527 3D Energy Kit	up to 120 kg (264 lbs.)	With integrated and continuous energy transfer for flush doors
21	TE 540 3D Energy Kit	up to 120 kg (264 lbs.)	With integrated and continuous energy transfer for flush doors
22	TE 640 3D Energy Kit	up to 200 kg (440 lbs.)	With integrated and continuous energy transfer for flush doors
23	TE 645 3D Energy Kit	up to 300 kg (661 lbs.)	With integrated and continuous energy transfer for flush doors
25	TE 541 3D FVZ	up to 100 kg (220 lbs.)	For flush residential and commercial doors with recessed frame facings
27	TE 540 3D A8	up to 100 kg (220 lbs.)	For flush doors with claddings up to 8 mm (0.315")
28	TE 640 3D A8	up to 160 kg (352 lbs.)	For flush doors with claddings up to 8 mm (0.315")
29	TE 626 3D A8	up to 300 kg (661 lbs.)	For flush doors with claddings up to 8 mm (0.315")
30	TE 540 3D A8 Energy Kit	up to 100 kg (220 lbs.)	For flush doors with claddings up to 8 mm (0.315")
31	TE 640 3D A8 Energy Kit	up to 160 kg (352 lbs.)	For flush doors with claddings up to 8 mm (0.315")
32	TE 626 3D A8 Energy Kit	up to 300 kg (661 lbs.)	For flush doors with claddings up to 8 mm (0.315")

		Cover Plates, Fixing Plates and Receivers
33	Cover Plates	Add-on item for frame and door prep
35	Receivers	Reinforcement for doors and frames for flush steel and stainless steel doors
41	Fixing Plates	For reinforcement of casing frames

44	Installation and Adjustment
48	Hinge Positions
49	Load Capacities
52	Finishes
53	General Information

The completely concealed hinge system

The **TECTUS** series of concealed hinges offers unsurpassed quality, versatility, and depth. This series features an entire range for architectural openings. The TECTUS hinge offers a “clean” look, which has not been matched by any other manufacturer.

The adjustment feature provides a simple way to create a perfect margin between the door and the frame. This enables the door to be adjusted in three dimensions (horizontal, vertical and in/out) by simply turning an Allen wrench. The refined visual appearance in combination with its maintenance-free slide bearings distinguishes TECTUS from all other concealed hinges.

The **TECTUS A8** versions allow a door to visually disappear into a wall with a variety of claddings such as mirrors, laminates, and marble.

Modern and efficient buildings of today often require the ability to control and operate doors remotely. This requires the transfer of electrical power and data/information from door frames to door panels. The **TECTUS Energy** series provides a sophisticated way to fulfill the requirement of this technology when card readers, access and door control systems, electrified locks, monitoring systems, and multimedia components are used. The cable, with its 16 wires, is completely concealed behind the hinge arms in order to avoid unauthorized tampering. The TECTUS Energy hinge is available in a wide variety to accommodate different door weights and applications.

TECTUS – The adjustable concealed door hinge

- For clean, flush architectural designs
- For load capacities of up to 300 kg (661 lbs.)
- For flush and rabbeted flush doors
- For wood, steel and aluminum doors and frames
- Ability to open door full 180 degrees
- With maintenance-free slide bearing technology



Design meets function

A full range of concealed hinges

SIMONSWERK provides a comprehensive concealed hinge product line, TECTUS, for a wide variety of applications. These applications include residential and commercial doors as well as heavy fire doors and soundproof doors.

The TECTUS series offers consistent characteristics throughout the entire product line, such as the visual appearance, functionality and adjustability. Durability is another key feature that the TECTUS series offers and is therefore not limited to low traffic door applications. The ease of installation and maintenance-free slide bearing technology distinguishes this product line. TECTUS hinges are available in 16 standard architectural finishes.



**TE 240 3D**

Load capacity
up to 60 kg (132 lbs.)

**TE 340 3D**

Load capacity
up to 80 kg (176 lbs.)

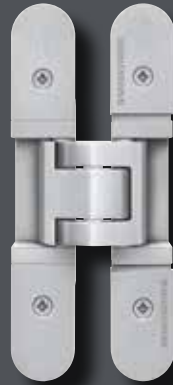
**TE 526 3D**

Load capacity
up to 120 kg (264 lbs.)

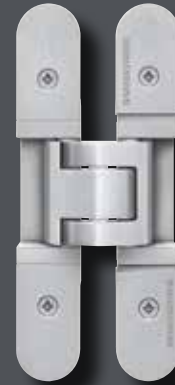
**TE 527 3D**

Load capacity
up to 120 kg (264 lbs.)

**TE 540 3D**

Load capacity
up to 120 kg (264 lbs.)

**TE 640 3D**

Load capacity
up to 200 kg (440 lbs.)

**TE 645 3D**

Load capacity
up to 300 kg (661 lbs.)

TECTUS

TE 240 3D

For flush residential doors

Hinge	up to 60 kg (132 lbs.)
--------------	-------------------------------

Product Features

- Completely concealed hinge system
- For wood, steel or aluminum door panels and frames
- For flush residential doors
- Finger protection due to a small gap between door and frame
- Easily adjustable in three dimensions (side +/- 3.0 mm (0.118"), height +/- 3.0 mm (0.118"), compression +/- 1.0 mm (0.039"))
- Maintenance-free slide bearings

The specification text can be downloaded from the PRODUCTSELECTOR at www.simonswerk-usa.com.

Technical Data

Load capacity	60 kg (132 lbs.)
Length	155 mm (6.102")
Width (door)	18 mm (0.709")
Width (frame)	21 mm (0.827")
Router bit / collar Ø	1/2" / 1"

Finishes

satin chrome look (F1) (124), satin nickel look (F2) (125), stainless steel look (SSL) (126), rustic umber (156), bronze metallic (168), traffic white (RAL 9016) (070), matte deep black (RAL 9005) (107), polished brass (030), polished nickel (038), satin nickel (144), satin chrome (146), bronze finish light (175), bronze finish (174), bronze finish dark (176), satin brass (047), other finishes available upon request

Combinations

Receiver / Reinforcement	Commercial frame	Frame mounted
	Casing frame	TE 240 3D FZ
	Steel frame	TE 240 3D SZ
	Steel door	TE 240 3D ST
	Aluminum frame	Specified by manufacturer

Installation Tools

Jig	Universal milling frame	
Frame	routing template	No. 5 251074 6
Door	routing template	No. 5 251075 6

Note

The load capacity mentioned above refers to the use of 2 hinges per door leaf with a height / width ratio of 2:1 (see page 46 for further detail).

For a minimum door panel thickness of 26 mm (1.024").

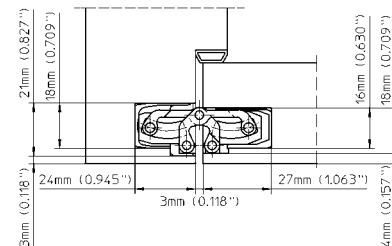
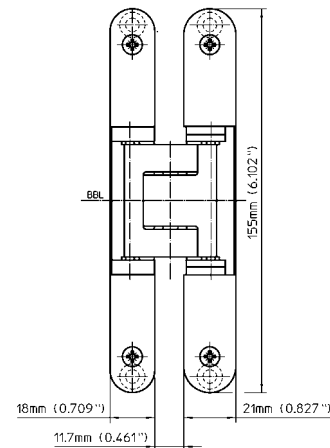

TECTUS

TE 340 3D

For flush residential and commercial doors

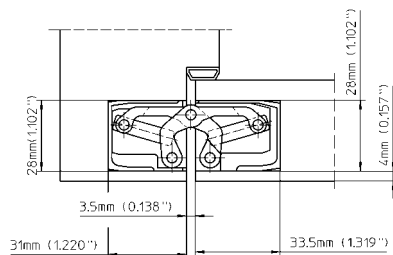
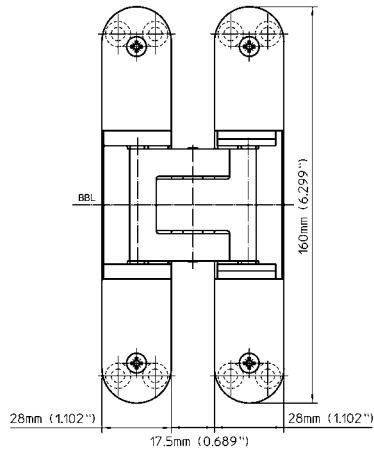

Hinge	up to 80 kg (176 lbs.)
-------	------------------------

Product Features

- Completely concealed hinge system
- For wood, steel or aluminum door panels and frames
- For flush residential and commercial doors
- Finger protection due to a small gap between door and frame
- Easily adjustable in three dimensions (side +/- 3.0 mm (0.118"), height +/- 3.0 mm (0.118"), compression +/- 1.0 mm (0.039"))
- Maintenance-free slide bearings
- UL listed for 20 minute fire door

The specification text can be downloaded from the PRODUCTSELECTOR at www.simonswerk-usa.com.

Technical Data

Load capacity	80 kg (176 lbs.)
Length	160 mm (6.299")
Width (door)	28 mm (1.102")
Width (frame)	28 mm (1.102")
Router bit/collar Ø	3/4" / 1"

Finishes

satin chrome look (F1) (124), satin nickel look (F2) (125), stainless steel look (SSL) (126), rustic umber (156), bronze metallic (168), traffic white (RAL 9016) (070), matte deep black (RAL9005) (107), polished brass (030), polished nickel (038), satin nickel (144), satin chrome (146), bronze finish light (175), bronze finish (174), bronze finish dark (176), satin brass (047), other finishes available upon request

Combinations

Receiver/Reinforcement	Commercial frame	Frame mounted
	Casing frame	TE 340 3D FZ
	Steel frame	TE 340 3D SZ
	Steel door	TE 340 3D ST
	Aluminum frame	Specified by manufacturer

Installation Tools

Jig	Universal milling frame
Step 1	routing template No. 5 251058 5
Step 2	routing template No. 5 251059 5

Application Range

Fire Resistant, Smoke Resistant, Forced Entry Resistant

Note

The load capacity mentioned above refers to the use of 2 hinges per door leaf with a height/width ratio of 2:1 (see page 46 for further detail).

For a minimum door panel thickness of 38 mm (1-1/2").

For fire rated doors: Check with door manufacturer regarding the usage of additional required intumescent material.

Square-corner cover plates are available upon request – see page 34.

TECTUS

TE 526 3D

Manufactured of solid stainless steel for flush commercial doors

Hinge up to 120 kg (264 lbs.)

Product Features

- Solid non-magnetic stainless steel (304 series) (marine grade 316 series upon request)
- Completely concealed hinge system
- For wood, steel or aluminum door panels and frames
- For flush commercial doors
- Easily adjustable in three dimensions (side +/- 3.0 mm (0.118"), height +/- 3.0 mm (0.118"), compression +/- 1.0 mm (0.039"))
- Maintenance-free slide bearings
- Finger protection due to a small gap between door and frame
- UL listed for 180 minute fire door

The specification text can be downloaded from the PRODUCTSELECTOR at www.simonswerk-usa.com.

Technical Data

Load capacity	120 kg (264 lbs.)
Length	155 mm (6.102")
Width (door)	26 mm (1.024")
Width (frame)	26 mm (1.024")
Router bit/collar Ø	3/4" / 1"

Finishes

satin stainless steel (304 series) (040)

Combinations

Receiver/Reinforcement	Commercial frame	Frame mounted
	Casing frame	TE 526 3D FZ
	Steel frame	TE 526 3D SZ
	Steel door	TE 526 3D ST
	Aluminum frame	Specified by manufacturer

Installation Tools

Jig	Universal milling frame Drilling jig TECTUS TE 526 3D
Frame/Door	routing template No. 5 251070 6

Application Range

Fire Resistant, Smoke Resistant, Soundproof, Forced Entry Resistant, High Corrosion Resistant

Note

The load capacity mentioned above refers to the use of 2 hinges per door leaf with a height/width ratio of 2:1 (see page 46 for further detail).

For a minimum door panel thickness of 34 mm (1-3/8").

For fire rated doors: Check with door manufacturer regarding the usage of additional required intumescent material.

Square-corner cover plates are available upon request – see page 34.

The load capacity may be reduced when installed in combination with a door closer.

For further information, please contact us.

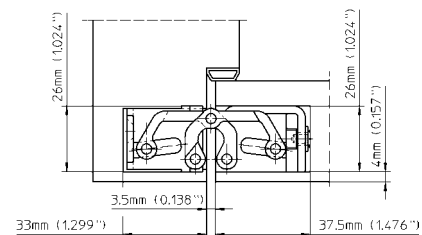
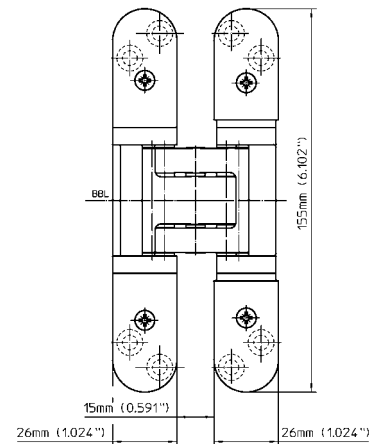

TECTUS

TE 527 3D

Manufactured of mild steel for flush commercial doors

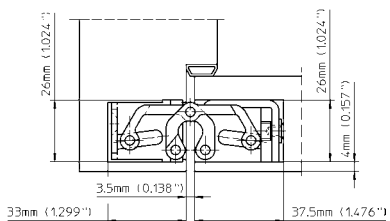
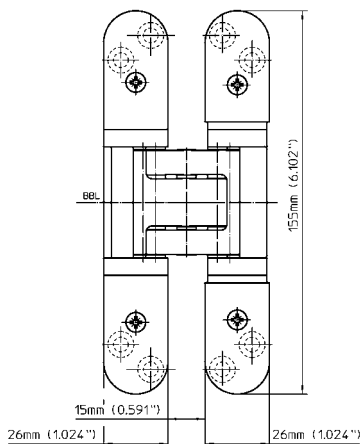

Hinge	up to 120 kg (264 lbs.)
--------------	--------------------------------

Product Features

- Mild steel
- Completely concealed hinge system
- For wood, steel or aluminum door panels and frames
- For flush commercial doors
- Easily adjustable in three dimensions (side +/- 3.0 mm (0.118"), height +/- 3.0 mm (0.118"), compression +/- 1.0 mm (0.039"))
- Maintenance-free slide bearings
- Finger protection due to a small gap between door and frame
- UL listed for 180 minute fire door

The specification text can be downloaded from the PRODUCTSELECTOR at www.simonswerk-usa.com.

Technical Data

Load capacity	120 kg (264 lbs.)
Length	155 mm (6.102")
Width (door)	26 mm (1.024")
Width (frame)	26 mm (1.024")
Router bit/collar Ø	3/4" / 1"

Finishes

stainless steel look (SSL) (126), other finishes available upon request

Combinations

Receiver/Reinforcement	Commercial frame	Frame mounted
	Casing frame	TE 527 3D FZ
	Steel frame	TE 527 3D SZ
	Steel door	TE 527 3D ST
	Aluminum frame	Specified by manufacturer

Installation Tools

Jig	Universal milling frame
	Drilling jig TECTUS TE 527 3D
Frame/Door	routing template No. 5 251070 6

Application Range

Fire Resistant, Smoke Resistant, Soundproof, Forced Entry Resistant

Note

The load capacity mentioned above refers to the use of 2 hinges per door leaf with a height/width ratio of 2:1 (see page 46 for further detail).
 For a minimum door panel thickness of 34 mm (1-3/8").
 For fire rated doors: Check with door manufacturer regarding the usage of additional required intumescent material.
 Square-corner cover plates are available upon request – see page 34.
 The load capacity may be reduced when installed in combination with a door closer.
 For further information, please contact us.

TECTUS

TE 540 3D

For flush commercial doors

Hinge	up to 120 kg (264 lbs.)
--------------	--------------------------------

Product Features

- Completely concealed hinge system
- For wood, steel or aluminum door panels and frames
- For flush commercial doors
- Finger protection due to a small gap between door and frame
- Easily adjustable in three dimensions (side +/- 3.0 mm (0.118"), height +/- 3.0 mm (0.118"), compression +/- 1.0 mm (0.039"))
- Maintenance-free slide bearings
- UL listed for 20 minute fire door

The specification text can be downloaded from the PRODUCTSELECTOR at www.simonswerk-usa.com.

Technical Data

Load capacity	120 kg (264 lbs.)
Length	200 mm (7.874")
Width (door)	32 mm (1.260")
Width (frame)	32 mm (1.260")
Router bit/collar Ø	3/4" / 1"

Finishes

satin chrome look (F1) (124), satin nickel look (F2) (125), stainless steel look (SSL) (126), rustic umber (156), bronze metallic (168), traffic white (RAL 9016) (070), matte deep black (RAL9005) (107), polished brass (030), polished nickel (038), satin nickel (144), satin chrome (146), bronze finish light (175), bronze finish (174), bronze finish dark (176), satin brass (047), other finishes available upon request

Combinations

Receiver/Reinforcement	Commercial frame	Frame mounted
	Casing frame	TE 540 3D FZ
	Steel frame	TE 540 3D SZ
	Steel door	TE 540 3D ST
	Aluminum frame	Specified by manufacturer

Installation Tools

Jig		Universal milling frame
Step 1	routing template	No. 5 251060 5
Step 2	routing template	No. 5 251061 5

Application Range

Fire Resistant, Smoke Resistant, Soundproof, Forced Entry Resistant

Note

The load capacity mentioned above refers to the use of 2 hinges per door leaf with a height/width ratio of 2:1 (see page 46 for further detail).
 For a minimum door panel thickness of 40 mm (1-5/8").
 For fire rated doors: Check with door manufacturer regarding the usage of additional required intumescent material.
 Square-corner cover plates are available upon request – see page 34.
 The load capacity may be reduced when installed in combination with a door closer.
 For further information, please contact us.

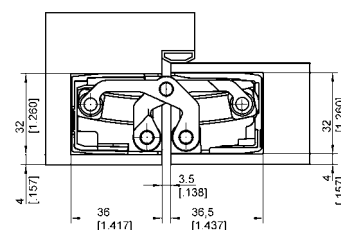
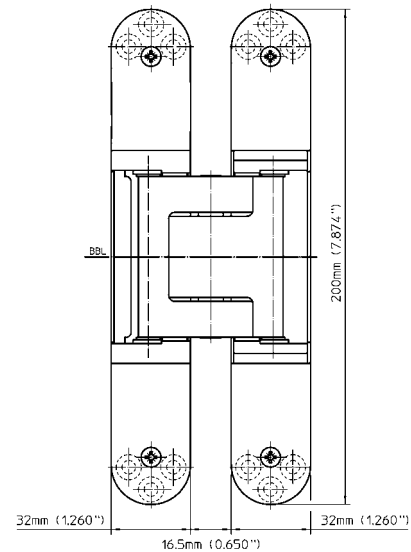

TECTUS

TE 640 3D

For flush high performance commercial doors



Hinge	up to 200 kg (440 lbs.)
--------------	--------------------------------

Product Features

- Completely concealed hinge system
- For wood, steel or aluminum door panels and frames
- For flush high performance commercial doors
- Finger protection due to a small gap between door and frame
- Easily adjustable in three dimensions (side +/- 3.0 mm (0.118"), height +/- 3.0 mm (0.118"), compression +/- 1.0 mm (0.039"))
- Maintenance-free slide bearings
- UL listed for 20 minute fire door

The specification text can be downloaded from the PRODUCTSELECTOR at www.simonswerk-usa.com.

Technical Data

Load capacity	200 kg (440 lbs.)
Length	240 mm (9.449")
Width (door)	32 mm (1.260")
Width (frame)	32 mm (1.260")
Router bit/collar Ø	3/4" / 1"

Finishes

satin chrome look (F1) (124), satin nickel look (F2) (125), stainless steel look (SSL) (126), rustic umber (156), bronze metallic (168), traffic white (RAL 9016) (070), matte deep black (RAL9005) (107), polished brass (030), polished nickel (038), satin nickel (144), satin chrome (146), bronze finish light (175), bronze finish (174), bronze finish dark (176), satin brass (047), other finishes available upon request

Combinations

Receiver/Reinforcement	Commercial frame	Frame mounted
	Casing frame	TE 640 3D FZ
	Steel frame	TE 640 3D SZ
	Steel door	TE 640 3D ST
	Aluminum frame	Specified by manufacturer
Mounting bracket		TE 640 3D BW/16
		TE 640 3D BW/20

Installation Tools

Jig		Universal milling frame
Step 1	routing template	No. 5 251062 5
Step 2	routing template	No. 5 251063 5

Application Range

Fire Resistant, Smoke Resistant, Soundproof, Forced Entry Resistant

Note

The load capacity mentioned above refers to the use of 2 hinges per door leaf with a height/width ratio of 2:1 (see page 46 for further detail).
 For a minimum door panel thickness of 40 mm (1-5/8").
 For fire rated doors: Check with door manufacturer regarding the usage of additional required intumescent material.
 Square-corner cover plates are available upon request – see page 34.
 The load capacity may be reduced when installed in combination with a door closer.
 For further information, please contact us.

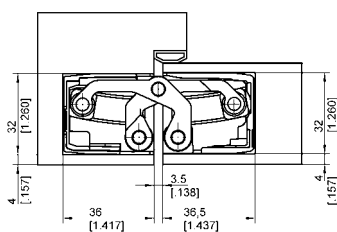
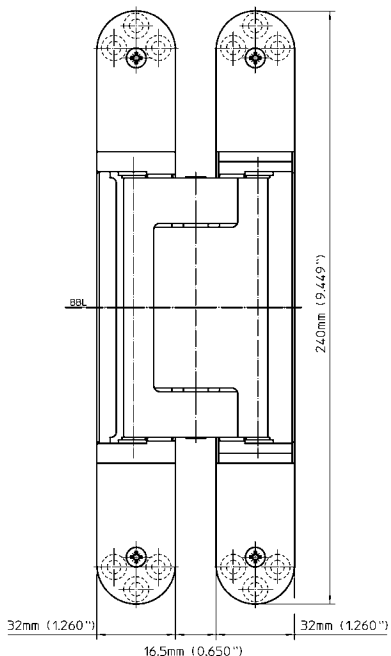

TECTUS

TE 645 3D

For flush high performance commercial doors

Hinge	up to 300 kg (661 lbs.)
--------------	--------------------------------

Product Features

- Completely concealed hinge system
- For wood, steel or aluminum door panels and frames
- For flush high performance commercial doors
- Finger protection due to a small gap between door and frame
- Easily adjustable in three dimensions (side +/- 3.0 mm (0.118"), height +/- 3.0 mm (0.118"), compression +/- 1.0 mm (0.039"))
- Maintenance-free slide bearings

The specification text can be downloaded from the PRODUCTSELECTOR at www.simonswerk-usa.com.

Technical Data

Load capacity	300 kg (661 lbs.)
Length (door)	260 mm (10.236")
Length (frame)	280 mm (11.024")
Width (door)	34 mm (1.339")
Width (frame)	36 mm (1.417")
Router bit/collar Ø	3/4" / 1"

Finishes

satin chrome look (F1) (124), stainless steel look (SSL) (126), other finishes available upon request

Combinations

Receiver/Reinforcement	Steel frame	TE 645 3D SZ
	Steel door	TE 645 3D ST

Installation Tools

Jig		Universal milling frame long
Frame, Step 1	routing template	No. 5 251064 5
Frame, Step 2	routing template	No. 5 251065 5
Door, Step 1	routing template	No. 5 251066 5
Door, Step 2	routing template	No. 5 251067 5

Application Range

Soundproof, Forced Entry Resistant

Note

The load capacity mentioned above refers to the use of 2 hinges per door leaf with a height/width ratio of 2:1 (see page 46 for further detail).

Use with a minimum door thickness of 44 mm (1-3/4"). Minimum door thickness of 51 mm (2") when used with steel frames.

Square-corner cover plates are available upon request – see page 34.

The load capacity may be reduced when installed in combination with a door closer. For further information, please contact us.

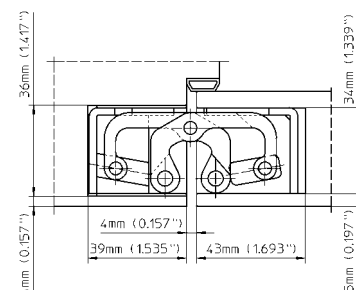
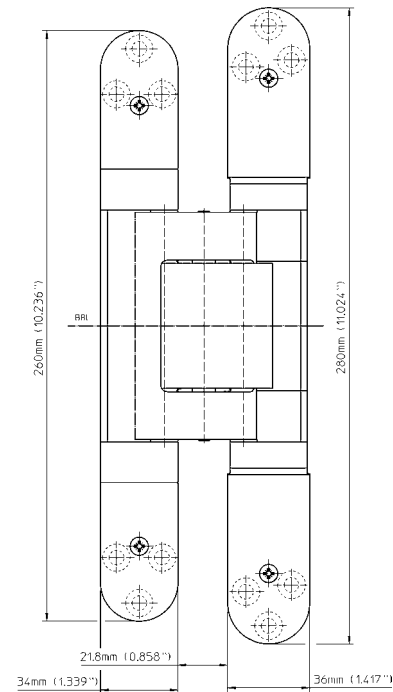



TECTUS – Versions for special applications

Special architectural planning tasks require individual solutions. The solutions presented here by SIMONSWERK complement the TECTUS product range.



TECTUS FVZ

Allows frame to be hidden and door to be flush with wall surfaces by using recessed frame up to 14 mm (0.551")

For load capacities up to 100 kg (220 lbs.)



TECTUS A8

Allows claddings on the door and frame up to 8 mm (5/16") thick

Door panel can be opened a full 180 degrees

3 sizes for load capacities up to 300 kg (661 lbs.)



TECTUS Energy

Load capacities of 60 kg (132 lbs.)
up to 300 kg (661 lbs.)

Round cable

Plug connector and open ended cable
Cable length: 3 m (9.8') or 10m (32.8')
16 wires with 0.8 A per wire
Up to 50 V
Wire gauge 0.14 square mm (26 AWG)



Universal adapter

Plug connector and direct screw
terminal block connector
3 x 3.2 A and 4 x 0.8 A power
Up to 50 V
Wire gauge 0.14 square mm (26 AWG)

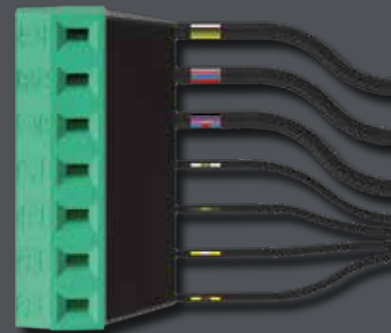

Custom adapters

Available upon request



TECTUS Energy

Integrated and continuous energy transfer

Today's modern and efficient buildings often require the ability to control and operate doors remotely. This requires the transfer of electrical power and information from door frames to door panels. The TECTUS Energy Series provides a sophisticated way to utilize this technology when card readers, access and door control systems, electrified locks, monitoring systems, and multimedia components are installed.

The cable, with its 16 wires, is completely concealed behind the hinge arms to prevent unauthorized tampering and has successfully passed a 1 million cycle test. The TECTUS Energy hinge is available in a variety of sizes to accommodate different door panel weights. Different adapters for simple reverse polarity protected plug connection are available.



Universal adapter

- compatible with most popular hardware components
- three different snap-fitting connectors (round cable, universal adapter, custom adapter)

Flat ribbon cable

- 16-wire ribbon cable
- integrated continuous energy transfer

Clip

- secure and reliable connection between cable and hinge housing

TECTUS

TE 240 3D Energy Kit

With integrated and continuous energy transfer for flush residential doors

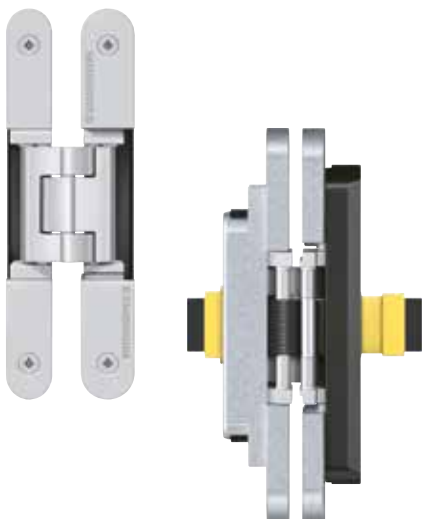

Hinge	energy transfer	up to 60 kg (132 lbs.)
--------------	------------------------	-------------------------------

Product Features

- Multiple connection adapter options
- Completely concealed hinge system
- For wood, steel or aluminum door panels and frames
- Easily adjustable in three dimensions (side +/- 3.0 mm (0.118"), height +/- 3.0 mm (0.118"), compression +/- 1.0 mm (0.039"))
- Maintenance-free slide bearings
- Finger protection due to a small gap between door and frame

The specification text can be downloaded from the PRODUCTSELECTOR at www.simonswerk-usa.com.

Technical Data

Load capacity	60 kg (132 lbs.)
Length	155 mm (6.102")
Width (door)	18 mm (0.709")
Width (frame)	21 mm (0.827")
Router bit/collar Ø	1/2" / 1"
No. of wires/Wire cross section	16/0.14 mm ²
Max. voltage	50 V (for voltages of 24 V or higher only with safeguarded power supply)
Max. current	0.8 A (per wire)

Finishes

satin chrome look (F1) (124), stainless steel look (SSL) (126), other finishes available upon request

Combinations

Receiver/Reinforcement	Commercial frame	Frame mounted
	Casing frame	TE 240 3D FZ
	Steel frame	TE 240 3D SZ
	Steel door	TE 240 3D ST
	Aluminum frame	Specified by manufacturer

Accessories	Round Cable 10m (393.701")
	Custom Adapter

Installation Tools (in addition to templates for standard versions)

Routing for raceway	routing template	No. 5 251081 5
---------------------	------------------	----------------

Note

The load capacity mentioned above refers to the use of 2 hinges per door leaf with a height/width ratio of 2:1 (see page 46 for further detail).
 For a minimum door panel thickness of 26 mm (1.024").
 Kit includes two 3 m (118.110") round cables.

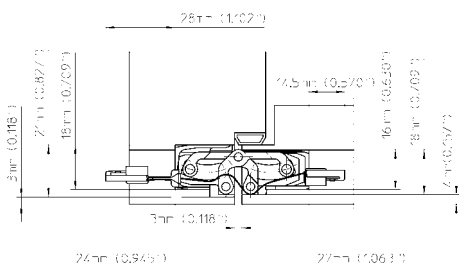
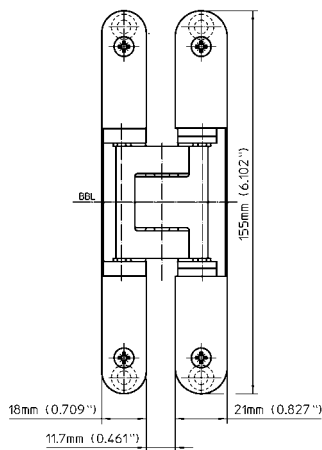

TECTUS

TE 340 3D Energy Kit

With integrated and continuous energy transfer for flush residential doors

Hinge	energy transfer	up to 80 kg (176 lbs.)
--------------	------------------------	-------------------------------

Product Features

- Multiple connection adapter options
- Completely concealed hinge system
- For wood, steel or aluminum door panels and frames
- Easily adjustable in three dimensions (side +/- 3.0 mm (0.118"), height +/- 3.0 mm (0.118"), compression +/- 1.0 mm (0.039"))
- Maintenance-free slide bearings
- Finger protection due to a small gap between door and frame
- UL listed for 20 minute fire door

The specification text can be downloaded from the PRODUCTSELECTOR at www.simonswerk-usa.com.

Technical Data

Load capacity	80 kg (176 lbs.)
Length	160 mm (6.299")
Width (door)	28 mm (1.102")
Width (frame)	28 mm (1.102")
Router bit/collar Ø	3/4" / 1"
No. of wires/Wire cross section	16/0.14 mm ²
Max. voltage	50 V (for voltages of 24 V or higher only with safeguarded power supply)
Max. current	0.8 A (per wire)

Finishes

satin chrome look (F1) (124), stainless steel look (SSL) (126), other finishes available upon request

Combinations

Receiver/Reinforcement	Commercial frame	Frame mounted
	Casing frame	TE 340 3D FZ
	Steel frame	TE 340 3D SZ
	Steel door	TE 340 3D ST
	Aluminum frame	Specified by manufacturer
Accessories	Round Cable 10m (393.701") Custom Adapter	

Installation Tools (in addition to templates for standard versions)

Routing for raceway	routing template	No. 5 251082 5
---------------------	------------------	----------------

Application Range

Fire Resistant, Smoke Resistant, Forced Entry Resistant

Note

The load capacity mentioned above refers to the use of 2 hinges per door leaf with a height/width ratio of 2:1 (see page 46 for further detail).
For a minimum door panel thickness of 38 mm (1-1/2").
For fire rated doors: Check with door manufacturer regarding the usage of additional required intumescent material.
Square-corner cover plates are available upon request – see page 34.
Please specify accessories when ordering.
Kit includes two 3 m (118.110") round cables.

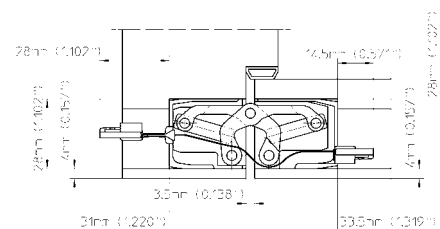
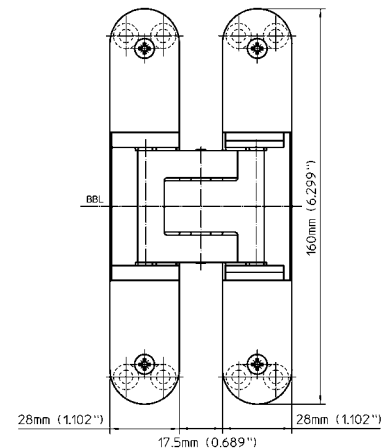
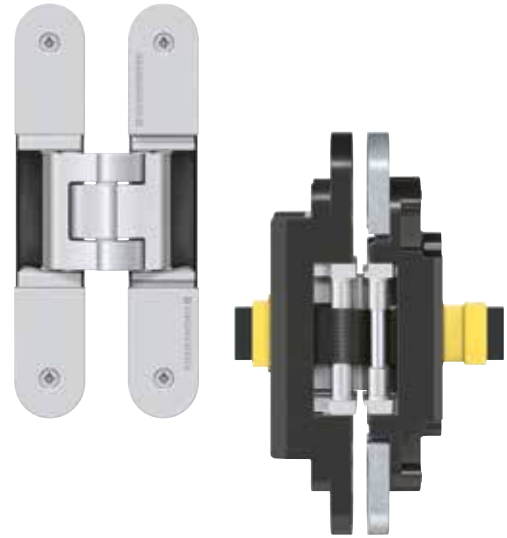

TECTUS

TE 526 3D Energy Kit

Manufactured of solid stainless steel with integrated and continuous energy transfer for flush commercial doors



Hinge	energy transfer	up to 120 kg (264 lbs.)
--------------	------------------------	--------------------------------

Product Features

- Multiple connection adapter options
- Solid non-magnetic stainless steel (304 series) (marine grade 316 series upon request)
- Completely concealed hinge system
- For wood, steel or aluminum door panels and frames
- Easily adjustable in three dimensions (side +/- 3.0 mm (0.118"), height +/- 3.0 mm (0.118"), compression +/- 1.0 mm (0.039"))
- Maintenance-free slide bearings
- UL listed for 20 minute fire door

The specification text can be downloaded from the PRODUCTSELECTOR at www.simonswerk-usa.com.

Technical Data

Load capacity	120 kg (264 lbs.)
Length	155 mm (6.102")
Width (door/frame)	26 mm (1.024")
Router bit/collar Ø	3/4" / 1"
No. of wires/Wire cross section	16/0.14 mm ²
Max. voltage	50 V (for voltages of 24 V or higher only with safeguarded power supply)
Max. current	0.8 A (per wire)

Finishes

satin stainless steel (040)

Combinations

Receiver/Reinforcement	Commercial frame	Frame mounted
	Casing frame	TE 526 3D FZ
	Steel frame	TE 526 3D SZ
	Steel door	TE 526 3D ST
	Aluminum frame	Specified by manufacturer

Accessories	Round Cable 10m (393.701")	Custom Adapter
-------------	----------------------------	----------------

Installation Tools (in addition to templates for standard versions)

Routing for raceway	routing template	No. 5 251082 5
---------------------	------------------	----------------

Application Range

Fire Resistant, Smoke Resistant, Soundproof, Forced Entry Resistant, High Corrosion Resistant

Note

The load capacity mentioned above refers to the use of 2 hinges per door leaf with a height/width ratio of 2:1 (see page 46 for further detail).
 For a minimum door panel thickness of 34 mm (1-3/8").
 For fire rated doors: Check with door manufacturer regarding the usage of additional required intumescent material.
 Square-corner cover plates are available upon request – see page 34.
 Kit includes two 3 m (118.110") round cables.

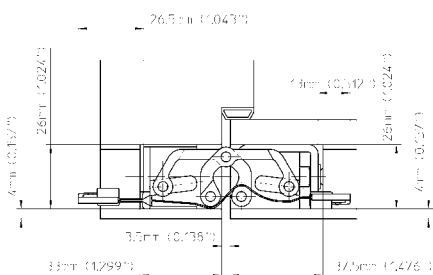
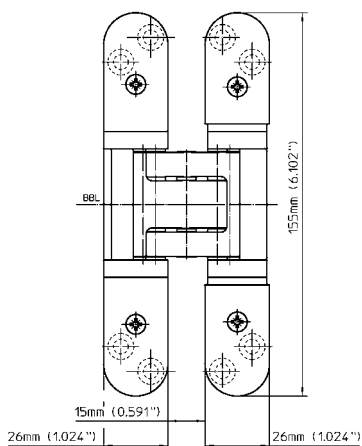

TECTUS

TE 527 3D Energy Kit

Manufactured of mild steel with integrated and continuous energy transfer for flush commercial doors

Hinge	energy transfer	up to 120 kg (264 lbs.)
--------------	------------------------	--------------------------------

Product Features

- Multiple connection adapter options
- Mild steel
- Completely concealed hinge system
- For wood, steel or aluminum door panels and frames
- Easily adjustable in three dimensions (side +/- 3.0 mm (0.118"), height +/- 3.0 mm (0.118"), compression +/- 1.0 mm (0.039"))
- Maintenance-free slide bearings
- UL listed for 20 minute fire door

The specification text can be downloaded from the PRODUCTSELECTOR at www.simonswerk-usa.com.

Technical Data

Load capacity	120 kg (264 lbs.)
Length	155 mm (6.102")
Width (door/frame)	26 mm (1.024")
Router bit/collar Ø	3/4" / 1"
No. of wires/Wire cross section	16/0.14 mm ²
Max. voltage	50 V (for voltages of 24 V or higher only with safeguarded power supply)
Max. current	0.8 A (per wire)

Finishes

stainless steel look (SSL) (126), other finishes available upon request

Combinations

Receiver/Reinforcement	Commercial frame	Frame mounted
	Casing frame	TE 527 3D FZ
	Steel frame	TE 527 3D SZ
	Steel door	TE 527 3D ST
	Aluminum frame	Specified by manufacturer
Accessories	Round Cable 10m (393.701") Custom Adapter	

Installation Tools (in addition to templates for standard versions)

Routing for raceway	routing template	No. 5 251082 5
---------------------	------------------	----------------

Application Range

Fire Resistant, Smoke Resistant, Soundproof, Forced Entry Resistant, High Corrosion Resistant

Note

The load capacity mentioned above refers to the use of 2 hinges per door leaf with a height/width ratio of 2:1 (see page 46 for further detail).
For a minimum door panel thickness of 34 mm (1-3/8").
For fire rated doors: Check with door manufacturer regarding the usage of additional required intumescent material.
Square-corner cover plates are available upon request – see page 34.
Kit includes two 3 m (118.110") round cables.

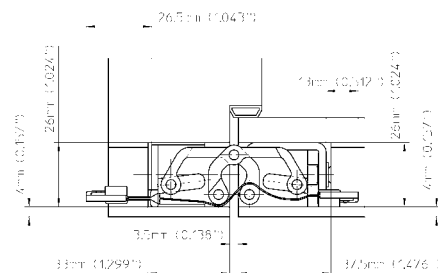
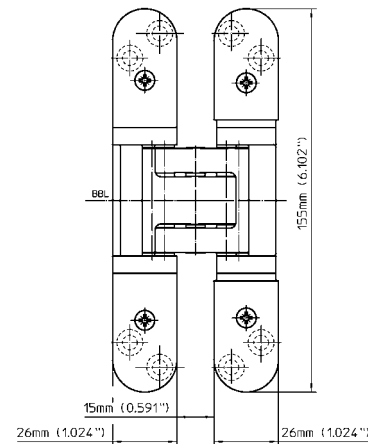

TECTUS

TE 540 3D Energy Kit

With integrated and continuous energy transfer for flush commercial doors



Hinge	energy transfer	up to 120 kg (264 lbs.)
-------	-----------------	-------------------------

Product Features

- Multiple connection adapter options
- Completely concealed hinge system
- For wood, steel or aluminum door panels and frames
- Easily adjustable in three dimensions (side +/- 3.0 mm (0.118"), height +/- 3.0 mm (0.118"), compression +/- 1.0 mm (0.039"))
- Maintenance-free slide bearings
- UL listed for 20 minute fire door

The specification text can be downloaded from the PRODUCTSELECTOR at www.simonswerk-usa.com.

Technical Data

Load capacity	120 kg (264 lbs.)
Length	200 mm (7.874")
Width (door)	32 mm (1.260")
Width (frame)	32 mm (1.260")
Router bit/collar Ø	3/4" / 1"
No. of wires/Wire cross section	16/0.14 mm²
Max. voltage	50 V (for voltages of 24 V or higher only with safeguarded power supply)
Max. current	0.8 A (per wire)

Finishes

satin chrome look (F1) (124), stainless steel look (SSL) (126), other finishes available upon request

Combinations

Receiver/Reinforcement	Commercial frame	Frame mounted
	Casing frame	TE 540 3D FZ
	Steel frame	TE 540 3D SZ
	Steel door	TE 540 3D ST
	Aluminum frame	Specified by manufacturer

Accessories	Round Cable 10m (393.701")
	Custom Adapter

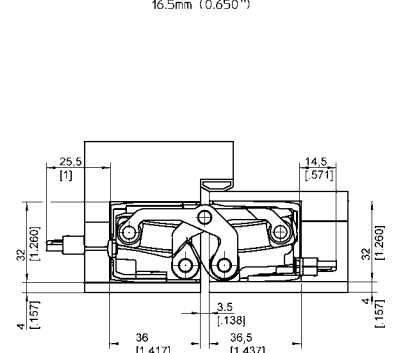
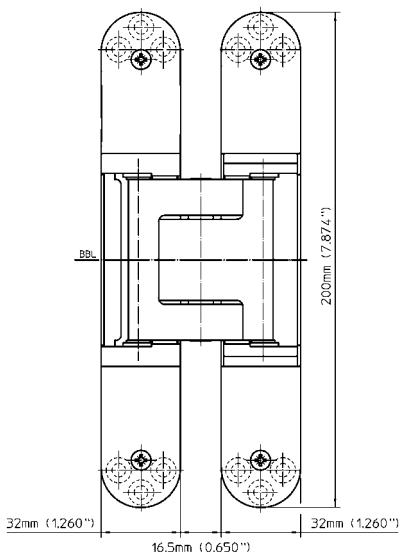

Installation Tools (in addition to templates for standard versions)

Routing for raceway	routing template	No. 5 251082 5
---------------------	------------------	----------------

Application Range

Fire Resistant, Smoke Resistant, Soundproof, Forced Entry Resistant

Note

The load capacity mentioned above refers to the use of 2 hinges per door leaf with a height/width ratio of 2:1 (see page 46 for further detail).
 For a minimum door panel thickness of 40 mm (1-5/8").
 For fire rated doors: Check with door manufacturer regarding the usage of additional required intumescent material.
 Square-corner cover plates are available upon request – see page 34.
 Kit includes two 3 m (118.110") round cables.



TECTUS

TE 640 3D Energy Kit

With integrated and continuous energy transfer for flush high performance commercial doors

Hinge	energy transfer	up to 200 kg (440 lbs.)
--------------	------------------------	--------------------------------

Product Features

- Multiple connection adapter options
- Completely concealed hinge system
- For wood, steel or aluminum door panels and frames
- Easily adjustable in three dimensions (side +/- 3.0 mm (0.118"), height +/- 3.0 mm (0.118"), compression +/- 1.0 mm (0.039"))
- Maintenance-free slide bearings
- UL listed for 20 minute fire door

The specification text can be downloaded from the PRODUCTSELECTOR at www.simonswerk-usa.com.

Technical Data

Load capacity	200 kg (440 lbs.)
Length	240 mm (9.449")
Width (door)	32 mm (1.260")
Width (frame)	32 mm (1.260")
Router bit / collar Ø	3/4" / 1"
No. of wires / Wire cross section	16 / 0.14 mm ²
Max. voltage	50 V (for voltages of 24 V or higher only with safeguarded power supply)
Max. current	0.8 A (per wire)

Finishes

satin chrome look (F1) (124), stainless steel look (SSL) (126), other finishes available upon request

Combinations

Receiver / Reinforcement	Commercial frame	Frame mounted
	Casing frame	TE 640 3D FZ
	Steel frame	TE 640 3D SZ
	Steel door	TE 640 3D ST
	Aluminum frame	Specified by manufacturer
Accessories	Round Cable 10m (393.701") Custom Adapter	

Installation Tools (in addition to templates for standard versions)

Routing for raceway	routing template	No. 5 251082 5
---------------------	------------------	----------------

Application Range

Fire Resistant, Smoke Resistant, Soundproof, Forced Entry Resistant

Note

The load capacity mentioned above refers to the use of 2 hinges per door leaf with a height / width ratio of 2:1 (see page 46 for further detail).

For a minimum door panel thickness of 40 mm (1-5/8").

For fire rated doors: Check with door manufacturer regarding the usage of additional required intumescent material.

Square-corner cover plates are available upon request – see page 34.

Kit includes two 3 m (118.110") round cables.

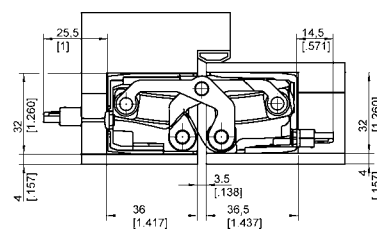
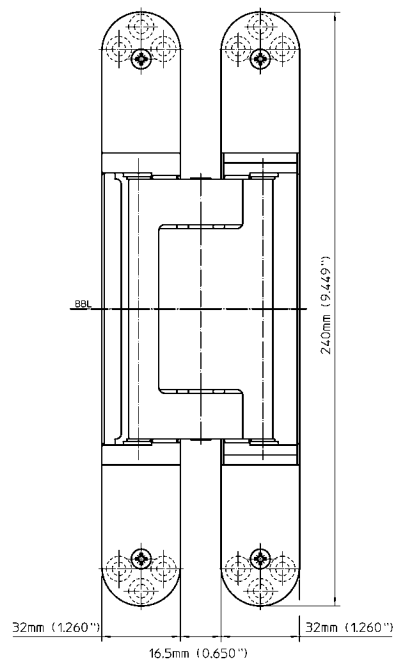
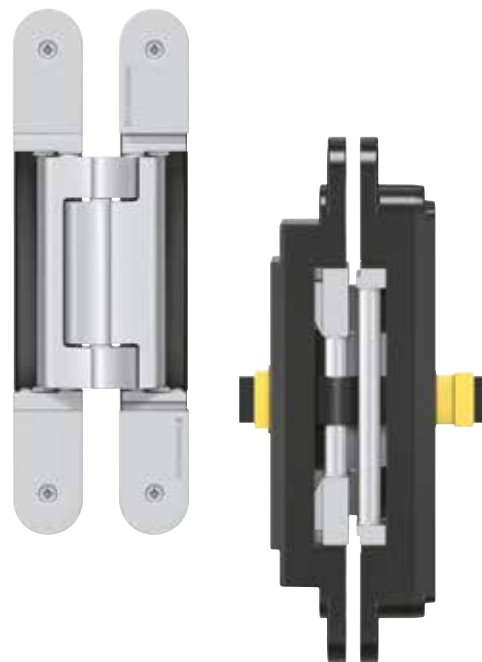

TECTUS

TE 645 3D Energy Kit

With integrated and continuous energy transfer for flush high performance commercial doors

Hinge	energy transfer	up to 300 kg (661 lbs.)
--------------	------------------------	--------------------------------

Product Features

- Multiple connection adapter options
- Completely concealed hinge system
- For wood, steel or aluminum door panels and frames
- Easily adjustable in three dimensions (side +/- 3.0 mm (0.118"), height +/- 3.0 mm (0.118"), compression +/- 1.0 mm (0.039"))
- Maintenance-free slide bearings

The specification text can be downloaded from the PRODUCTSELECTOR at www.simonswerk-usa.com.

Technical Data

Load capacity	300 kg (661 lbs.)
Length (door)	260 mm (10.236")
Length (frame)	280 mm (11.024")
Width (door)	34 mm (1.339")
Width (frame)	36 mm (1.417")
Router bit/collar Ø	3/4" / 1"
No. of wires/Wire cross section	16/0.14 mm ²
Max. voltage	50 V (for voltages of 24 V or higher only with safeguarded power supply)
Max. current	0.8 A (per wire)

Finishes

satin chrome look (F1) (124), stainless steel look (SSL) (126), other finishes available upon request

Combinations

Receiver/Reinforcement	Steel frame	TE 645 3D SZ
	Steel door	TE 645 3D ST
Accessories	Round Cable 10m (393.701") Custom Adapter	

Installation Tools (in addition to templates for standard versions)

Routing for raceway	routing template	No. 5 251082 5
---------------------	------------------	----------------

Application Range

Soundproof, Forced Entry Resistant

Note

The load capacity mentioned above refers to the use of 2 hinges per door leaf with a height/width ratio of 2:1 (see page 46 for further detail).

Use with a minimum door thickness of 44 mm (1-3/4"), but can also be used with higher thicknesses.

Minimum door thickness of 51 mm (2") when used with steel frames.

Square-corner cover plates are available upon request – see page 34.

Kit includes two 3 m (118.110") round cables.

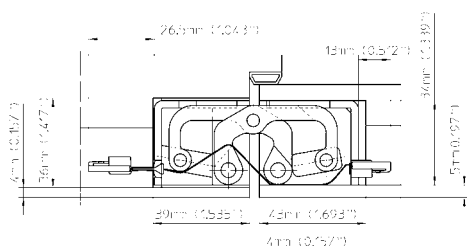
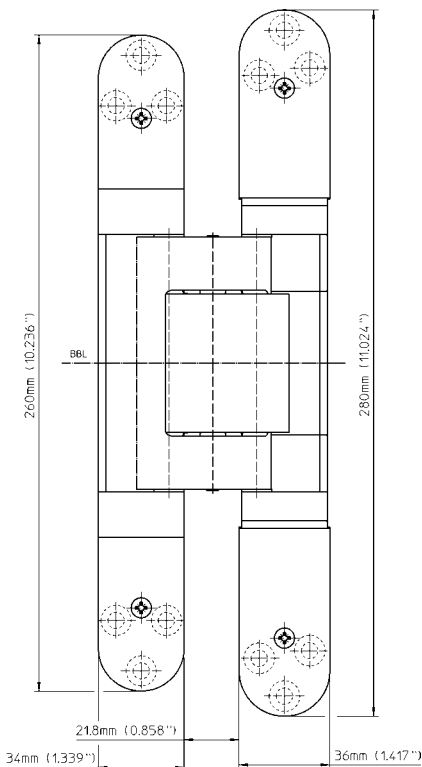
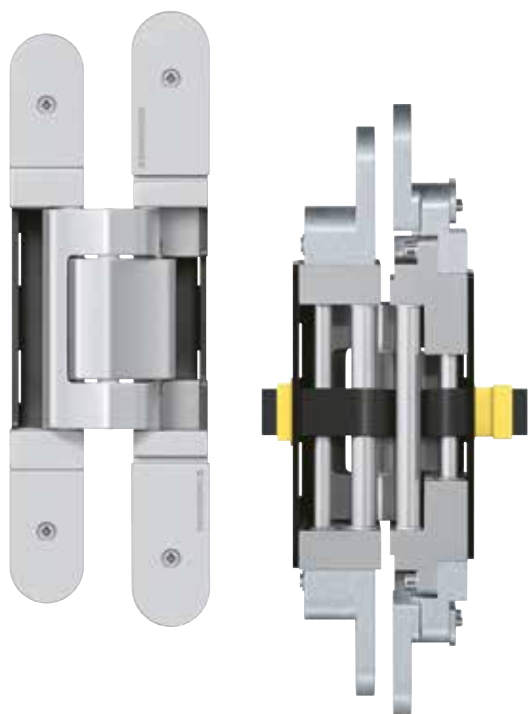

TECTUS FVZ

Door assemblies with hidden frames

The concealed TECTUS TE 541 3D FVZ hinge allows the frame to be recessed inside a finished wall for a door that is flush with the wall's surface. Due to the capability that the entire frame face can be covered with solid materials such as 1/2" drywall, rather than a single layer of plaster, the issue of surface cracking has been eliminated.

The frame facing can be recessed up to 14 mm (0.551") creating even more architectural possibilities for straight-lined, flush surface interior design. These hinges present a stunning architectural integration of door and wall elements. This hinge has the same amenities as existing models of the product brand TECTUS.

Load capacity up to
100 kg (220 lbs.)



For 14 mm (0.551")

- recessed frame facings

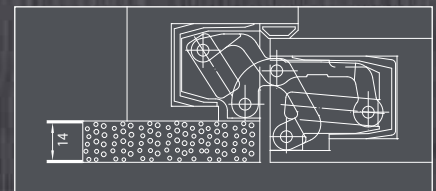

TECTUS

TE 541 3D FVZ

For flush residential and commercial doors with recessed frame facings



Hinge up to **100 kg (220 lbs.)**

Product Features

- FVZ = for 14.0 mm (0.551") recessed frame facings
- Completely concealed hinge system
- For wood, steel or aluminum door panels and frames
- For flush residential and commercial doors
- Finger protection due to a small gap between door and frame
- Easily adjustable in three dimensions (side +/- 3.0 mm (0.118"), height +/- 3.0 mm (0.118"), compression +/- 1.0 mm (0.039"))
- Maintenance-free slide bearings

The specification text can be downloaded from the PRODUCTSELECTOR at www.simonswerk-usa.com.

Technical Data

Load capacity	100 kg (220 lbs.)
Length	185 mm (7.283")
Width (door)	28 mm (1.102")
Width (frame)	28 mm (1.102")
Router bit/collar Ø	3/4" / 1"

Finishes

satin chrome look (F1) (124), satin nickel look (F2) (125), stainless steel look (SSL) (126), rustic umber (156), bronze metallic (168), traffic white (RAL 9016) (070), matte deep black (RAL9005) (107), polished brass (030), polished nickel (038), satin nickel (144), satin chrome (146), bronze finish light (175), bronze finish (174), bronze finish dark (176), satin brass (047), other finishes available upon request

Combinations

Receiver/Reinforcement	Casing frame	TE 541 3D FVZ FZ
	Steel frame	TE 541 3D FVZ SZ
	Steel door	TE 541 3D FVZ ST

Installation Tools

Jig	Universal milling frame	
Frame, Step 1	routing template	No. 5 251071 5
Frame, Step 2	routing template	No. 5 251072 5
Frame, Step 3	routing template	No. 5 251068 5
Door, Step 1	routing template	No. 5 251071 5
Door, Step 2	routing template	No. 5 251072 5
Door, Step 3	routing template	No. 5 251073 5

Application Range

Soundproof

Note

The load capacity mentioned above refers to the use of 2 hinges per door leaf with a height/width ratio of 2:1 (see page 46 for further detail).

Typical use with door thickness of 44 mm (1-3/4"), but can also be used with higher thicknesses.

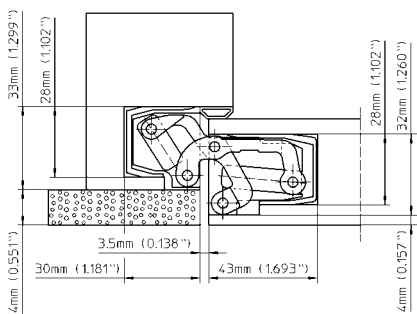
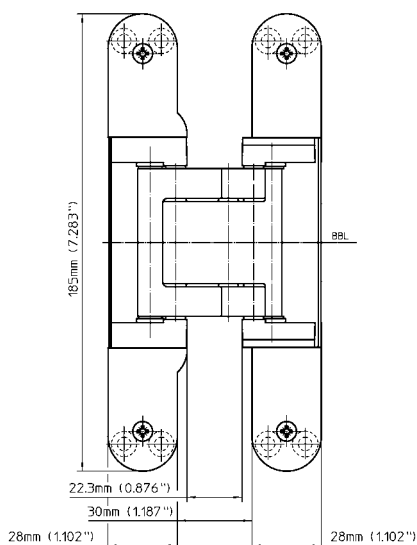

TECTUS A8

Cladding over the door and frame

The TECTUS A8 versions offer concealed hinges for applications where in the past it was only possible to use pivots to hang a door. The A8 versions allow a door to visually disappear into a wall with many a variety kinds of claddings

includes mirrors, laminates and marble up to 8 mm (0.315") in thickness. The TECTUS A8 hinges give designers new opportunities for integrating the door panel into a holistic room concept.

Load capacities up to
300 kg (661 lbs.)



For claddings up to 8 mm
(0.315") on door and frame

The use of different
cladding materials such as
wood, glass, etc. enables the
door to visually disappear
within a wall.

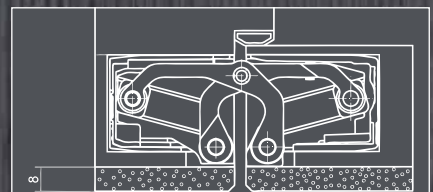

TECTUS

TE 540 3D A8

For flush commercial doors with claddings up to 8 mm (0.315")

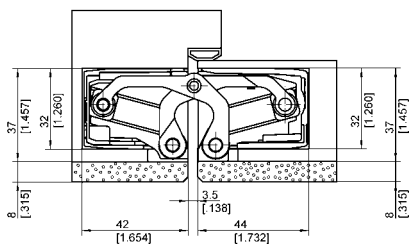
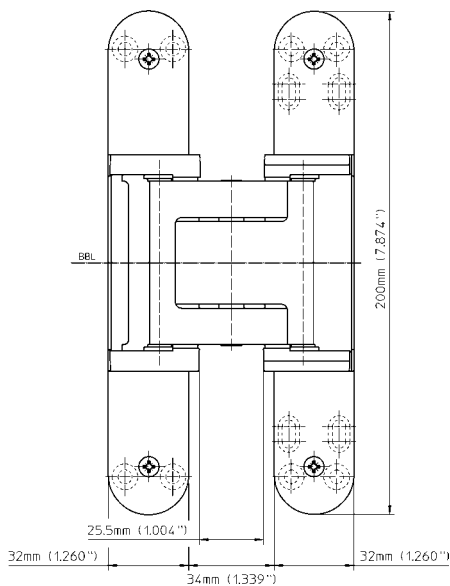

Hinge		up to 100 kg (220 lbs.)
-------	--	--------------------------------

Product Features

- Completely concealed hinge system
- For wood, steel or aluminum door panels and frames
- Easily adjustable in three dimensions (side +/- 3.0 mm (0.118"), height +/- 3.0 mm (0.118"), compression +/- 1.0 mm (0.039"))
- Maintenance-free slide bearings
- UL listed for 20 minute fire door

The specification text can be downloaded from the PRODUCTSELECTOR at www.simonswerk-usa.com.

Technical Data

Load capacity	100 kg (220 lbs.)
Length	200 mm (7.874")
Width (door)	per 32/37 mm (1.260/1.457")
Width (frame)	per 32/37 mm (1.260/1.457")
Router bit/collar Ø	3/4" / 1"

Finishes

satin chrome look (F1) (124), satin nickel look (F2) (125), stainless steel look (SSL) (126), rustic umber (156), bronze metallic (168), traffic white (RAL 9016) (070), matte deep black (RAL9005) (107), polished brass (030), polished nickel (038), satin nickel (144), satin chrome (146), bronze finish light (175), bronze finish (174), bronze finish dark (176), satin brass (047), other finishes available upon request

Combinations

Receiver/Reinforcement	Commercial frame	Frame mounted
	Casing frame	TE 540 3D FZ
	Steel frame	TE 540 3D A8 SZ
	Steel door	TE 540 3D A8 ST
	Aluminum frame	Specified by manufacturer

Installation Tools

Jig		Universal milling frame
Step 1	routing template	No. 5 251060 5
Step 2	routing template	No. 5 251061 5
Step 3	routing template	No. 5 251068 5
Step 3 (without cladding)	routing template	No. 5 251096 5

Application Range

Fire Resistant, Smoke Resistant, Soundproof, Forced Entry Resistant

Note

The load capacity mentioned above refers to the use of 2 hinges per door leaf with a height/width ratio of 2:1 (see page 46 for further detail).

For a minimum door panel thickness of 40 mm (1-5/8" plus cladding).

Fire rated doors: Check with door manufacturer regarding the usage of additional required intumescent material.

Cover plates for doors without cladding are available upon request – see page 33.

Square-corner cover plates are available upon request – see page 34.

TECTUS

TE 640 3D A8

For flush high performance commercial doors with claddings up to 8 mm (0.315")

Hinge up to 160 kg (352 lbs.)

Product Features

- Completely concealed hinge system
- For wood, steel or aluminum door panels and frames
- Easily adjustable in three dimensions (side +/- 3.0 mm (0.118"), height +/- 3.0 mm (0.118"), compression +/- 1.0 mm (0.039"))
- Maintenance-free slide bearings
- UL listed for 20 minute fire door

The specification text can be downloaded from the PRODUCTSELECTOR at www.simonswerk-usa.com.

Technical Data

Load capacity	160 kg (352 lbs.)
Length	240 mm (9.449")
Width (door)	32/37 mm (1.260/1.457")
Width (frame)	32/37 mm (1.260/1.457")
Router bit/collar Ø	3/4" / 1"

Finishes

satin chrome look (F1) (124), satin nickel look (F2) (125), stainless steel look (SSL) (126), rustic umber (156), bronze metallic (168), traffic white (RAL 9016) (070), matte deep black (RAL9005) (107), polished brass (030), polished nickel (038), satin nickel (144), satin chrome (146), bronze finish light (175), bronze finish (174), bronze finish dark (176), satin brass (047), other finishes available upon request

Combinations

Receiver/Reinforcement	Commercial frame	Frame mounted
	Casing frame	TE 640 3D FZ
	Steel frame	TE 640 3D A8 SZ
	Steel door	TE 640 3D A8 ST
	Aluminum frame	Specified by manufacturer
Mounting bracket	TE 640 3D A8 BW/1	

Installation Tools

Jig	Universal milling frame	
Step 1	routing template	No. 5 251062 5
Step 2	routing template	No. 5 251063 5
Step 3	routing template	No. 5 251069 5
Step 3 (without cladding)	routing template	No. 5 251095 5

Application Range

Fire Resistant, Smoke Resistant, Soundproof, Forced Entry Resistant

Note

The load capacity mentioned above refers to the use of 2 hinges per door leaf with a height/width ratio of 2:1 (see page 46 for further detail).

For a minimum door panel thickness of 40 mm (1-5/8" plus cladding).

Fire rated doors: Check with door manufacturer regarding the usage of additional required intumescent material.

Cover plates for doors without cladding are available upon request – see page 33.

Square-corner cover plates are available upon request – see page 34.

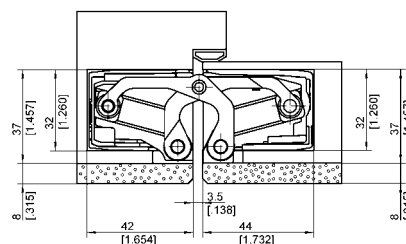
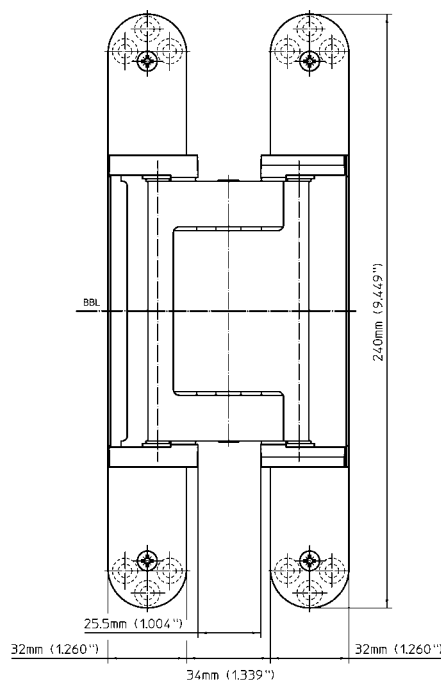

TECTUS

TE 626 3D A8

Manufactured of solid stainless steel for flush high performance commercial doors with claddings up to 8 mm (0.315")

Hinge **up to 300 kg (661 lbs.)**



Product Features

- Claddings up to 8 mm (0.315")
- Solid non-magnetic stainless steel (304 series)
- Completely concealed hinge system
- For wood, steel or aluminum door panels and frames
- Easily adjustable in three dimensions (side +/- 3.0 mm (0.118"), height +/- 3.0 mm (0.118"), compression +/- 1.0 mm (0.039"))
- Maintenance-free slide bearings
- UL listed for 180 minute fire door

The specification text can be downloaded from the PRODUCTSELECTOR at www.simonswerk-usa.com.

Technical Data

Load capacity	300 kg (661 lbs.)
Length	240 mm (9.449")
Width (door)	32 mm (1.260")
Width (frame)	32 mm (1.260")
Router bit/collar Ø	3/4" / 1"

Finishes

satin stainless steel (304 series) (040), other finishes available upon request

Combinations

Receiver/Reinforcement	Commercial frame	Frame mounted
	Casing frame	TE 626 3D A8 FZ
	Steel frame	TE 626 3D A8 SZ
	Steel door	TE 626 3D A8 ST
	Aluminum frame	Specified by manufacturer
Mounting bracket	TE 626 3D A8 BW/1	

Installation Tools

Jig	Universal milling frame	
Step 1	routing template	No. 5 251062 5
Step 2	routing template	No. 5 251063 5
Step 3	routing template	No. 5 251069 5
Step 3 (without cladding)	routing template	No. 5 251095 5

Application Range

Fire Resistant, Smoke Resistant, Soundproof, Forced Entry Resistant

Note

The load capacity mentioned above refers to the use of 2 hinges per door leaf with a height/width ratio 2:1 (see page 46 for further detail).

For a minimum door panel thickness of 40 mm (1-5/8" plus cladding).

Fire rated doors: Check with door manufacturer regarding the usage of additional required intumescent material.

Cover plates for doors without cladding are available upon request – see page 33.

Square-corner cover plates are available upon request – see page 34.

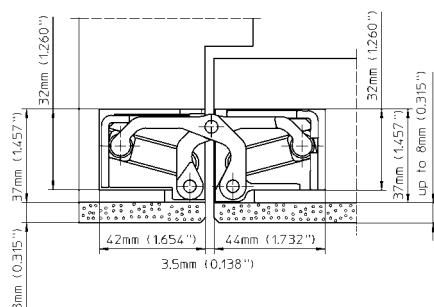
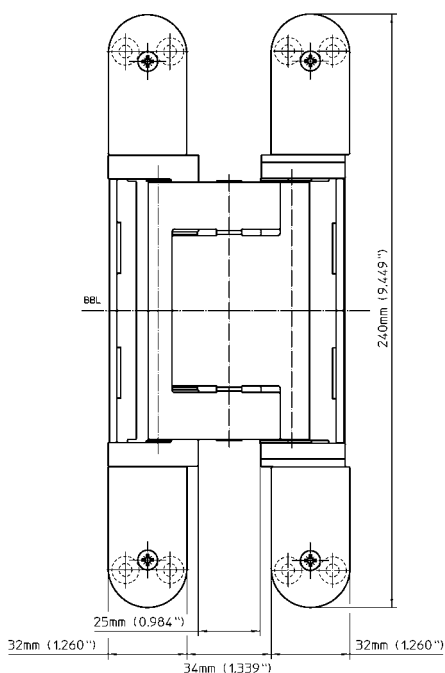

TECTUS

TE 540 3D A8 Energy Kit

With integrated and continuous energy transfer for flush commercial doors with claddings of up to 8 mm (0.315")

Hinge **up to 100 kg (220 lbs.)**

Product Features

- Multiple connection adapter options
- Completely concealed hinge system
- For wood, steel or aluminum door panels and frames
- Easily adjustable in three dimensions (side +/- 3.0 mm (0.118"), height +/- 3.0 mm (0.118"), compression +/- 1.0 mm (0.039"))
- Maintenance-free slide bearings
- UL listed for 20 minute fire door

The specification text can be downloaded from the PRODUCTSELECTOR at www.simonswerk-usa.com.

Technical Data

Load capacity	100 kg (220 lbs.)
Length	200 mm (7.874")
Width (door)	per 32/37 mm (1.260/1.457")
Width (frame)	per 32/37 mm (1.260/1.457")
Router bit / collar Ø	3/4" / 1"
No. of wires/Wire cross section	16/0.14 mm ²
Max. voltage	50 V (for voltages of 24 V or higher only with safeguarded power supply)
Max. current	0.8 A (per wire)

Finishes

satin chrome look (F1) (124), stainless steel look (SSL) (126), other finishes available upon request

Combinations

Receiver/Reinforcement	Commercial frame	Frame mounted
	Casing frame	TE 540 3D FZ
	Steel frame	TE 540 3D A8 SZ
	Steel door	TE 540 3D A8 ST
	Aluminum frame	Specified by manufacturer
Accessories	Round Cable 10m (393.701") Custom Adapter	

Installation Tools (in addition to templates for standard versions)

Routing for raceway	routing template	No. 5 251082 5
---------------------	------------------	----------------

Application Range

Fire Resistant, Smoke Resistant, Soundproof, Forced Entry Resistant

Note

The load capacity mentioned above refers to the use of 2 hinges per door leaf with a height/width ratio of 2:1 (see page 46 for further detail).

For a minimum door panel thickness of 40 mm (1-5/8" plus cladding).

Fire rated doors: Check with door manufacturer regarding the usage of additional required intumescent material.

Cover plates for doors without cladding are available upon request – see page 33.

Square-corner cover plates are available upon request – see page 34.

Kit includes two 3 m (118.110") round cables.

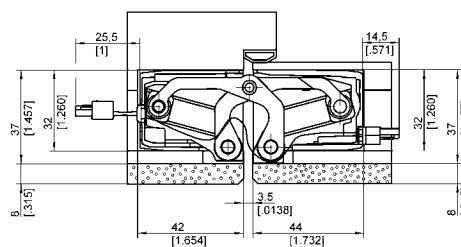
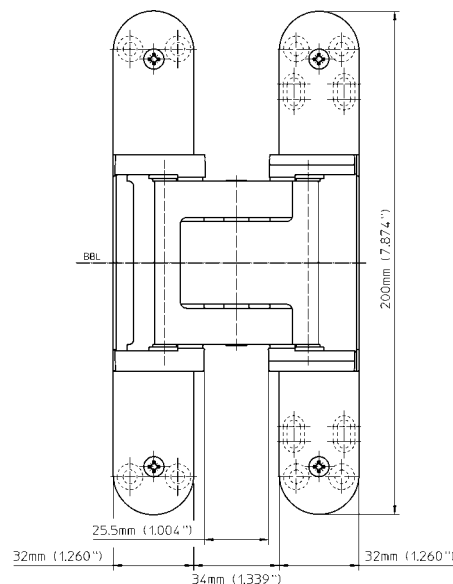
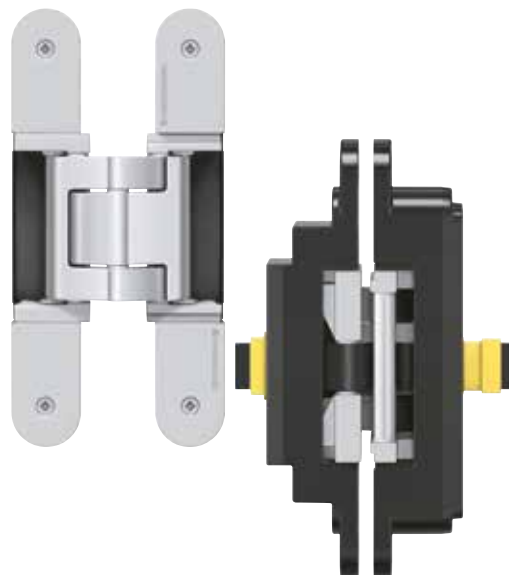

TECTUS

TE 640 3D A8 Energy Kit

With integrated and continuous energy transfer for flush high performance commercial doors with claddings of up to 8 mm (0.315")

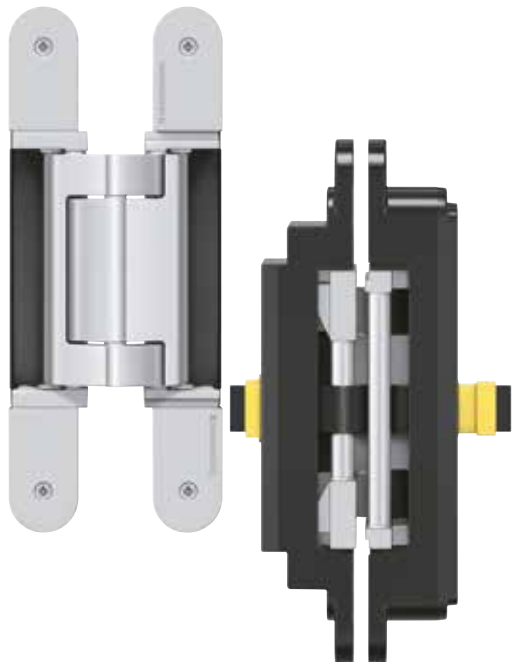

Hinge **up to 160 kg (352 lbs.)**

Product Features

- Multiple connection adapter options
- Completely concealed hinge system
- For wood, steel or aluminum door panels and frames
- Easily adjustable in three dimensions (side +/- 3.0 mm (0.118"), height +/- 3.0 mm (0.118"), compression +/- 1.0 mm (0.039"))
- Maintenance-free slide bearings
- UL listed for 20 minute fire door

The specification text can be downloaded from the PRODUCTSELECTOR at www.simonswerk-usa.com.

Technical Data

Load capacity	160 kg (352 lbs.)
Length	240 mm (9.449")
Width (door)	per 32/37 mm (1.260/1.457")
Width (frame)	per 32/37 mm (1.260/1.457")
Router bit/collar Ø	3/4" / 1"
No. of wires/Wire cross section	16/0.14 mm ²
Max. voltage	50 V (for voltages of 24 V or higher only with safeguarded power supply)
Max. current	0.8 A (per wire)

Finishes

satin chrome look (F1) (124), stainless steel look (SSL) (126), other finishes available upon request

Combinations

Receiver/Reinforcement	Commercial frame	Frame mounted
	Casing frame	TE 640 3D FZ
	Steel frame	TE 640 3D A8 SZ
	Steel door	TE 640 3D A8 ST
	Aluminum frame	Specified by manufacturer
Accessories	Round Cable 10m (393.701") Custom Adapter	

Installation Tools (in addition to templates for standard versions)

Routing for raceway	routing template	No. 5 251082 5
---------------------	------------------	----------------

Application Range

Fire Resistant, Smoke Resistant, Soundproof, Forced Entry Resistant

Note

The load capacity mentioned above refers to the use of 2 hinges per door leaf with a height/width ratio of 2:1 (see page 46 for further detail).

For a minimum door panel thickness of 40 mm (1-5/8" plus cladding).

Fire rated doors: Check with door manufacturer regarding the usage of additional required intumescent material.

Cover plates for doors without cladding are available upon request – see page 33.

Square-corner cover plates are available upon request – see page 34.

Kit includes two 3 m (118.110") round cables.

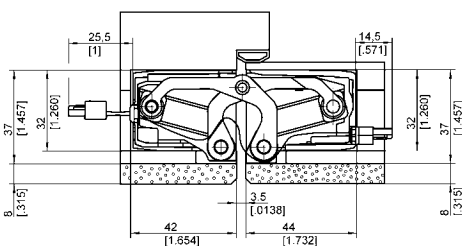
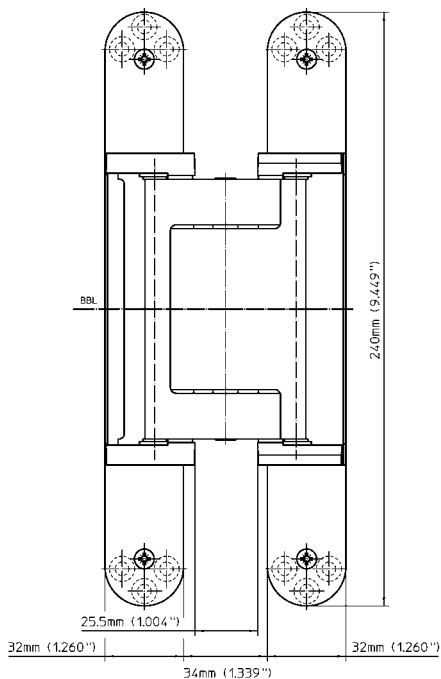

TECTUS

TE 626 3D A8 Energy Kit

Manufactured of solid stainless steel with integrated and continuous energy transfer for flush high performance commercial doors with claddings up to 8 mm (0.315")

Hinge **up to 300 kg (661 lbs.)**

Product Features

- Solid non-magnetic stainless steel (304 series)
- Multiple connection adapter options
- Completely concealed hinge system
- For wood, steel or aluminum door panels and frames
- Easily adjustable in three dimensions (side +/- 3.0 mm (0.118"), height +/- 3.0 mm (0.118"), compression +/- 1.0 mm (0.039"))
- Maintenance-free slide bearings
- UL listed for 180 minute fire door

The specification text can be downloaded from the PRODUCTSELECTOR at www.simonswerk-usa.com.

Technical Data

Load capacity	300 kg (661 lbs.)
Length	240 mm (9.449")
Width (door)	32 mm (1.260")
Width (frame)	32 mm (1.260")
Router bit / collar Ø	3/4" / 1"
No. of wires / Wire cross section	16/0.14 mm ²
Max. voltage	50 V (for voltages of 24 V or higher only with safeguarded power supply)
Max. current	0.8 A (per wire)

Finishes

satin stainless steel (304 series) (040), other finishes available upon request

Combinations

Receiver/Reinforcement	Commercial frame	Frame mounted
	Casing frame	TE 626 3D A8 FZ
	Steel frame	TE 626 3D A8 SZ
	Steel door	TE 626 3D A8 ST
	Aluminum frame	Specified by manufacturer
Accessories		Round Cable 10m (393.701")
		Custom adapter

Installation Tools (in addition to templates for standard versions)

Routing for raceway routing template No. 5 251082 5

Application Range

Fire Resistant, Smoke Resistant, Soundproof, Forced Entry Resistant

Note

The load capacity mentioned above refers to the use of 2 hinges per door leaf with a height/width ratio 2:1 (see page 46 for further detail).

For a minimum door panel thickness of 40 mm (1-5/8" plus cladding).

Fire rated doors: Check with door manufacturer regarding the usage of additional required intumescent material.

Cover plates for doors without cladding are available upon request – see page 33.

Square-corner cover plates are available upon request – see page 34.

Kit includes two 3 m (118.110") round cables.

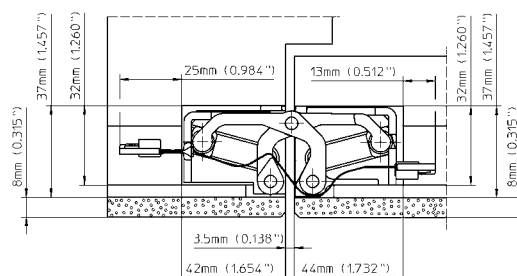
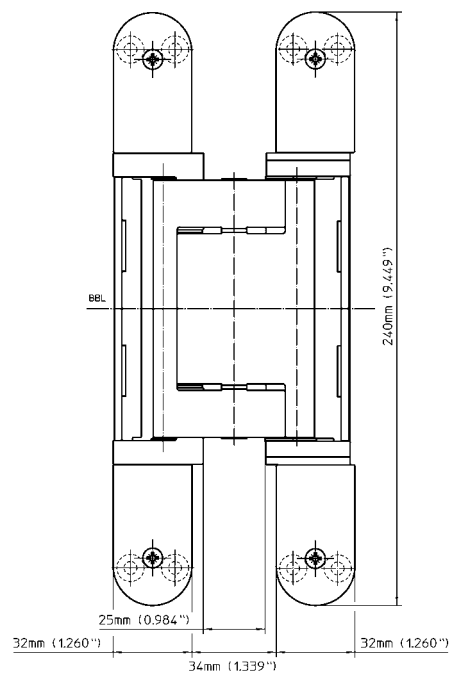

TECTUS

Cover plate set TECTUS A8 radius

Covers door prep for use with wide-throw A8 hinges when installed without cladding



Accessories

Cover plate set

Finishes

satin chrome look (F1) (124), stainless steel look (SSL) (126), other finishes available upon request

Combinations

Hinge	TE 540 3D A8
	TE 640 3D A8
	TE 540 3D A8 Energy Kit
	TE 640 3D A8 Energy Kit

Note

The application of A8 hinges installed without cladding provides greater unobstructed clearance around trim moldings and baseboards.

Please specify the exact hinge model. Set includes 4 plates for both door panel and frame side.

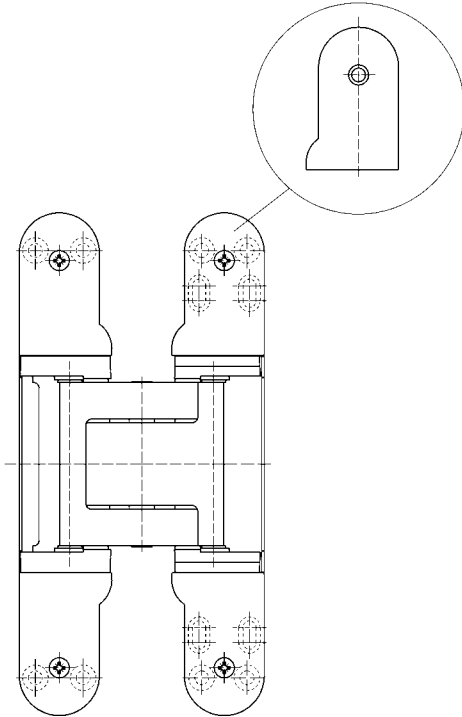

TE 540 3D A8 shown

TECTUS

Square-corner cover plates

Add on part that accommodates corner door and frame preparation

Accessories

Cover plate set

Product Features

- Easy field replacement for the radius corner plate
- Aids in preparation for hollow metal door projects
- Contemporary, high-end hand-crafted appearance

Finishes

Standard Finishes: satin chrome look (F1) (124), satin nickel look (F2) (125), stainless steel look (SSL) (126), rustic umber (156), bronze metallic (168), traffic white (RAL 9016) (070), matte deep black (RAL9005) (107), polished brass (030), polished nickel (038), satin nickel (144), satin chrome (146)

Combinations

Hinge	TE 340 3D
	TE 526 3D
	TE 527 3D
	TE 540 3D
	TE 640 3D
	TE 645 3D
	TE 540 3D A8
	TE 640 3D A8
	TE 626 3D A8
	energy transfer
	TE 526 3D Energy Kit
	TE 527 3D Energy Kit
	TE 540 3D Energy Kit
	TE 640 3D Energy Kit
	TE 645 3D Energy Kit
	TE 540 3D A8 Energy Kit
	TE 640 3D A8 Energy Kit
	TE 626 3D A8 Energy Kit

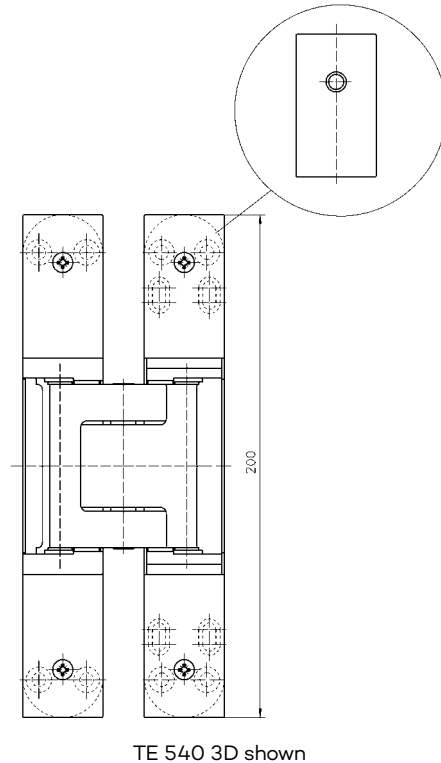

TE 540 3D shown

Note

Please specify the exact hinge model. Set includes 2 plates for either door panel or frame side.

TECTUS

TE 640 3D BW

Mounting brackets for heavy-duty doors with claddings up to either 16 mm (0.630") or 20 mm (0.787") on both sides



Receiver		Commercial frame
-----------------	--	-------------------------

Technical Data

Load capacity	120 kg (264 lbs.)
---------------	-------------------

Finishes

blue galvanized (SW 010)

Combinations

Hinge	TE 640 3D
-------	-----------

Note

The load capacity mentioned above refers to the use of 2 hinges per door leaf with a height / width ratio of 2:1.

The cladding material where the hinge will be installed, must be removed in order for the bracket to be installed. This bracket can be used for doors with standard cladding thickness of either 5/8" or 3/4" on both sides. The mounting brackets are sold individually. Please specify the correct mounting bracket with your order.

Available Options

Claddings up to 16 mm (0.630")	TE 640 3D BW/16
--------------------------------	-----------------

Claddings up to 20 mm (0.787")	TE 640 3D BW/20
--------------------------------	-----------------

Detailed information in our PRODUCTSELECTOR at www.simonswerk-usa.com.

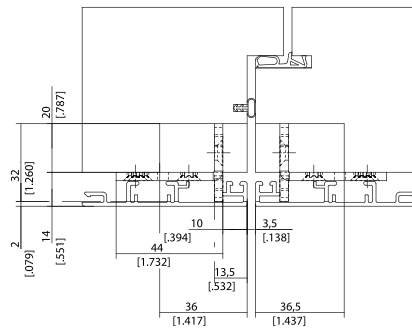
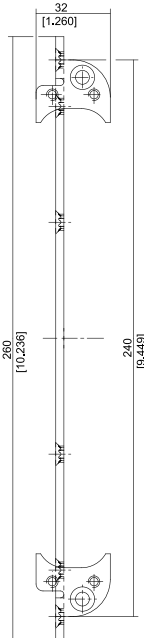

wood / aluminum system

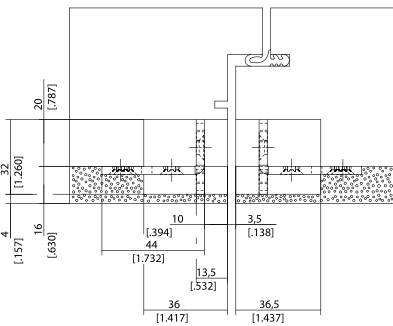

claddings up to 16 mm

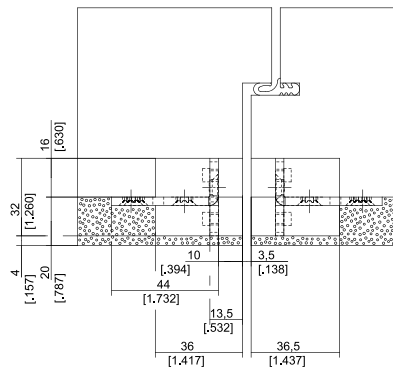

claddings up to 20 mm

TECTUS

Receiver SZ

Reinforcement for steel and stainless steel frames



TE 540 3D SZ

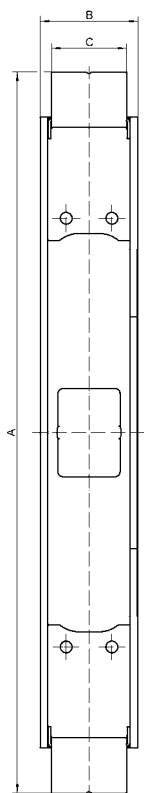

Fixing	Steel frame
--------	-------------

Finishes

galvanized (010), satin stainless steel (040)

Combinations

Hinge	TE 240 3D	
	TE 340 3D	
	TE 526 3D	
	TE 527 3D	
	TE 540 3D	
	TE 541 3D FVZ	
	TE 640 3D	
	TE 645 3D	
	TE 540 3D A8	
	TE 640 3D A8	
	TE 626 3D A8	
	energy transfer	TE 240 3D Energy Kit
		TE 340 3D Energy Kit
		TE 526 3D Energy Kit
TE 527 3D Energy Kit		
TE 540 3D Energy Kit		
TE 640 3D Energy Kit		
TE 645 3D Energy Kit		
TE 540 3D A8 Energy Kit		
TE 640 3D A8 Energy Kit		
TE 626 3D A8 Energy Kit		

Note

Please specify the exact hinge model when ordering.

TE 540 3D receiver shown. Drawings for other receiver sizes available upon request.

Model Variants	A	B	C
TE 240 3D	205.0 mm (8.071")	27.4 mm (1.079")	21.8 mm (0.858")
TE 340 3D	210.0 mm (8.268")	35.0 mm (1.378")	26.0 mm (1.024")
TE 526 3D	210.0 mm (8.268")	35.0 mm (1.378")	26.0 mm (1.024")
TE 527 3D	210.0 mm (8.268")	35.0 mm (1.378")	26.0 mm (1.024")
TE 540 3D	286.0 mm (11.260")	38.5 mm (1.516")	29.6 mm (1.165")
TE 541 3D FVZ	286.0 mm (11.260")	38.5 mm (1.516")	29.6 mm (1.165")
TE 640 3D	286.0 mm (11.260")	38.5 mm (1.516")	29.6 mm (1.165")
TE 645 3D	328.0 mm (12.913")	42.5 mm (1.673")	37.0 mm (1.457")
TE 540 3D A8	286.0 mm (11.260")	38.5 mm (1.516")	29.6 mm (1.165")
TE 640 3D A8	286.0 mm (11.260")	38.5 mm (1.516")	29.6 mm (1.165")
TE 626 3D A8	286.0 mm (11.260")	38.5 mm (1.516")	29.6 mm (1.165")

TECTUS

Receiver ST

Reinforcement for steel and stainless steel door panels

Fixing		Steel door
---------------	--	-------------------

Finishes

galvanized (010), satin stainless steel (040)

Combinations

Hinge	TE 240 3D	
	TE 340 3D	
	TE 526 3D	
	TE 527 3D	
	TE 540 3D	
	TE 541 3D FVZ	
	TE 640 3D	
	TE 645 3D	
	TE 540 3D A8	
	TE 640 3D A8	
	TE 626 3D A8	
	energy transfer	TE 240 3D Energy Kit
		TE 340 3D Energy Kit
TE 526 3D Energy Kit		
TE 527 3D Energy Kit		
TE 540 3D Energy Kit		
TE 640 3D Energy Kit		
TE 645 3D Energy Kit		
TE 540 3D A8 Energy Kit		
TE 640 3D A8 Energy Kit		
TE 626 3D A8 Energy Kit		

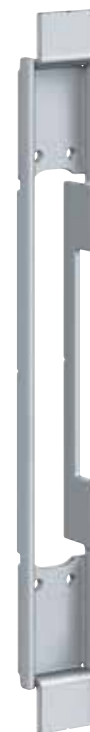

TE 540 3D ST



Note

Please specify the exact hinge model when ordering.

TE 540 3D receiver shown. Drawings for other receiver sizes available upon request.

Includes hinge mounting screws.

Model Variants	A	B	C
TE 240 3D	200.0 mm (7.874")	23.0 mm (0.906")	17.0 mm (0.669")
TE 340 3D	225.0 mm (8.858")	33.3 mm (1.311")	27.3 mm (1.075")
TE 526 3D	205.0 mm (8.071")	32.0 mm (1.260")	26.0 mm (1.024")
TE 527 3D	205.0 mm (8.071")	32.0 mm (1.260")	26.0 mm (1.024")
TE 540 3D	286.0 mm (11.260")	38.5 mm (1.516")	29.6 mm (1.165")
TE 541 3D FVZ	238.0 mm (9.370")	33.3 mm (1.311")	27.3 mm (1.075")
TE 640 3D	300.0 mm (11.811")	38.3 mm (1.508")	31.3 mm (1.232")
TE 645 3D	312.0 mm (12.283")	41.3 mm (1.626")	33.3 mm (1.311")
TE 540 3D A8	253.0 mm (9.961")	37.3 mm (1.469")	31.2 mm (1.232")
TE 640 3D A8	300.0 mm (11.811")	38.3 mm (1.508")	31.3 mm (1.232")
TE 626 3D A8	300.0 mm (11.811")	38.3 mm (1.508")	31.3 mm (1.232")

TECTUS

Receiver TECTUS for steel frames
and steel doors

TE 240 3D

Receiver/Reinforcement steel frame: TE 240 3D SZ

Receiver/Reinforcement steel door: TE 240 3D ST

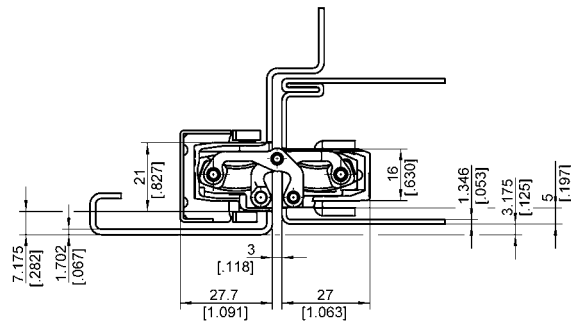

TE 340 3D

Receiver/Reinforcement steel frame: TE 340 3D SZ

Receiver/Reinforcement steel door: TE 340 3D ST

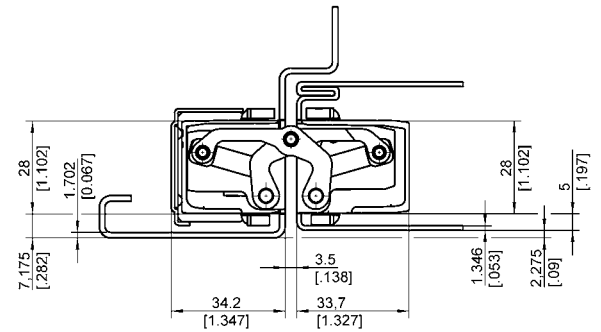

TE 526 3D

Receiver/Reinforcement steel frame: TE 526 3D SZ

Receiver/Reinforcement steel door: TE 526 3D ST

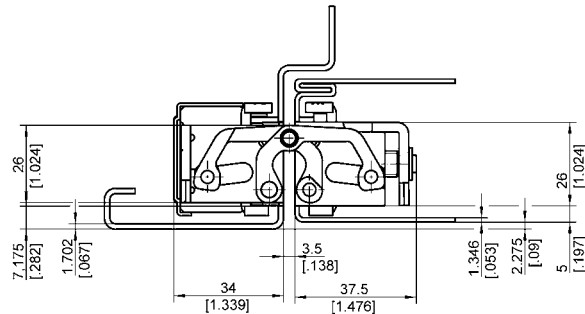

TE 527 3D

Receiver/Reinforcement steel frame: TE 527 3D SZ

Receiver/Reinforcement steel door: TE 527 3D ST

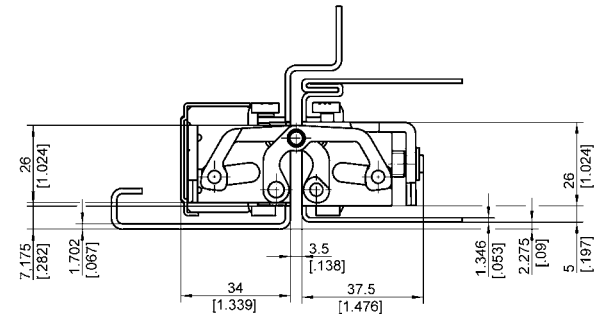

TE 541 3D FVZ

Receiver/Reinforcement steel frame: TE 541 3D FVZ SZ

Receiver/Reinforcement steel door: TE 541 3D FVZ ST

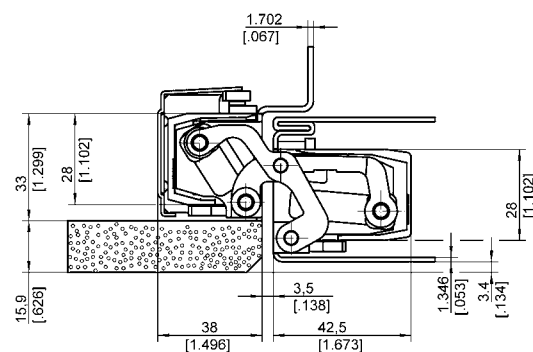

TECTUS

Receiver TECTUS for steel frames and steel doors

TE 540 3D

Receiver/Reinforcement steel frame: TE 540 3D SZ

Receiver/Reinforcement steel door: TE 540 3D ST

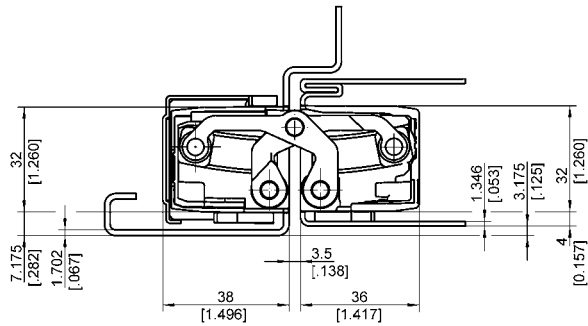

TE 640 3D

Receiver/Reinforcement steel frame: TE 640 3D SZ

Receiver/Reinforcement steel door: TE 640 3D ST

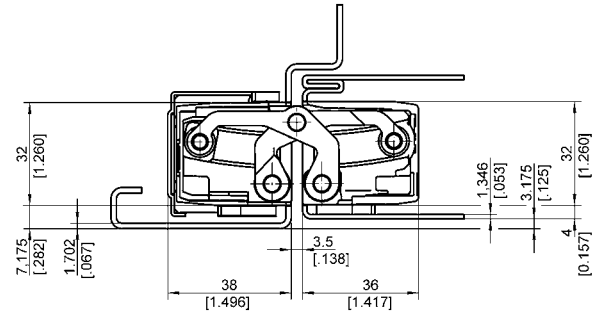

TE 540 3D A8

Receiver/Reinforcement steel frame: TE 540 3D A8 SZ

Receiver/Reinforcement steel door: TE 540 3D A8 ST

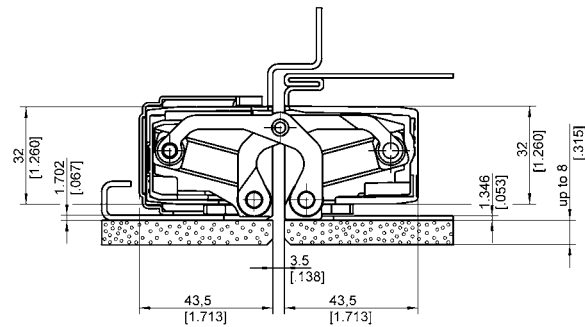

TE 640 3D A8

Receiver/Reinforcement steel frame: TE 640 3D A8 SZ

Receiver/Reinforcement steel door: TE 640 3D A8 ST

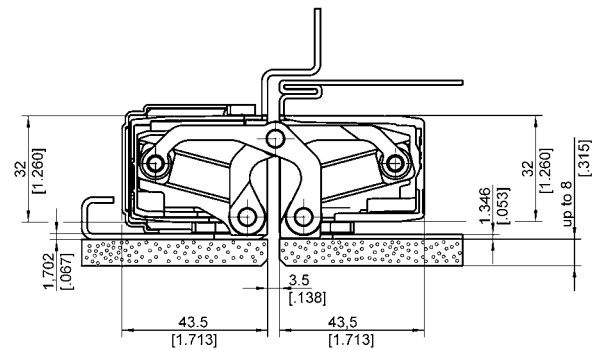

TE 626 3D A8

Receiver/Reinforcement steel frame: TE 626 3D A8 SZ

Receiver/Reinforcement steel door: TE 626 3D A8 ST

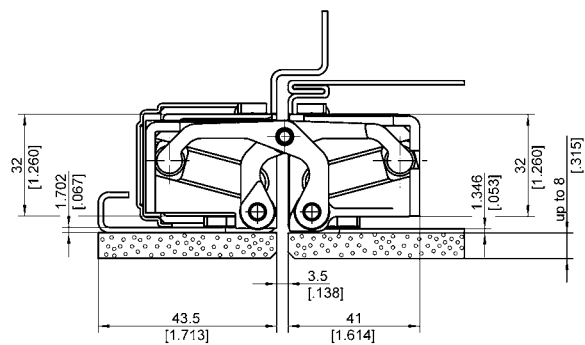

TECTUS

Fixing Plate TECTUS Series

For reinforcement of casing frames

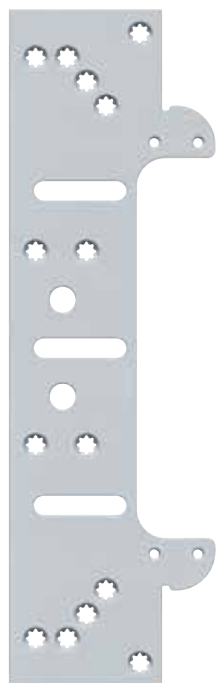

TE 540 3D FZ

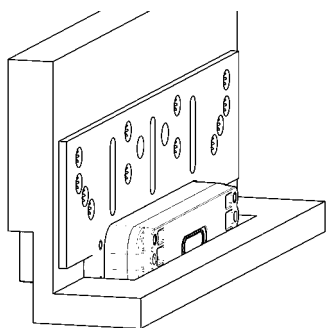
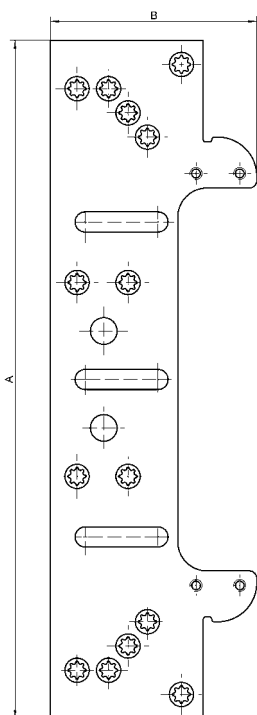

Fixing	Casing frame
Finishes	
galvanized (010)	
Combinations	
Hinge	TE 240 3D TE 340 3D TE 526 3D TE 527 3D TE 540 3D TE 541 3D FVZ TE 640 3D TE 540 3D A8 TE 640 3D A8 TE 626 3D A8
energy transfer	TE 240 3D Energy Kit TE 340 3D Energy Kit TE 526 3D Energy Kit TE 527 3D Energy Kit TE 540 3D Energy Kit TE 640 3D Energy Kit TE 645 3D Energy Kit TE 540 3D A8 Energy Kit TE 640 3D A8 Energy Kit TE 626 3D A8 Energy Kit

Note

Shims for casing strengths 22-28 mm (0.866-1.102") are included.

Please specify the exact hinge in your order.

TE 540 3D fixing plate shown. Drawings for other fixing plate sizes available upon request.

Model Variants

	A	B
TE 240 3D	160.0 mm (6.299")	70.0 mm (2.756")
TE 340 3D	200.0 mm (7.874")	85.5 mm (3.366")
TE 526 3D	180.0 mm (7.087")	80.0 mm (3.150")
TE 527 3D	180.0 mm (7.087")	80.0 mm (3.150")
TE 540 3D	280.0 mm (11.024")	85.0 mm (3.346")
TE 541 3D FVZ	280.0 mm (11.024")	85.0 mm (3.346")
TE 640 3D	280.0 mm (11.024")	85.0 mm (3.346")
TE 540 3D A8	280.0 mm (11.024")	85.0 mm (3.346")
TE 640 3D A8	280.0 mm (11.024")	85.0 mm (3.346")
TE 626 3D A8	280.0 mm (11.024")	85.0 mm (3.346")

TECTUS

Fixing Plate TECTUS Series

TE 240 3D

Fixing plate: TE 240 3D FZ/1

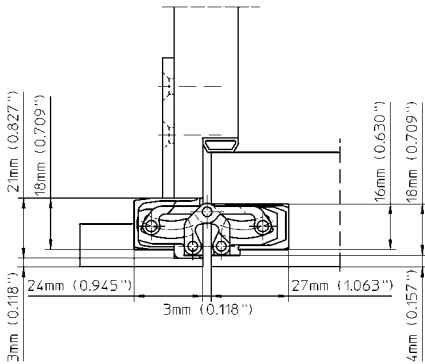

TE 340 3D

Fixing plate: TE 340 3D FZ

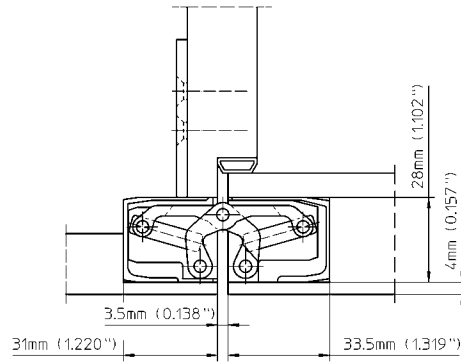

TE 526 3D

Fixing plate: TE 526/527 3D FZ/1

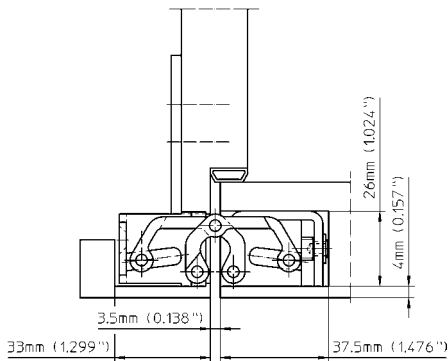

TE 527 3D

Fixing plate: TE 526/527 3D FZ/1

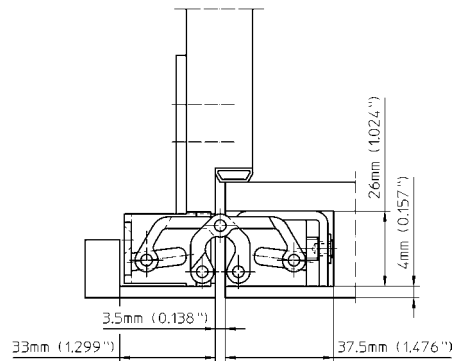

TE 541 3D FVZ

Fixing plate: TE 541 3D FVZ FZ/1

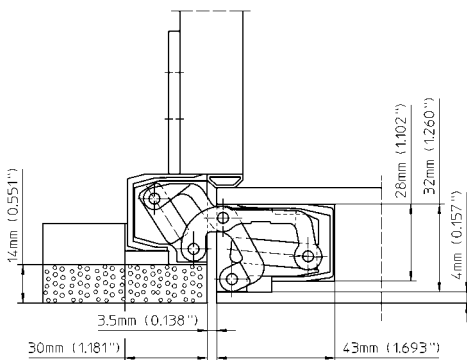

TECTUS

Fixing Plate TECTUS for casing frames

TE 540 3D

Fixing plate: TE 540 3D FZ

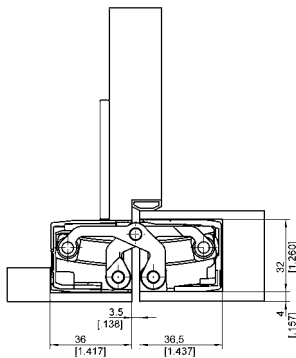

TE 640 3D

Fixing plate: TE 640 3D FZ

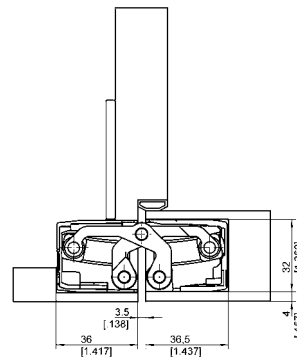

TE 540 3D A8

Fixing plate: TE 540 3D FZ

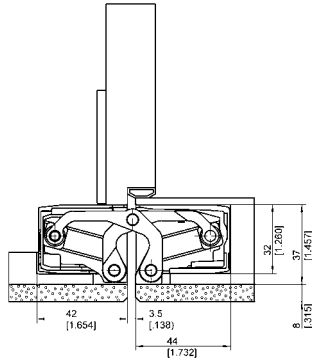

TE 640 3D A8

Fixing plate: TE 640 3D FZ

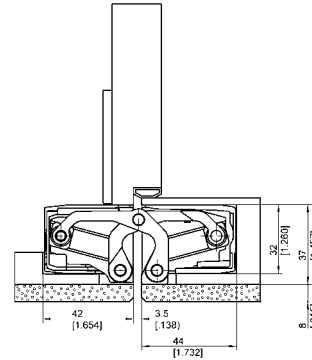

TE 626 3D A8

Fixing plate: TE 626 3D A8 FZ

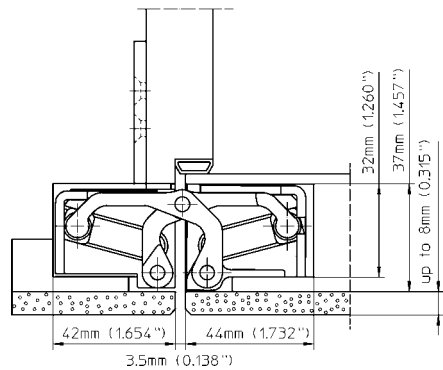

TECTUS

Preparation and Installation

Frame and door prep

Perform routing according to SIMONSWERK routing data. Use router bit with a \varnothing of 24 mm (3/4") (TE 240 3D router bit \varnothing 16 mm (1/2")) and collar ring \varnothing 30 mm (1"). routing templates for metric router bits and collars available upon request.

Installation of hinge to door panel

Affix door part with enclosed wood screws.

Installation of hinge to frame

Commercial frame

Affix frame part with enclosed wood screws.

Casing frame

Additional fixing plate for reinforcement is required. Affix the fixing plate with the appropriate screws (not included) behind the casing frame. Affix the hinge by using the enclosed M5 screws.

To ensure flush hinge installation, shims are provided with the fixing plate.

Steel frame

Affix frame part of the hinge with the prepared receiver inside the door frame by using the enclosed M5 screws. To ensure flush hinge installation, shims are provided with the fixing plate.

Fix cover plates with the enclosed screws.

Application technology

Use the Universal Milling Frame (jig) No. 118 along with the required routing templates.

Special Milling Frame (long) required for TE 645 3D.

Drill jig for TE 526 3D and TE 527 3D available upon request.

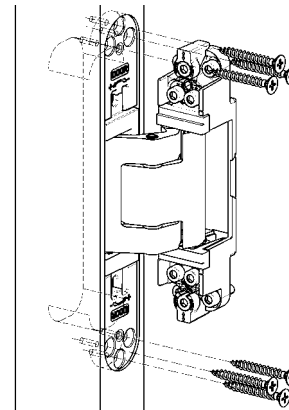

TE 540 3D

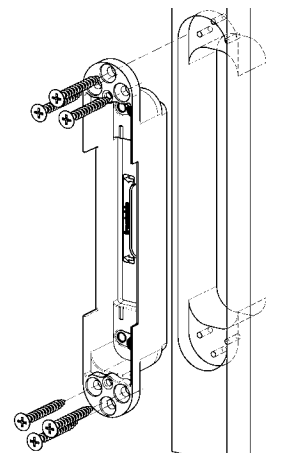

TE 540 3D

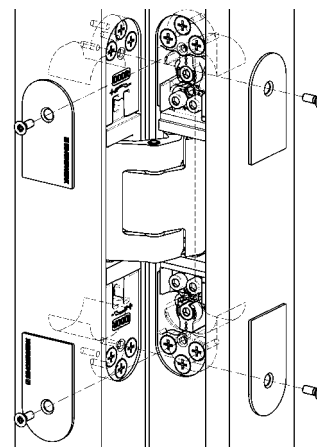

TE 540 3D

TECTUS

Additional Installation for TECTUS Energy

Frame and door prep for raceway routing

1

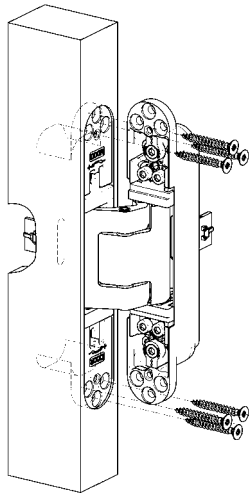

2

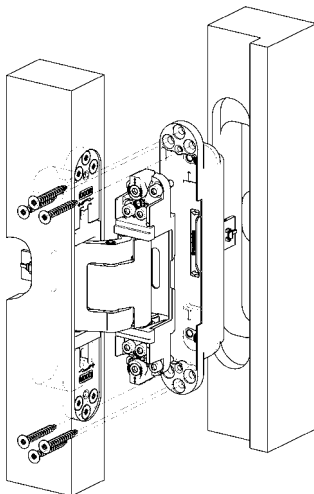

4

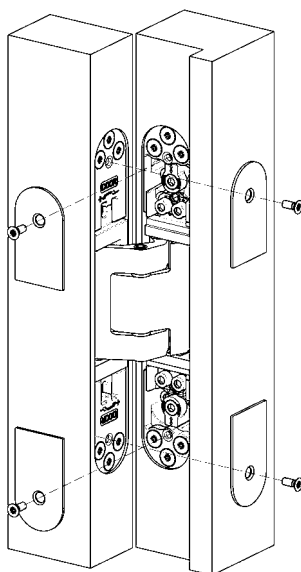

- 1 Perform additional routing for the cable on door panel and frame. Plug the connectors together and install the sash part.
- 2 Plug the connectors of the hinge frame part and install the hinge in the jamb.
- 3 Make sure the plug connectors are engaged properly.
- 4 Screw the cover plates on by using the enclosed tapping screws onto frame and door part.

3

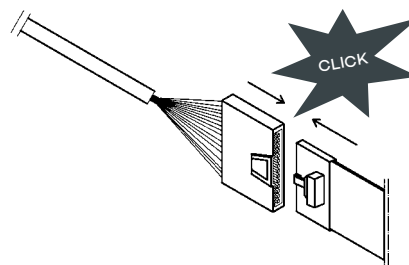

TECTUS

Adjustment TECTUS Series

Three way adjustable

Side	+/- 3 mm (0.118")
Height	+/- 3 mm (0.118")
Depth	+/- 1 mm (0.039")

Side adjustment (horizontal)

- Adjust the adjusting spindles using a 4 mm (0.157") Allen wrench
- Turn side adjustment screw counterclockwise for increasing the air gap max. 3 mm (0.118") on the locking side
- Turn side adjustment screw clockwise for decreasing the air gap max. 3 mm (0.118") on the locking side

Height adjustment (vertical)

- Slightly loosen all four clamping screws on all hinges
 - Adjust the vertical position of the door
 - Turn the lower height adjustment screw clockwise for raising the door
 - Turn the lower height adjustment screw counterclockwise for lowering the door
- Note: Before raising the door make sure that the upper adjustment screw is loosened.
- Retighten the clamping screws on all hinges

Depth adjustment (in/out)

- Slightly loosen the fixing screws
- Align the door to the desired compression
- Retighten the clamping screws

All adjustments can be performed with a 4 mm (0.157") Allen wrench.

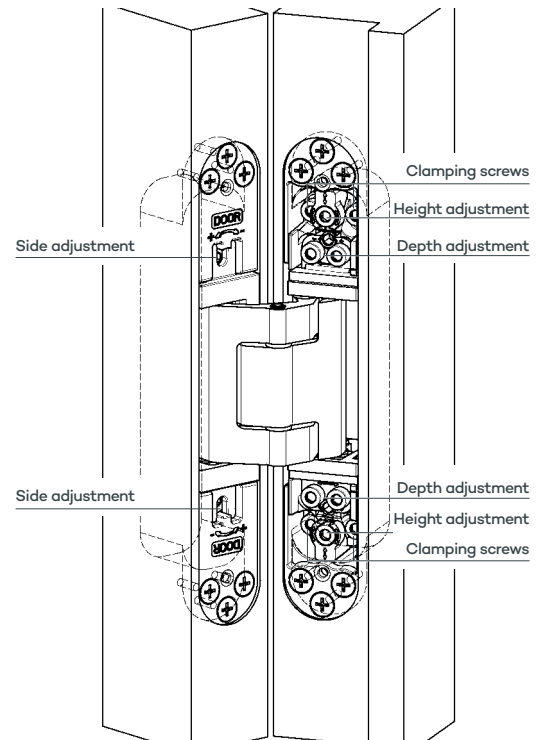

TECTUS

Adjustment TECTUS TE 526/527 3D

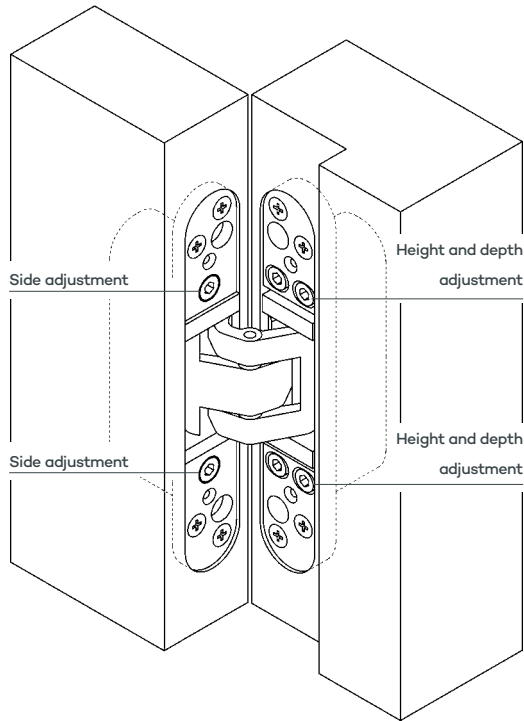

Three way adjustable

Side	+/- 3 mm (0.118")
Height	+/- 3 mm (0.118")
Depth	+/- 1 mm (0.039")

Side adjustment (horizontal)

- Adjust the adjusting spindles using a 4 mm (0.157") Allen wrench
- Turn side adjustment screw counterclockwise for increasing the air gap max. 3 mm (0.118") on the locking side
- Turn side adjustment screw clockwise for decreasing the air gap max. 3 mm (0.118") on the locking side

Height (vertical) and depth (in/out) adjustment

- Wedge the door
- Slightly loosen all four clamping screws on all hinges
- Adjust the height and depth position of the door manually
- Retighten the clamping screws

All adjustments can be performed with a 4 mm (0.157") Allen wrench.

Hinge Positions

TECTUS Series

To increase the load capacity of the hinges, a third hinge needs to be positioned 350 mm / 14" below the upper hinge (center to center). The use of a third hinge in order to increase the load capacity has to be determined on a case by case basis. Our hinge data refers to a height/width ratio of the door of 2:1 or more. Please contact us for further information and also see the door manufacturers instructions.

Proper preparation and alignment as well as tension-free adjustment are crucial for a hassle-free operation.

Application with increased load capacity

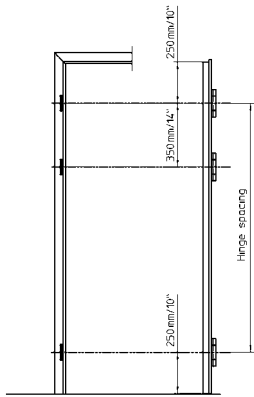

Examples for applications with different door heights

< 8 ft

≥ 8 ft

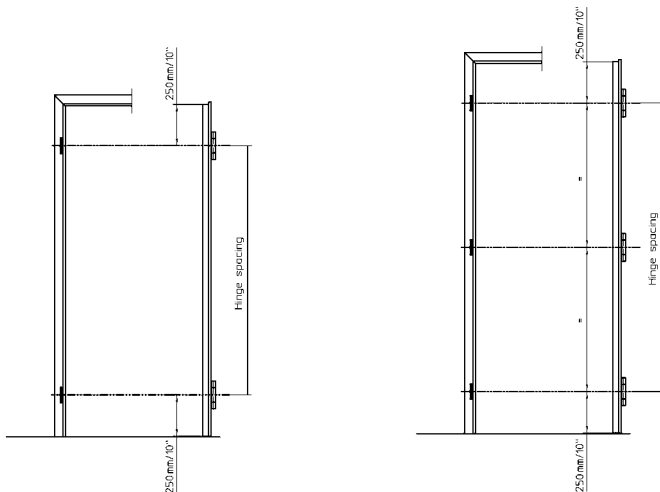

The hinge spacing does not increase the load capacity.

Note: We recommend for all exterior doors the use of three hinges.

Load Capacities

Overview of load values for hinges

The following table provides an overview of the maximum load value for the individual hinge type, taking the interaction of width and height of the door as well as the hinge spacing into account.

The reference load carrying capacity is based on a height/width ratio of 2:1. For example, assuming a reference value with door leaf dimensions of 2000 x 1000 mm (78.8" x 39.4") (H x W), a positioning of 250 mm / 10" from the top and 250 mm / 10" from the bottom to the center of each hinge is required (see page 46).

For required number of hinges and hinge spacing refer to door manufacturer recommendation.

Values represent hinges positioned 250 mm / 10" from the top and 250 mm / 10" from the bottom to center of each hinge (see page 46).

Green: load value = reference value, **Orange:** load value < reference value.

Reference value **60 kg / 132 lbs.**

TE 240 3D TE 240 3D Energy Kit

• Door panel height in mm / inch	>2743/108	60/132	60/132	60/132	60/132	60/132	60/132	60/132	60/132	60/132	60/132	60/132	
	2591/102	60/132	60/132	60/132	60/132	60/132	60/132	60/132	60/132	60/132	60/132	60/132	
	2438/96	60/132	60/132	60/132	60/132	60/132	60/132	60/132	60/132	60/132	60/132	58/127	
	2388/94	60/132	60/132	60/132	60/132	60/132	60/132	60/132	60/132	60/132	60/132	57/125	
	2337/92	60/132	60/132	60/132	60/132	60/132	60/132	60/132	60/132	60/132	57/125	55/121	
	2286/90	60/132	60/132	60/132	60/132	60/132	60/132	60/132	60/132	58/127	56/123	54/119	54/119
	2235/88	60/132	60/132	60/132	60/132	60/132	60/132	59/130	56/123	54/119	54/119	52/114	52/114
	2184/86	60/132	60/132	60/132	60/132	60/132	60/132	57/125	55/121	52/114	52/114	50/110	50/110
	2134/84	60/132	60/132	60/132	60/132	58/127	55/121	53/116	51/112	51/112	49/108	49/108	47/103
	2083/82	60/132	60/132	60/132	58/127	56/123	54/119	51/112	49/108	49/108	47/103	47/103	46/101
	2032/80	60/132	60/132	60/132	57/125	54/119	52/114	50/110	48/105	48/105	46/101	46/101	44/97
	1981/78	60/132	60/132	58/127	55/121	52/114	50/110	48/105	46/101	46/101	44/97	44/97	44/97
		≤ 914/36	965/38	1016/40	1067/42	1118/44	1158/46	1219/48	1270/50	1270/50	1321/52	1321/52	1321/52
	• Door width in mm / inch												

Reference value **80 kg / 176 lbs.**

TE 340 3D TE 340 3D Energy Kit

• Door panel height in mm / inch	>2743/108	80/176	80/176	80/176	80/176	80/176	80/176	80/176	80/176	80/176	80/176	80/176
	2591/102	80/176	80/176	80/176	80/176	80/176	80/176	80/176	80/176	80/176	80/176	80/176
	2438/96	80/176	80/176	80/176	80/176	80/176	80/176	80/176	80/176	80/176	80/176	78/171
	2388/94	80/176	80/176	80/176	80/176	80/176	80/176	80/176	80/176	79/174	76/167	76/167
	2337/92	80/176	80/176	80/176	80/176	80/176	80/176	80/176	80/176	76/167	74/163	74/163
	2286/90	80/176	80/176	80/176	80/176	80/176	80/176	80/176	77/169	74/163	71/156	71/156
	2235/88	80/176	80/176	80/176	80/176	80/176	80/176	78/171	75/165	72/158	69/152	69/152
	2184/86	80/176	80/176	80/176	80/176	80/176	80/176	76/167	73/160	70/154	67/147	67/147
	2134/84	80/176	80/176	80/176	80/176	80/176	77/169	74/163	71/156	68/149	65/143	65/143
	2083/82	80/176	80/176	80/176	77/169	75/165	72/158	69/152	66/145	63/137	63/137	63/137
	2032/80	80/176	80/176	80/176	75/165	72/158	69/152	66/145	64/141	64/141	61/134	61/134
	1981/78	80/176	80/176	77/169	73/160	70/154	67/147	64/141	62/136	62/136	59/130	59/130
		≤ 914/36	965/38	1016/40	1067/42	1118/44	1158/46	1219/48	1270/50	1270/50	1321/52	1321/52
	• Door width in mm / inch											

The specifications above are guidelines. Especially in the case of borderline load requirements, please contact us.

Values represent hinges positioned 250 mm / 10" from the top and 250 mm / 10" from the bottom to center of each hinge (see page 46).

Load Capacities

Overview of load values for hinges

• Door panel height in mm / inch	>2743/108	100/220	100/220	100/220	100/220	100/220	100/220	100/220	100/220	100/220
	2591/102	100/220	100/220	100/220	100/220	100/220	100/220	100/220	100/220	100/220
	2438/96	100/220	100/220	100/220	100/220	100/220	100/220	100/220	100/220	97/213
	2388/94	100/220	100/220	100/220	100/220	100/220	100/220	100/220	99/218	95/209
	2337/92	100/220	100/220	100/220	100/220	100/220	100/220	99/218	96/211	92/202
	2286/90	100/220	100/220	100/220	100/220	100/220	100/220	97/213	93/205	90/198
	2235/88	100/220	100/220	100/220	100/220	100/220	99/218	94/207	91/200	87/191
	2184/86	100/220	100/220	100/220	100/220	100/220	96/211	92/202	88/194	84/185
	2134/84	100/220	100/220	100/220	100/220	97/213	93/205	89/196	85/187	82/180
	2083/82	100/220	100/220	100/220	98/216	94/207	90/198	86/189	83/182	79/174
	2032/80	100/220	100/220	100/220	94/207	91/200	87/191	83/182	80/176	77/169
1981/78	100/220	100/220	96/211	91/200	88/194	84/185	82/180	77/169	74/163	
	≤ 914/36	965/38	1016/40	1067/42	1118/44	1158/46	1219/48	1270/50	1321/52	

• Door width in mm / inch

Reference value **100 kg** / 220 lbs.

TE 541 3D FVZ
TE 540 3D A8
TE 540 3D A8 Energy Kit

• Door panel height in mm / inch	>2743/108	120/264	120/264	120/264	120/264	120/264	120/264	120/264	120/264	120/264
	2591/102	120/264	120/264	120/264	120/264	120/264	120/264	120/264	120/264	120/264
	2438/96	120/264	120/264	120/264	120/264	120/264	120/264	120/264	120/264	117/257
	2388/94	120/264	120/264	120/264	120/264	120/264	120/264	120/264	118/260	114/251
	2337/92	120/264	120/264	120/264	120/264	120/264	120/264	120/264	115/253	111/244
	2286/90	120/264	120/264	120/264	120/264	120/264	120/264	117/257	112/246	108/238
	2235/88	120/264	120/264	120/264	120/264	120/264	118/260	113/249	109/240	104/229
	2184/86	120/264	120/264	120/264	120/264	120/264	115/253	110/242	105/231	101/222
	2134/84	120/264	120/264	120/264	120/264	116/255	111/244	107/235	102/224	98/216
	2083/82	120/264	120/264	120/264	118/260	113/249	108/238	103/227	99/218	95/209
	2032/80	120/264	120/264	120/264	114/251	109/240	104/229	100/220	96/211	92/202
1981/78	120/264	120/264	116/255	110/242	105/231	101/222	97/213	93/205	89/196	
	≤ 914/36	965/38	1016/40	1067/42	1118/44	1158/46	1219/48	1270/50	1321/52	

• Door width in mm / inch

Reference value **120 kg** / 264 lbs.

TE 526 3D
TE 527 3D
TE 540 3D
TE 526 3D Energy Kit
TE 527 3D Energy Kit
TE 540 3D Energy Kit

• Door panel height in mm / inch	>2743/108	160/352	160/352	160/352	160/352	160/352	160/352	160/352	160/352	160/352
	2591/102	160/352	160/352	160/352	160/352	160/352	160/352	160/352	160/352	160/352
	2438/96	160/352	160/352	160/352	160/352	160/352	160/352	160/352	160/352	156/343
	2388/94	160/352	160/352	160/352	160/352	160/352	160/352	160/352	158/348	152/335
	2337/92	160/352	160/352	160/352	160/352	160/352	160/352	160/352	154/339	148/326
	2286/90	160/352	160/352	160/352	160/352	160/352	160/352	155/341	149/328	144/317
	2235/88	160/352	160/352	160/352	160/352	160/352	160/352	158/348	151/332	145/319
	2184/86	160/352	160/352	160/352	160/352	160/352	160/352	153/337	147/324	141/310
	2134/84	160/352	160/352	160/352	160/352	155/341	149/328	142/313	137/302	131/288
	2083/82	160/352	160/352	160/352	156/343	150/330	144/317	138/304	132/291	127/278
	2032/80	160/352	160/352	160/352	153/337	146/321	139/306	134/295	128/282	123/271
1981/78	160/352	160/352	158/348	148/326	141/310	135/297	129/284	124/273	119/262	
	≤ 914/36	965/38	1016/40	1067/42	1118/44	1158/46	1219/48	1270/50	1321/52	

• Door width in mm / inch

Reference value **160 kg** / 352 lbs.

TE 640 3D A8
TE 640 3D A8 Energy Kit

The specifications above are guidelines. Especially in the case of borderline load requirements, please contact us.

Values represent hinges positioned 250 mm / 10" from the top and 250 mm / 10" from the bottom to center of each hinge (see page 46).

Load Capacities

Overview of load values for hinges

Reference value 200 kg / 440 lbs.

TE 640 3D TE 640 3D Energy Kit

• Door panel height in mm / inch	>2743 / 108	200 / 440	200 / 440	200 / 440	200 / 440	200 / 440	200 / 440	200 / 440	200 / 440	200 / 440	200 / 440
	2591 / 102	200 / 440	200 / 440	200 / 440	200 / 440	200 / 440	200 / 440	200 / 440	200 / 440	200 / 440	200 / 440
	2438 / 96	200 / 440	200 / 440	200 / 440	200 / 440	200 / 440	200 / 440	200 / 440	200 / 440	200 / 440	195 / 429
	2388 / 94	200 / 440	200 / 440	200 / 440	200 / 440	200 / 440	200 / 440	200 / 440	200 / 440	198 / 436	190 / 418
	2337 / 92	200 / 440	200 / 440	200 / 440	200 / 440	200 / 440	200 / 440	200 / 440	200 / 440	192 / 423	185 / 407
	2286 / 90	200 / 440	200 / 440	200 / 440	200 / 440	200 / 440	200 / 440	200 / 440	195 / 429	187 / 412	180 / 396
	2235 / 88	200 / 440	200 / 440	200 / 440	200 / 440	200 / 440	200 / 440	198 / 436	189 / 416	182 / 401	175 / 385
	2184 / 86	200 / 440	200 / 440	200 / 440	200 / 440	200 / 440	200 / 440	192 / 423	184 / 405	176 / 388	169 / 372
	2134 / 84	200 / 440	200 / 440	200 / 440	200 / 440	200 / 440	194 / 427	186 / 410	178 / 392	171 / 376	164 / 361
	2083 / 82	200 / 440	200 / 440	200 / 440	200 / 440	197 / 434	188 / 414	180 / 396	173 / 381	166 / 365	159 / 350
	2032 / 80	200 / 440	200 / 440	200 / 440	200 / 440	191 / 421	182 / 401	174 / 383	167 / 368	160 / 352	154 / 339
	1981 / 78	200 / 440	200 / 440	200 / 440	194 / 427	185 / 407	176 / 388	169 / 372	162 / 357	155 / 341	149 / 328
		≤ 914 / 36	965 / 38	1016 / 40	1067 / 42	1118 / 44	1158 / 46	1219 / 48	1270 / 50	1321 / 52	

• Door width in mm / inch

Reference value 300 kg / 661 lbs.

TE 645 3D TE 626 3D A8 TE 645 3D Energy Kit TE 626 3D A8 Energy Kit

• Door panel height in mm / inch	>2743 / 108	300 / 661	300 / 661	300 / 661	300 / 661	300 / 661	300 / 661	300 / 661	300 / 661	300 / 661	300 / 661
	2591 / 102	300 / 661	300 / 661	300 / 661	300 / 661	300 / 661	300 / 661	300 / 661	300 / 661	300 / 661	300 / 661
	2438 / 96	300 / 661	300 / 661	300 / 661	300 / 661	300 / 661	300 / 661	300 / 661	300 / 661	300 / 661	293 / 645
	2388 / 94	300 / 661	300 / 661	300 / 661	300 / 661	300 / 661	300 / 661	300 / 661	300 / 661	297 / 654	285 / 628
	2337 / 92	300 / 661	300 / 661	300 / 661	300 / 661	300 / 661	300 / 661	300 / 661	300 / 661	289 / 637	278 / 612
	2286 / 90	300 / 661	300 / 661	300 / 661	300 / 661	300 / 661	300 / 661	300 / 661	293 / 645	281 / 619	270 / 595
	2235 / 88	300 / 661	300 / 661	300 / 661	300 / 661	300 / 661	300 / 661	296 / 652	284 / 626	274 / 604	262 / 577
	2184 / 86	300 / 661	300 / 661	300 / 661	300 / 661	300 / 661	300 / 661	288 / 634	276 / 608	265 / 584	254 / 559
	2134 / 84	300 / 661	300 / 661	300 / 661	300 / 661	300 / 661	292 / 643	279 / 615	268 / 590	257 / 566	247 / 544
	2083 / 82	300 / 661	300 / 661	300 / 661	300 / 661	296 / 652	283 / 623	271 / 597	259 / 570	249 / 548	239 / 526
	2032 / 80	300 / 661	300 / 661	300 / 661	300 / 661	287 / 632	274 / 604	262 / 577	251 / 553	241 / 531	231 / 509
	1981 / 78	300 / 661	300 / 661	300 / 661	291 / 641	279 / 615	264 / 582	253 / 557	242 / 533	233 / 513	224 / 493
		≤ 914 / 36	965 / 38	1016 / 40	1067 / 42	1118 / 44	1158 / 46	1219 / 48	1270 / 50	1321 / 52	

• Door width in mm / inch

The specifications above are guidelines. Especially in the case of borderline load requirements, please contact us.

Values represent hinges positioned 250 mm / 10" from the top and 250 mm / 10" from the bottom to center of each hinge (see page 46).

TECTUS – Finishes

Powder Coated Finishes*



070 traffic white (RAL 9016)



107 matte deep black (RAL 9005)



124 satin chrome look (F1)



125 satin nickel look (F2)



156 rustic umber



168 bronze metallic

Galvanic Plated Finishes*



030 polished brass



038 polished nickel



144 satin nickel



146 satin chrome



174 bronze finish



175 light bronze finish



176 dark bronze finish



047 satin brass

Brushed Stainless Steel*



040 satin stainless steel



126 stainless steel look (SSL)

* The colors of the finishes shown may differ from the original.

Service – comprehensive expertise for your daily work

We are happy to provide you with all the documentation you need to determine the most suitable hinge system for your building project. We would be delighted to work with you to choose the best solution – from high-quality standard elements right up to the most complex solutions. Please do not hesitate to contact us.

All our brochures and data sheets can be requested in a printed version, or you can simply download them on the spot on our website.

Our friendly and knowledgeable application engineers will be pleased to help you and advise you.

www.simonswerk-usa.com

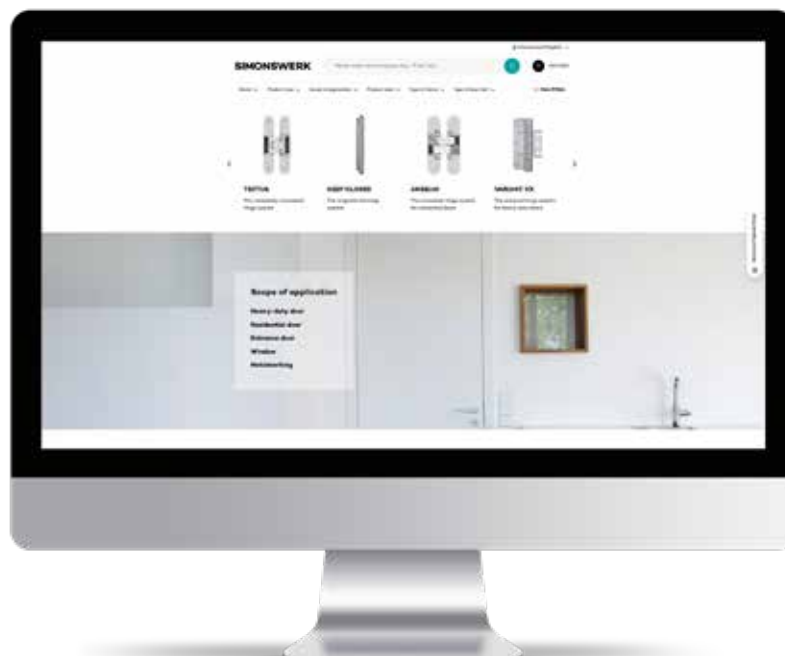

SIMONSWERK GROUP – excellence in product and service

As an internationally operating group of companies, the SIMONSWERK GROUP is the market leader in the area of high-quality hinge systems. With over 900 employees worldwide, we stand for the highest quality standards, constant willingness to innovate and long-lasting customer relationships.

The SIMONSWERK brand combines the entire expertise in hinge systems and unites technical know-how with design standards at the highest level. In addition to innovative product solutions, we offer our customers the best service exactly where it is needed. From personal customer consultations and competent training courses to customised delivery and logistics processes or digital service tools.

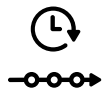

Over 130 years of experience

The perfect foundation for continuous growth with experience



Internationally successful

As the market leader, we are constantly expanding our know-how



Over 900 employees worldwide

Every single employee shapes the vision of the SIMONSWERK GROUP



Focused product solutions

With premium hinge systems for heavy-duty, residential and entrance doors, we offer product solutions for all applications and materials

For our customers and partners

As SIMONSWERK GROUP, we offer hinge systems for commercial, institutional, and residential door applications. The versatility of our designs allows for the product lines to be used on a wide range of applications and materials such as wood, glass, steel, vinyl, and aluminum doors. We provide all interested parties with the best possible support based on their requirements.



SIMONSWERK

TECTUS

The adjustable concealed door hinge

SIMONSWERK North America, Inc.

1171 Universal Boulevard
Whitewater, WI 53190
U.S.A.

B ——— **W**

available in North America through Bridgeport Worldwide
T : +1-800-362-1484 — info@BridgeportWorldwide.com

Member of the

**SIMONSWERK
GROUP**

LIT-SMSWK-020 BW26-017 02.2025

© SIMONSWERK GmbH
07/2024, 1.5, North America (en)
Subject to technical modifications.