



QUICK SPECS

Scan code for full specifications.

TORQUE RANGE

48 - 7,924 ft.-lbs. / 65 - 10744 Nm

WEIGHT

7.20 - 26.50 lbs. / 3.27 - 12.05 kg

HEIGHT

7.32 - 8.46 in. / 186 - 215 mm

LENGTH

7.03 - 13.90 in. / 179 - 353 mm

RPM

55.0 - 1.5

jGun® SINGLE SPEED

Pneumatic Torque Tool

The jGun SINGLE SPEED is a great choice for air-powered industrial bolting. With an exceptional power-to-weight and a breakout force that overcomes corroded and damaged nuts, this tool takes over where impact guns and breaker bars don't cut it. The jGun SINGLE SPEED provides continuous power with no kickback to break out the nuts that other systems can't tackle. While impact guns have overwhelming vibration and noise, and have been banned on many job sites, the jGun SINGLE SPEED uses precision gearing and a simple reaction fixture to give you maximum power without the damaging noise and vibration.

- POWERFUL BREAKOUT
- REPEATABLE TORQUE
- ERGONOMIC DESIGN

FULL SPECIFICATIONS

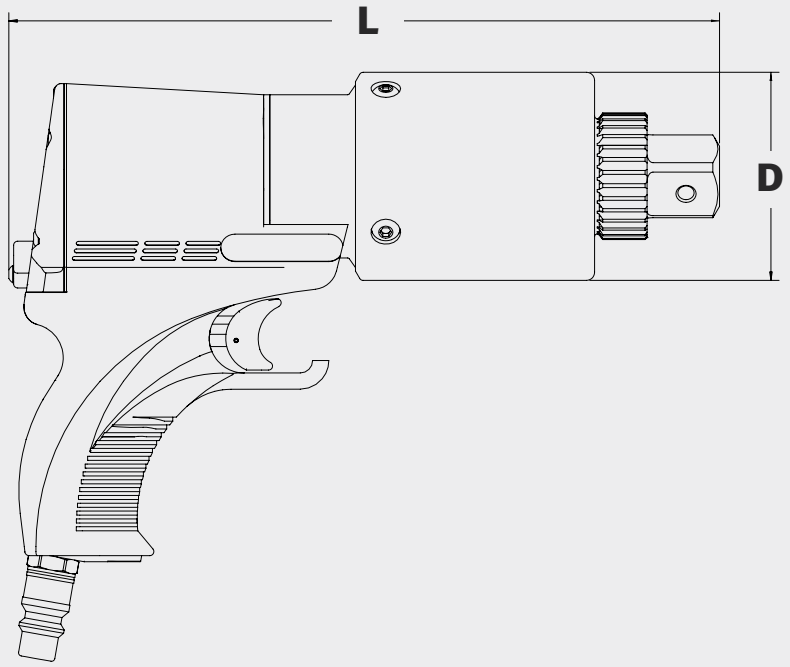
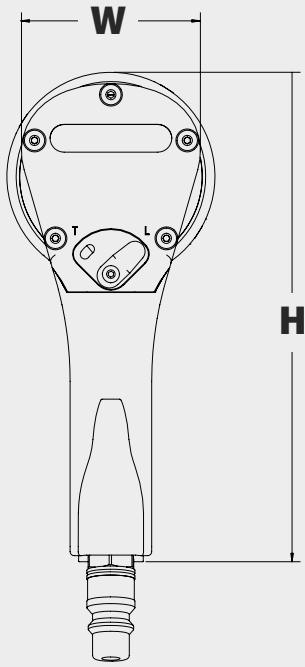

LEGEND: H = HEIGHT W = WIDTH L = LENGTH D = OUTER DIAMETER OF GEARBOX

MODEL NUMBER	H	W	L	D	SQUARE DRIVE	WEIGHT	TORQUE		RPM
IMPERIAL	in.					lbs.	ft-lbs (Min)	ft-lbs (Max)	
JGUN-A.25	7.32	2.74	7.03	2.50	3/4	7.20	48	250	55.0
JGUN-A.5	7.32	2.74	8.07	2.58	3/4	7.20	129	508	24.0
JGUN-A.7-HS	7.94	3.53	9.93	2.58	3/4	10.40	175	725	26.0
JGUN-A1	7.32	2.74	8.90	2.58	3/4	10.00	301	1,231	6.5
JGUN-A2	7.94	3.53	10.46	3.25	1	14.50	521	2,190	5.5
JGUN-A3	7.94	3.53	11.11	3.25	1	15.74	852	3,104	5.0
JGUN-A5	8.25	3.53	12.68	4.15	1-1/2	20.05	1,150	5,266	2.5
JGUN-A8	8.46	3.53	13.90	4.56	1-1/2	26.50	1,743	7,924	1.5

METRIC	mm				in.	kg	Nm (Min)	Nm (Max)	RPM
JGUN-A.25	186	70	179	64	3/4	3.27	65	339	55.0
JGUN-A.5	186	70	205	66	3/4	3.27	175	689	24.0
JGUN-A.7-HS	202	90	252	66	3/4	4.72	237	983	26.0
JGUN-A1	186	70	226	66	3/4	4.54	408	1669	6.5
JGUN-A2	202	90	266	83	1	6.58	706	2969	5.5
JGUN-A3	202	90	282	83	1	7.14	1155	4208	5.0
JGUN-A5	210	90	322	105	1-1/2	9.09	1559	7140	2.5
JGUN-A8	215	90	353	116	1-1/2	12.02	2363	10744	1.5

HYTORC owns all content, copyrights, trademarks and patents in this document. © 2023 HYTORC. Any unauthorized use or distribution of any material from this document is strictly prohibited.



Headquarters:
333 Route 17 N., Mahwah, NJ 07430
+1-201-512-9500

Contact:
1-800-FOR-HYTORC
info@hytorc.com

Online:
hytorc.com