

Hydraulic assembly

HY-VECTOR (automatic version)

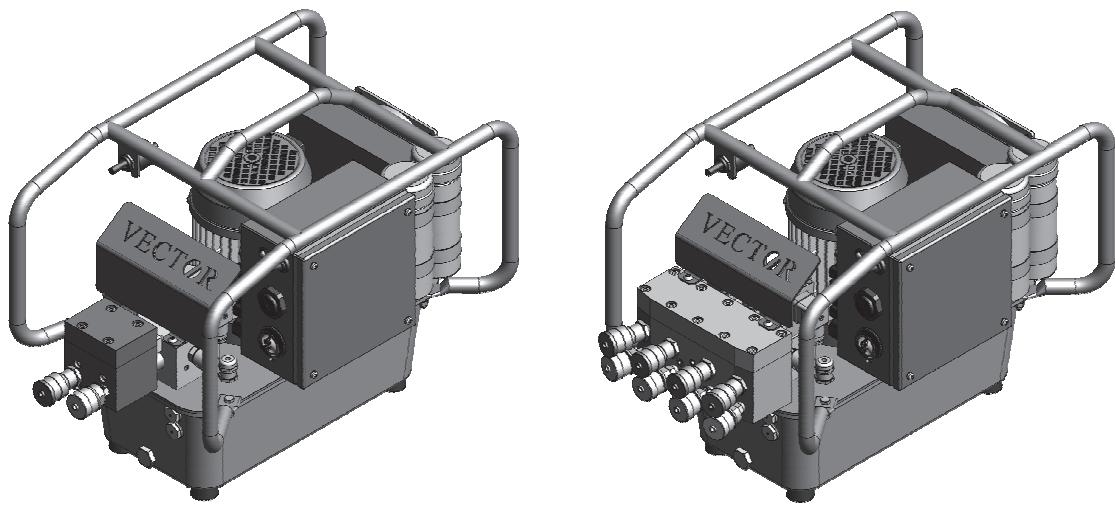

English translation of the original German manual

for qualified and authorized operating personnel

Last updated: 10/2020

Important safety instructions

Keep this manual in a safe place

Read and follow the operating manual before using the assembly

To reduce the risk of injury, you must be particularly careful when using the assembly near children.

Do not touch any moving parts.

Disregarding these safety instructions may result in injuries or even death.

Publisher HYTORC Technologies GmbH
Kleinbeckstr. 3-17
45549 Sprockhövel, Germany
Tel.: +49 (0) 23 24-90 77-0
Fax: +49 (0) 23 24-90 77-99
info@hytorctech.com
www.hytorctech.com

Document no. BA-0012-EN02

Revision no. 02

Document type Operating instructions

Issue date 2020-10-23

Copyright © 2020, HYTORC Technologies GmbH

All rights, including those of reprinting and reproduction of any parts of this document and its translation, are reserved by the publisher.

No part of this document may be reproduced in any form or copied using electronic reproduction systems without the written consent of the publisher.

We reserve the right to make technical changes in the course of further development.

Table of contents

Notes concerning this manual and the manufacturer	7
Keep the manual available	7
Design features of this manual	7
Current software state	7
Referenced documents.....	8
Manufacturer's address	8
Person responsible for documentation	8
Warranty and liability	9
Safety.....	10
Responsibilities of the operating company	10
Persons at particular risk	10
Qualification of personnel	11
Power supply connection	11
Tool connection	11
Setting pressure/torque	11
Assessing the state of the unit	11
Carrying the unit	12
Ban of unauthorized conversions	12
Personal protective equipment	13
Basic safety information.....	13
Preventing serious injury or death.....	13
Preventing explosion hazards	13
Preventing electric shock	14
Preventing burns from fire	14
Preventing burns from oil and hot surfaces.....	14
Preventing poisoning	15
Avoid fractures and contusions	15
Preventing eye damage	15
Preventing skin irritation	16
Preventing material damage.....	16
Intended use	16
Ambient conditions	16
Design characteristics of warning information	17
Design of information about property damage	18
Warning and information signs	19
Description.....	22
Directional data.....	22
Overview front right.....	23

Overview front left.....	24
Overview rear left.....	25
Overview of the hydraulic unit with one tool connection.....	26
Layout.....	27
Display and controls on the unit.....	27
LED.....	27
Toggle switch.....	28
Signal transmitter.....	29
USB port.....	30
Couplings.....	30
Displays and controls on the remote control.....	31
Display.....	32
Symbols in the display.....	32
Type plate.....	33
Available accessories.....	33
Workspaces and positions.....	34
Purpose and function.....	35
Unpacking and checking the delivery.....	36
Unpacking.....	36
Checking package and condition.....	36
Storing the unit.....	37
Carrying and setting down.....	38
Operating the software interface.....	39
Commissioning the unit.....	41
Initial commissioning.....	41
Fill hydraulic oil.....	41
Tool connection.....	43
Connect mains plug.....	44
Switch on unit.....	45
Perform basic settings with the remote control.....	45
Check oil level.....	48
Daily commissioning.....	49
Perform setting for the screwing case.....	49
Performing a test run.....	51
Operate software.....	52
User rights.....	52

User	52
Supervisor	52
Menu overview.....	53
Enter password.....	54
Opening a menu	54
Show information	54
Show information about system components	54
Display serial number	56
Display error log	56
Save system report.....	56
Show information about maintenance	56
Change settings.....	59
Setting the date format	59
Setting the date	60
Setting the time.....	60
Setting the language.....	61
Setting the torque unit	61
Set pressure unit	61
Reset to factory settings.....	62
Operating the unit.....	63
Changing tools	63
Perform system measurement.....	66
Change current order.....	67
Change the maximum torque of the current order	68
Perform screwing process manually.....	68
Perform screwing process automatically	69
Change password.....	70
Emergency stop has been pressed	71
Load tool data (tool files)	72
Firmware Update	75
Prepare update.....	75
Perform update.....	76
After use.....	78
Decommissioning the unit.....	80
Servicing the unit	81
Maintenance schedule.....	81
Changing the hydraulic oil	82
Replace oil filter	85

Replace oil filter (3 µm)	85
Replace oil filter (20 µm)	86
Cleaning the unit.....	87
Remedying faults or malfunctions	88
Table of faults	88
Replacing fuses	92
Prepare for fuse replacement.....	92
Replace 115 V/230 V fuse.....	93
Replace 400 V fuse	94
Disposal.....	95
In the USA	95
In Europe	96
Technical specifications	97

Notes concerning this manual and the manufacturer

These instructions help using the HY-VECTOR hydraulic unit safely.

The HY-VECTOR hydraulic unit is hereinafter referred to as "unit".

Keep the manual available

These operating instructions are a part of the unit. Make sure that the operating instructions are always accessible for the user at the site and are in legible condition. Enclose the operating instructions when you sell the unit or transfer it in any other way.

Design features of this manual

Various elements of these operating instructions are provided with specified design features. This allows you to easily distinguish the following elements:

Normal text

- Lists
 - Lists of second order
- ▶ Action steps

Table titles are printed in bold.

"Menu items" are in quotes

 Tips Contain additional information.

Current software state

Electrical control: 1.00.02

Remote control: 2.03.54

Referenced documents

⚠ WARNING	
	<p>Risk of injury from non-compliance with the applicable documentation.</p> <ul style="list-style-type: none">▶ Prior to working with the unit, read all applicable documents and comply with them.▶ These can be found in the documentation folder of the unit.

More information, instructions and details about the unit components can be found in the documentation from the respective manufacturers. These documents are regarded as a part of these instructions. Store these documents together with this manual. Hand over these documents when selling the unit or passing it on in other ways.

Applicable documents are especially the following document types:

- Operating instructions
- Assembly instructions
- Maintenance and repair manuals
- Circuit diagrams
- Terminal layouts
- Hydraulic layouts
- Safety data sheets
- Drawings
- Spare parts lists
- Declarations of conformity or declarations of incorporation
- ▶ Please heed and comply with the information from the applicable documents.

These can be found in the documentation folder of the unit.

Manufacturer's address

HYTORC Technologies GmbH
Kleinbeckstr 3–17
45549 Sprockhövel
Germany
Telephone: +49 (0) 23 24-90 77-0
Fax: +49 (0) 23 24-90 77-99
E-Mail: info@hytorctech.com
Web: www.hytorctech.com

Person responsible for documentation

HYTORC Technologies
Thomas Heitmann
Kleinbeckstr 3–17
D-45549 Sprockhövel
Germany

Warranty and liability

In general our General Terms and Conditions apply. Warranty and liability claims for personal injury or property damage are always excluded, if they are due to one or more of the following causes:

- Improper use of the unit
- Improper transport, installation, commissioning, operation and maintenance of the unit
- Ignoring the instructions in this manual
- Ignoring the hazard notices on the unit
- Unauthorized modifications of the unit
- Inadequate monitoring of components which are subject to wear
- Incorrectly executed repairs
- Disasters caused by outside intervention or an act of God

Safety

⚠ WARNING	
	<p>Severe injuries or death caused by accidents due to disregard of the instructions in this guide.</p> <p>In particular the failure to observe the instructions in the Chapter on Safety, can lead to accidents.</p> <p>▶ Read and follow all instructions in this manual before you begin working with or on the unit.</p>

In addition to the notes in these operating instructions, also follow, in any case, the statutory and other regulations, e.g.:

- Accident prevention regulations
- Regulations for safe and professional work
- The applicable on-site regulations for explosion protection and fire protection

Responsibilities of the operating company

- The operator must ensure that all accident prevention regulations are complied with.
- The operator must ensure that only qualified and authorized operating personnel performs work on and with the unit.

Persons at particular risk

The following groups of people cannot have access to the unit, since severe or deadly injuries are possible:

- Children
- People with physical or mental limitations
- People under the influence of drugs and/or medication
- People under the influence of alcohol
- Unauthorized persons such as passerby
- People without the qualifications specified in the following section

Qualification of personnel

These operating instructions are addressed to qualified and authorized operating personnel.

The following sections list the necessary qualification for each activity on or with the unit.

Power supply connection

The following skills and experience are required for the operating personnel:

- have been taught and trained for the work
- know that improper operation, maintenance and repairs can cause accidents
- can assess hazards that arise from electrical voltage and power
- can assess hazards that arise from noise and heat
- can provide the unit's power connection using the provided power cable

Tool connection

The following skills and experience are required for the operating personnel:

- have been taught and trained for the work
- know that improper operation, maintenance and repairs can cause accidents
- can assess risks and environmental damage that could be caused by hydraulic oil
- can assess risks that may arise from the high pressure components
- can assess hazards that arise from noise and heat
- can detect leaks
- can handle screw couplings to connect tools to the unit

Setting pressure/torque

The following skills and experience are required for the operating personnel:

- have been taught and trained for the work
- know that improper operation, maintenance and repairs can cause accidents
- can assess risks that may arise from the high pressure components
- can assess hazards that arise from noise and heat
- can set a predetermined pressure on the unit

Assessing the state of the unit

The following skills and experience are required for the operating personnel:

- have been taught and trained for the work
- know that improper operation, maintenance and repairs can cause accidents
- can assess hazards that arise from electrical voltage and power
- can assess risks and environmental damage that could be caused by hydraulic oil
- can assess risks that may arise from the high pressure components
- can assess hazards that arise from noise and heat

- can detect errors in the condition of the unit by performing a visual inspection prior to commissioning
 - Leaks
 - Kinks in electric lines
 - Kinks in hydraulic hoses
 - External damage to electrical lines
 - External damage to hydraulic hoses
 - Incorrect fill level in the unit

Carrying the unit

The following skills and experience are required for the operating personnel:

- have been taught and trained for the work
- can assess hazards that arise from improper carrying
- know that, with a weight of 25 kg, the unit is only permitted to be carried with the help of a second person.

Ban of unauthorized conversions

Unauthorized conversions or changes on the unit may lead to serious or even lethal injuries. This applies in particular to changing and altering safety devices.

- ▶ Never bypass or shunt any safety devices.

Personal protective equipment

Crushing of the feet when lifting and carrying the unit is possible!

- ▶ Wear safety shoes with steel toe caps.

Slipping and thereby risk of fractures when performing hydraulic work is possible!

- ▶ Wear safety shoes with non-slip soles.

Skin irritation and eye damage when in contact with hydraulic oil and hydraulic components is possible!

- ▶ Wear oil resistant nitrile gloves and chemical-resistant goggles.

Burns on contact with hot fluids and components are possible!

- ▶ Wear protective gloves against thermal risks.

Cuts and abrasions of the skin on sharp-edged components are possible!

- ▶ Wear protective gloves against mechanical risks.

Hearing impairments while unit is running are possible!

- ▶ In areas with high noise wear hearing protection.

Risk of poisoning possible in poorly ventilated rooms! The unit may overheat. In this case, oil mist and oil vapors can form.

- ▶ If this is the case, wear a respirator.

Basic safety information

Preventing serious injury or death

Avoid severe injury or death caused by failure of tools or hoses. Tools or hoses that do not match the tool and hose specifications may fail.

- ▶ Only use tools and hoses, which the manufacturer of the unit allows as an accessory.

Preventing explosion hazards

Operating and maintaining the unit in hazardous areas can lead to serious injury or death.

- ▶ Operate and service the unit only in areas where there is no explosive atmosphere.

Preventing electric shock

Severe injury or death from electrical shock is possible!

- ▶ Check the electrical supply line for damage.
- ▶ Use the unit only with immaculate lead.
- ▶ Immediately have a damaged electrical lines replaced by authorized personnel.
- ▶ Make sure that the ground wire connection (green yellow cable) on the unit is properly designed and properly connected.
- ▶ Connect the power plug of the unit only to a properly grounded electrical outlet with the correct electrical voltage and frequency.
- ▶ Unplug the power cord from the wall outlet before performing any electrical work on the unit or cleaning the unit. For this, only hold the plug.
- ▶ Only dry clean the unit. Do not clean the unit with a pressure washer, cold cleaner or water.
- ▶ Never immerse the unit in water or other liquids.

Preventing burns from fire

A short circuit could cause a fire and cause severe burns.

- ▶ When not in use and before any maintenance work pull the mains plug from the wall outlet. For this, only hold the plug.
- ▶ Remove all unneeded and flammable materials from the work area.
- ▶ Make sure that a fire extinguisher with powder or foam extinguishing agent is available.

Preventing burns from oil and hot surfaces

During and after operation, burns on metallic surfaces or from hydraulic oil are possible.

- ▶ When working on or with the unit wear protective gloves against thermal risks.

Preventing poisoning

The unit may overheat. In this case, oil mist and oil vapors can form.

- ▶ Make sure there is sufficient ventilation.
- ▶ In poorly ventilated areas and upon formation of oil mist and oil vapors, wear a respirator.
- ▶ Switch the unit off when it overheats.
- ▶ Allow the unit to cool down.
- ▶ With the help of a non-contact infrared thermometer, ensure that the unit is cooled down to 25 °C (77 °F).
- ▶ Check the unit for possible damage.
- ▶ Have the unit repaired, if damaged, by qualified personnel before recommissioning.

When fluids leak, proceed as follows:

- ▶ Wear temperature- and media-resistant gloves.
- ▶ Take up liquid spills immediately with a suitable binding agent and a rag.
- ▶ Dispose of the binding agent and rag environmentally correct.

Avoid fractures and contusions

Fractures and contusions are possible. The unit might fall, when unstable or during lifting and carrying. Slipping and thereby risk of fractures when performing hydraulic work is possible!

- ▶ Always set up the unit on a flat, solid and stable base.
- ▶ Secure the unit and tools against falling.
- ▶ When lifting and carrying the unit, wear safety shoes with steel toe caps.
- ▶ Wear safety shoes with non-slip soles when working on hydraulics.

Preventing eye damage

At pressures of more than 700 bar (10,000 psi) and operating the unit outside of the tool and tubing specifications can lead to bursting of the hydraulic hoses and spraying of hydraulic oil.

- ▶ Make sure that the permissible pressure defined by the manufacturer is not exceeded.
- ▶ Observe the tool and hose manufacturer's specifications.
- ▶ Observe and follow the operating instructions of the tools and hose specifications.
- ▶ Wear chemical-resistant goggles.

Preventing skin irritation

Contact with hydraulic oil may cause skin irritation.

- ▶ Always provide a strong and tight connection between the unit and hydraulic tools.
- ▶ Wear nitrile gloves at work where you might come in contact with hydraulic oil.
- ▶ Make sure that the permissible pressure defined by the manufacturer is not exceeded.
- ▶ Observe the tool and hose manufacturer's specifications.
- ▶ Observe and follow the operating instructions for the hydraulic tools.

Preventing material damage

- ▶ Avoid soiling the couplings by installing the protective caps and protective plugs when the couplings are not in use.
- ▶ Always set the hydraulic tool down safely.

Intended use

The unit is used exclusively for driving hydraulic assembly tools for screws and nuts in the commercial sector. With the screwing assembly tool, screw connections can be loosened or tightened with a predetermined torque.

Intended use also includes observing and following all instructions in this manual, especially the safety instructions. Any other use is considered to be improper and will void the warranty and liability claims.

Ambient conditions







Make sure that the unit is used under the following environmental conditions:

- Temperature range: -20 °C to +55 °C (-4 °F to 131 °F)
- Humidity non-condensing

Make sure that the unit is stored and transported under the following environmental conditions:

- Temperature range: -30 °C to +60 °C (-22 °F to 140 °F)
- Humidity non-condensing

Design characteristics of warning information

 DANGER	
	Sections with the word DANGER warn of imminent dangerous situations that lead to death or serious injury.
 WARNING	
	Sections with the word WARNING warn of imminent dangerous situations that may lead to death or serious injury.
 CAUTION	
	Sections with the word CAUTION warn of dangerous situations that may lead to minor or moderate injuries.

Special symbols may be used in the warnings, in addition to the general danger signs. These symbols indicate the possible danger. The meanings of the individual symbols are found in the following section.

Explanation of symbols



Hazard from electric shock



Slipping hazard from leaked media



Burning hazard, scalding hazard



Risk of eye damage due to splashing liquid



Risk of explosion and explosive media discharge

Design of information about property damage

ATTENTION!

These notes warn of situations that can lead to property damage and limited functionality.

Warning and information signs

- ▶ Make sure that all warnings and signs attached to the unit are clearly visible and legible.
- ▶ Replace damaged or lost warnings and signs immediately.

The following labels are affixed to the unit:

Warning or information sign

**WARNING: DO NOT USE
IN EXPLOSIVE ENVIRONMENT
(USE AIR PUMP INSTEAD)**

Meaning or explanation

The unit is not suitable for the use in explosive environments.

- ▶ Do not use the unit in an explosive environment.
- ▶ In an explosive environment, use an air-operated pump for driving the tools.

WARNING 
HIGH PRESSURE (10,000PSI)
STAY ALERT!
Do not Use in an Explosive
Environment!
(Use a HYTORC Air Pump Instead)
Only Tool Handler Should
Operate Remote Control!

The unit produces a high pressure (700 bar/10,000 psi)

- ▶ Do not use the unit in an explosive environment.
- ▶ In an explosive environment, use an air-operated pump from HYTORC for driving the tools.
- ▶ Do not leave the unit unattended during operation.
- ▶ The tool and remote control should be operated by the same person!
- ▶ Change the oil as required or after every major application.
- ▶ Use oil of Class 46.

**CHANGE OIL
AFTER EVERY
MAJOR USE!
(USE GRADE 46 OIL)**

**FOR TOOL OPERATOR
ONLY**

The remote control may only be operated by the tool user.

HYTORC – Recommendation
for Gaskets and Critical Applications
4 TOOL USE !
Decrease in Number of Passes.
Precision Load Control !

Recommendation of the manufacturer for seals and other critical applications:

When using four tools simultaneously.

- ▶ Reduce the number of cycles per workpiece and ensure in this way a more accurate pretension force.

Warning or information sign

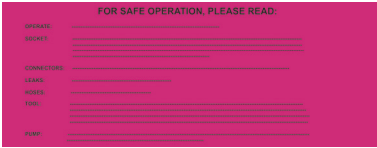

Meaning or explanation

Notes for safe use:

- ▶ Do not use the unit in a moist or an explosive environment.
- ▶ Do not use the unit with pressure probes.
- ▶ Only authorized operators can operate the unit.
- ▶ When working on the unit, use goggles and gloves.
- ▶ During operation, ensure that no persons are near the work areas.
Make sure that no unauthorized persons linger at the unit.
- ▶ During operation, keep distance from the tool and reaction arm.
- ▶ During operation, ensure that no body parts can be crushed on the tools.
- ▶ Do not touch moving parts during operation.
- ▶ Only use the unit when all connections and cables are in perfect condition.
- ▶ Make sure that the tools fit the connections. Plug and socket must exactly match.
- ▶ If possible, do not use any connections with thin bushes.
When using thin bushes during operation keep a distance from the connections.
- ▶ Ensure that plugs and jacks are securely connected.
- ▶ Connect the reaction arm with the tool.
- ▶ Set the reaction arm so that it is not pressed from the tool by the torque during operation.
- ▶ Set the reaction arm so that the tool cannot slip.
- ▶ Test the setting of the reaction arm at low pressure before use.
- ▶ During operating, hold the hydraulic hoses to the tool at their protection jackets.

The unit switches itself off automatically after 20 seconds in the return stroke position.

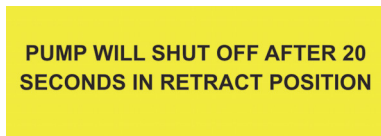

- ▶ Switch off the unit when not in use.

Warning or information sign



Meaning or explanation

Parts of the unit are under voltage during operation.

- ▶ Do not touch any electrical components of the unit during operation.



The unit is not suitable for the use in explosive environments.

Description

The hydraulic unit can be delivered with one or four tool connections. It is possible for you to expand an existing hydraulic unit with one tool connection to four tool connections. For this, please contact the manufacturer.

- ⓘ The illustrations and descriptions in this manual refer to a hydraulic unit with four tool connections. The hydraulic unit with one tool connection differs only in the number of tool connections. The guard plate is not shown in the illustration to provide a better overview.

Directional data

In this guide, the following directions are defined for the unit:

- Front: On the front side (B) you can see the couplings.
- Rear: On the rear side you will see the oil cooler fan.
- Right: On the right side you will see the electric control.
- Left: From the left side you see the side view of the electric motor and oil inlet opening.
- Top: On the upper side (A) you see the installed components
- Bottom: On the lower side the rubber feet are arranged.

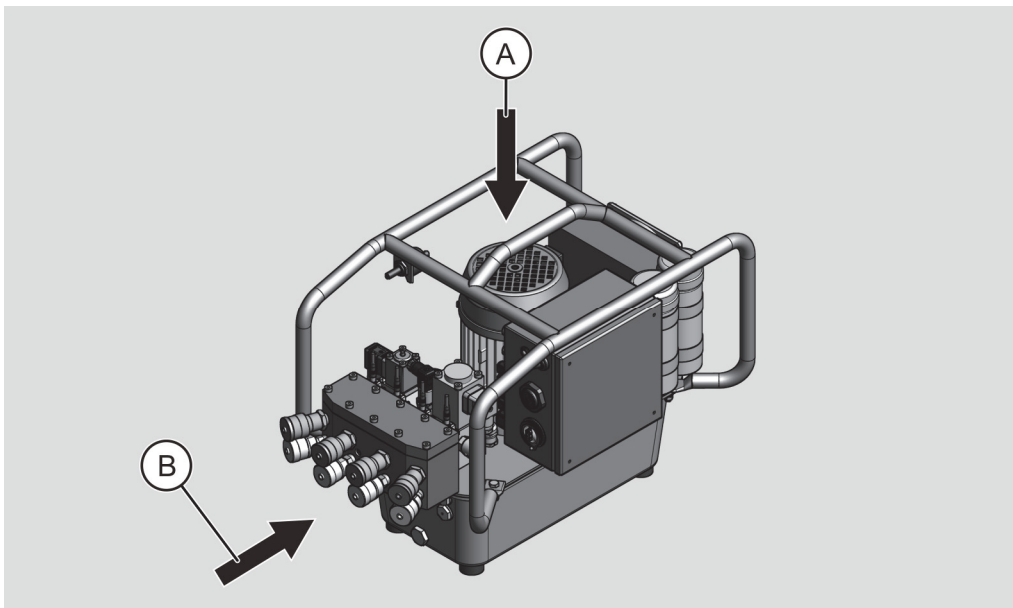

Overview front right

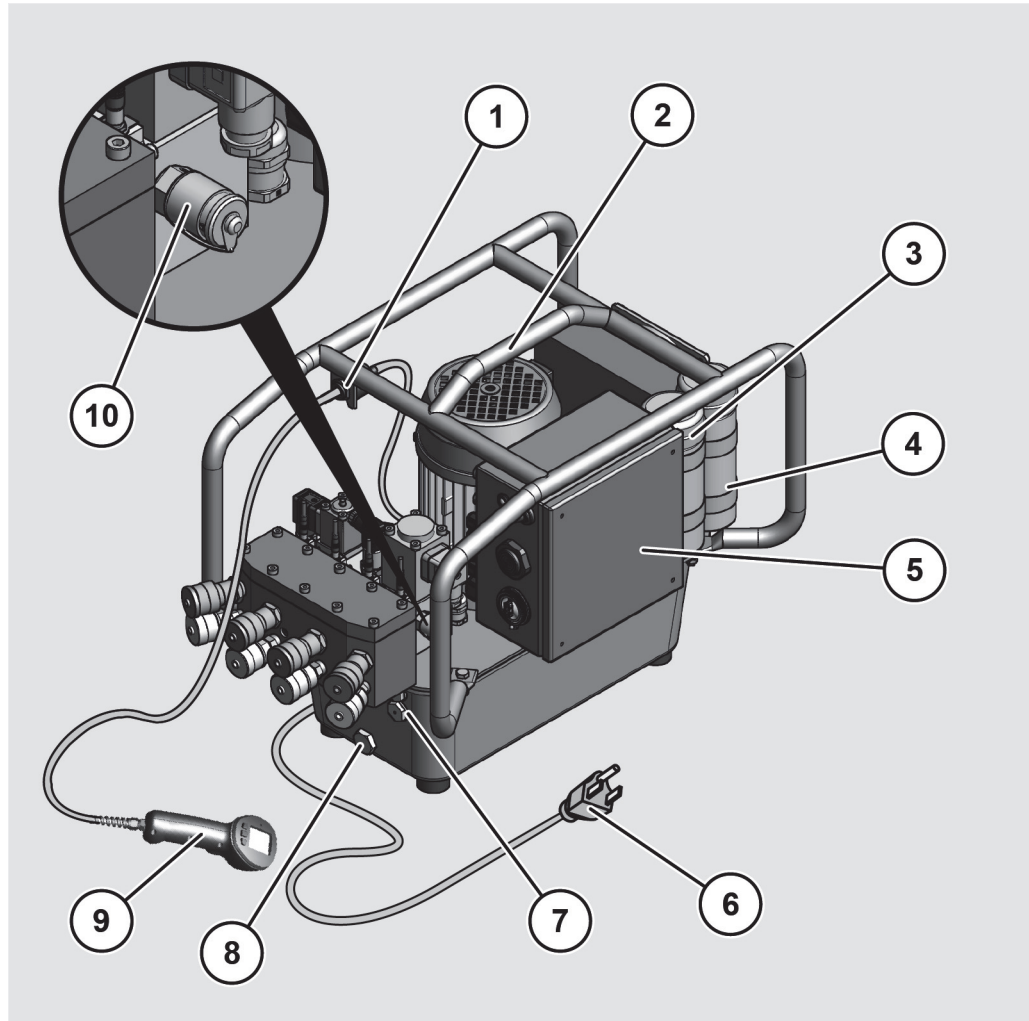

No.	Name
1	Tension relief
2	Bracket
3	Operating capacitor
4	Start capacitor
5	Electric control
6	Power plug (pictured 115 V-Version)
7	Sight glasses
8	Oil drain screw
9	Remote control
10	Minimum process connection for connecting a manometer

Overview front left

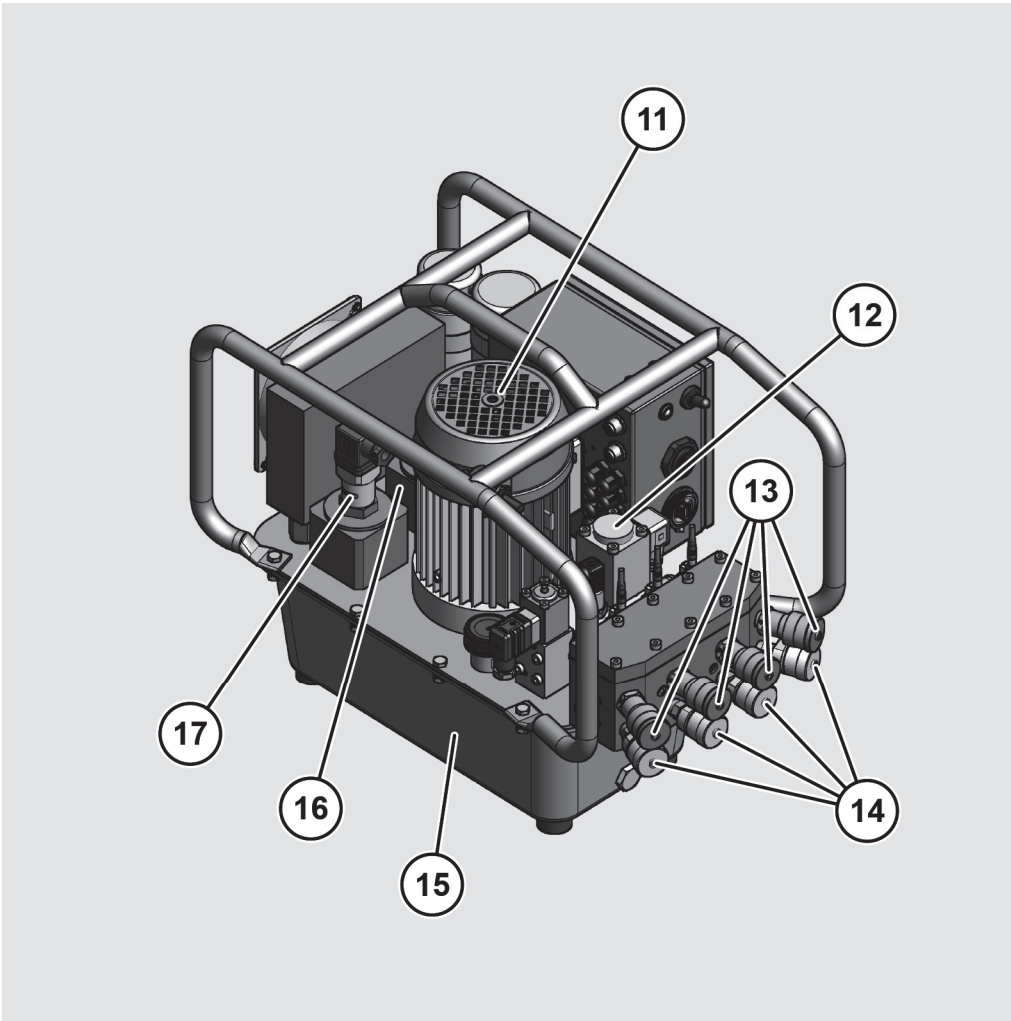

No.	Name
11	Electric motor of motor pump unit
12	Proportional pressure relief valve
13	Couplings (return stroke)
14	Couplings (forward stroke)
15	Oil container
16	Oil filter, coarse
17	Oil filter, fine with monitoring

Overview rear left

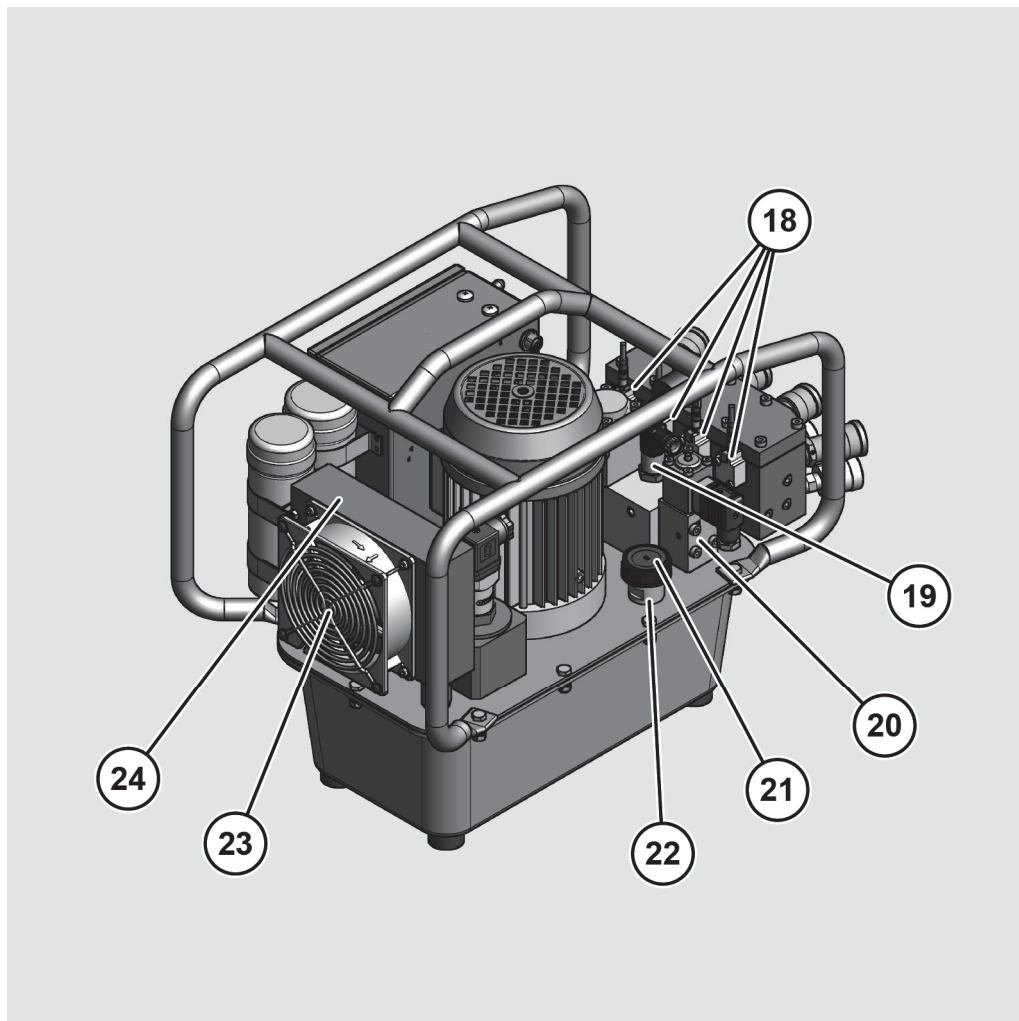

No.	Name
18	Measuring counter sensors
19	Pressure sensor
20	Solenoid valve
21	Ventilation and bleed valve
22	Oil fill opening
23	Oil cooler (fan motor)
24	Oil cooler (cooling body)

Overview of the hydraulic unit with one tool connection

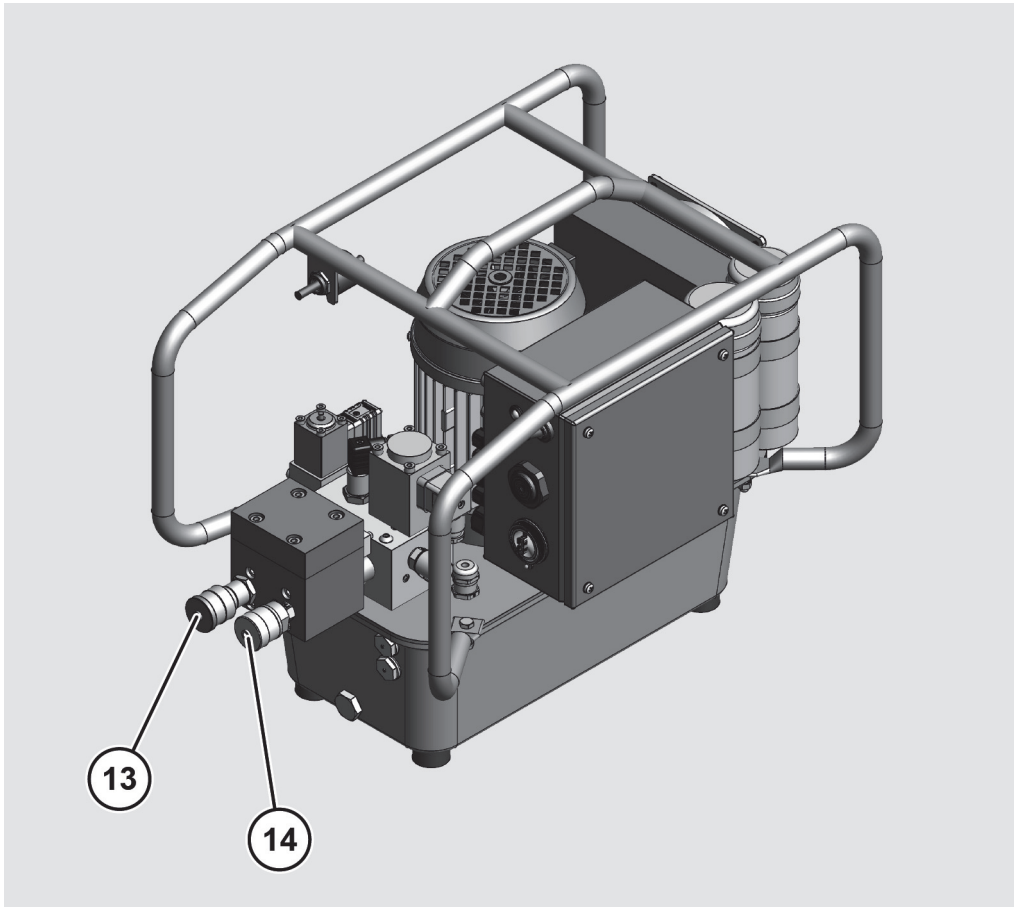

No.	Name
13	Coupling (return stroke)
14	Coupling (forward stroke)

Layout

The unit consists of the following main components:

- Electrical motor pump unit
- Oil container
- Valve block
- Oil cooler
- Filter black
- Couplings
- Bracket.

Display and controls on the unit

LED

A LED (25) is mounted at the side of the electrical control. It indicates the operating states.

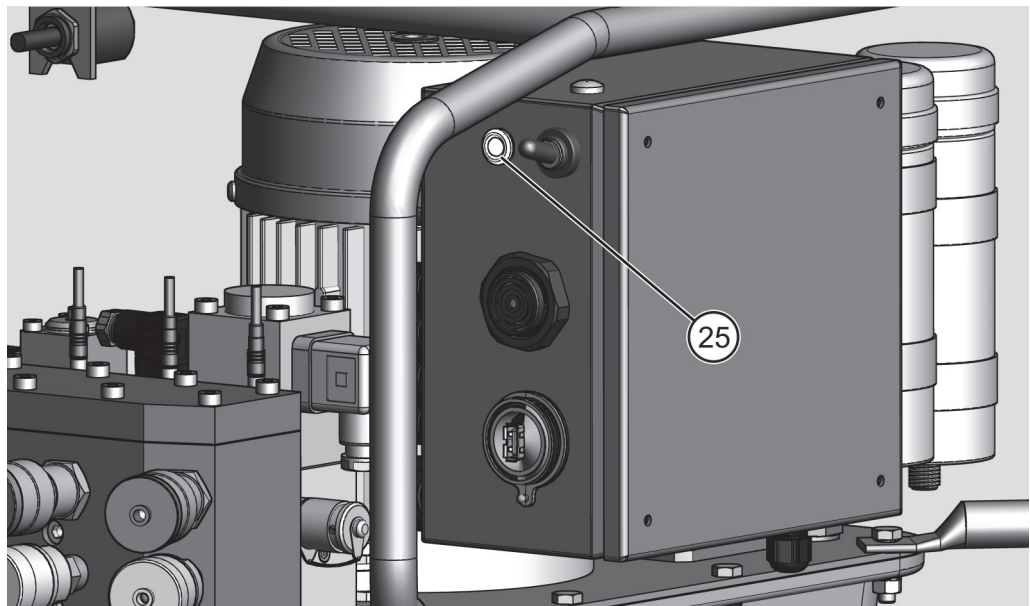

LED	Description
Pulsating, green	Initialization of system
Lights up green	Initialization completed successfully Unit is operational
Lights up red	Fault
Pulsing red twice cyclically	Only on 400 V Version: Wrong direction of rotation of the electric motor

Description

Toggle switch

A toggle switch (26) is mounted at the side of the electrical control. It is used to switch the pump on and off.

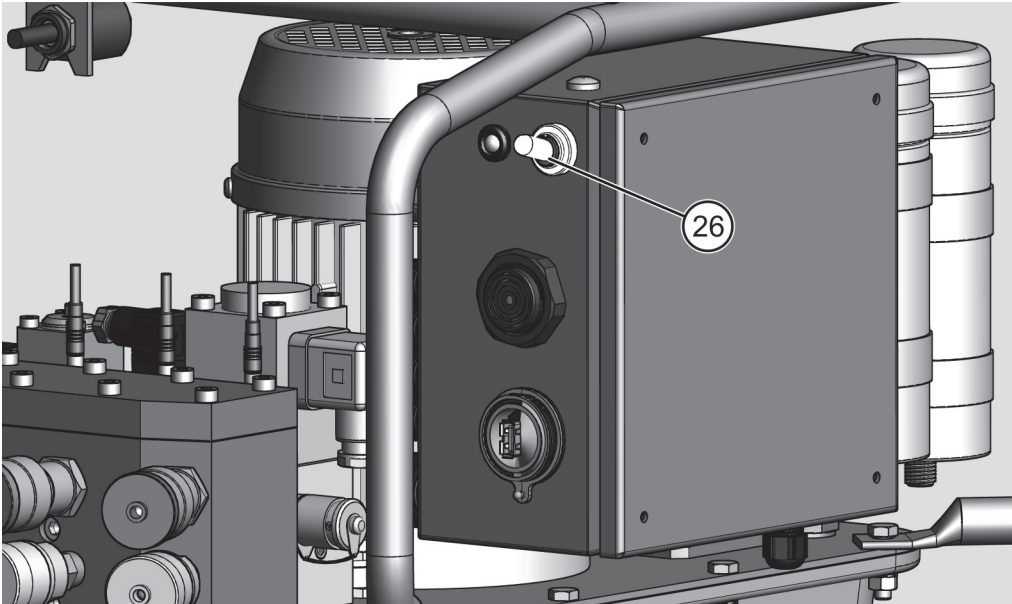

Switch positions	Description
up	The pump is switched off.
down	The pump is switched on.

Signal transmitter

An acoustic signal generator (27) is mounted at the side of the electric control. A beep is used as signal.

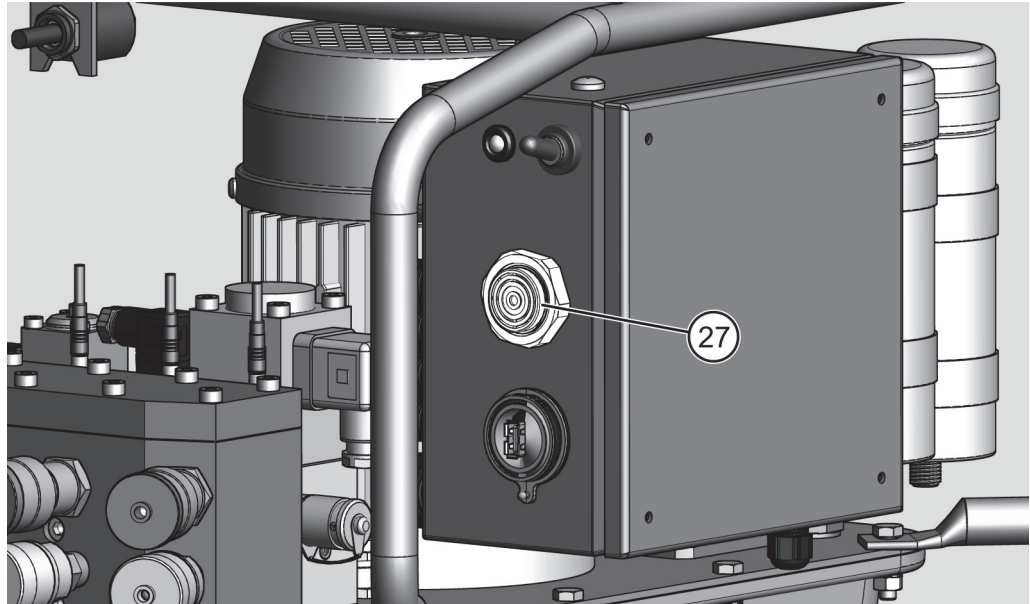

Signal	Description
Short beep (duration about 50 ms)	The initialization process is completed. The unit is ready for operation.
Beep	The trigger on the remote control is pressed. The screwing operation has been completed successfully in fully automatic mode.

Description

USB port

A USB port (28) is located at the side of the electric control. Updates to the Firmware and Software can be performed via this USB port.

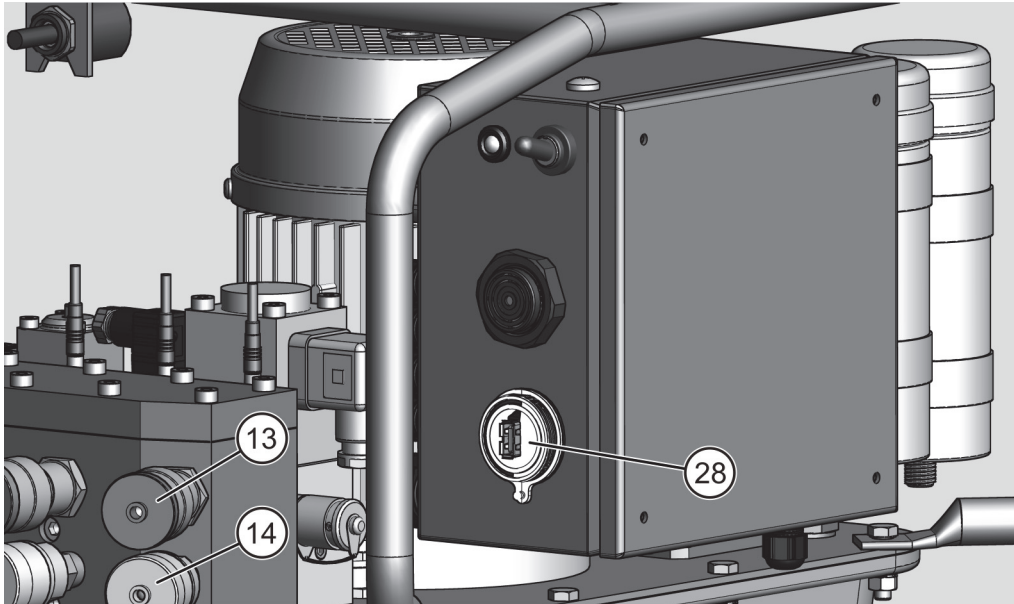

Couplings

The couplings (13, 14) are arranged on the front side of the unit. The couplings are used to connect the tools. Using screw caps provides a tight connection between the tool and the unit.

Displays and controls on the remote control

The remote control is used for the following:

- Adjusting the parameters necessary for the screwing process e. g. type of screw tool, torque
- Operation of the unit and connected tools.

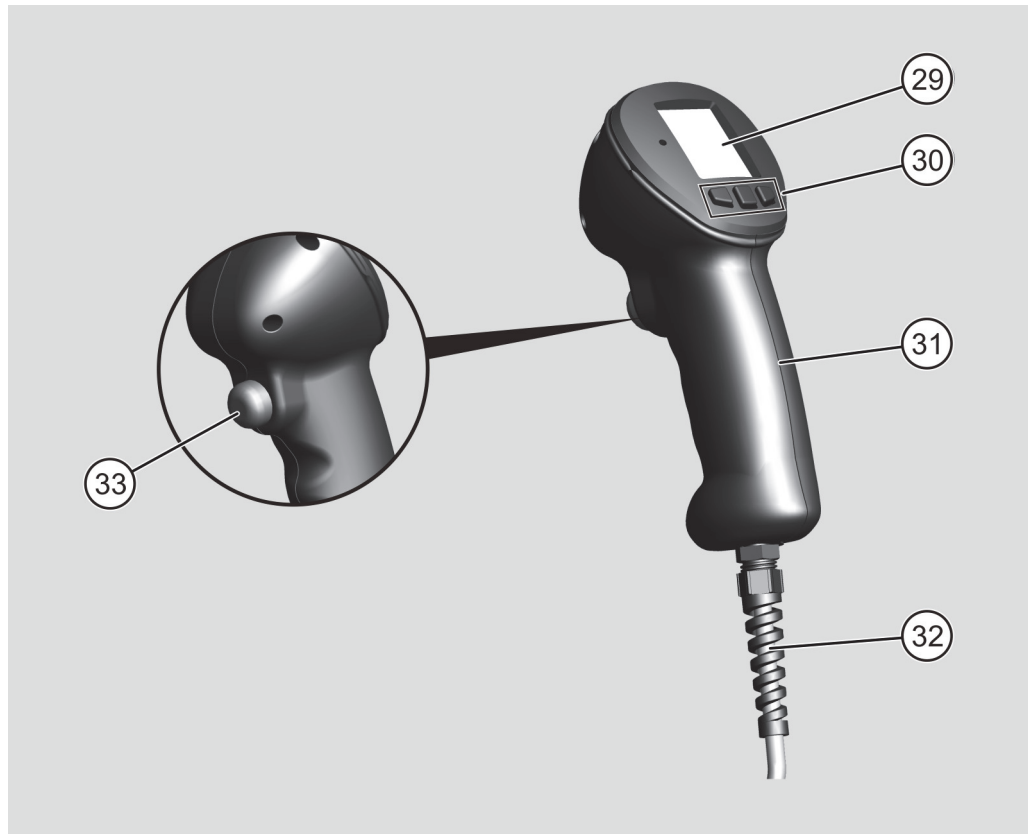

No.	Name
29	Display
30	Buttons for operating the display content
31	Handle
32	Connection cable
33	Button (Trigger) to perform the screw process, confirming settings in the display



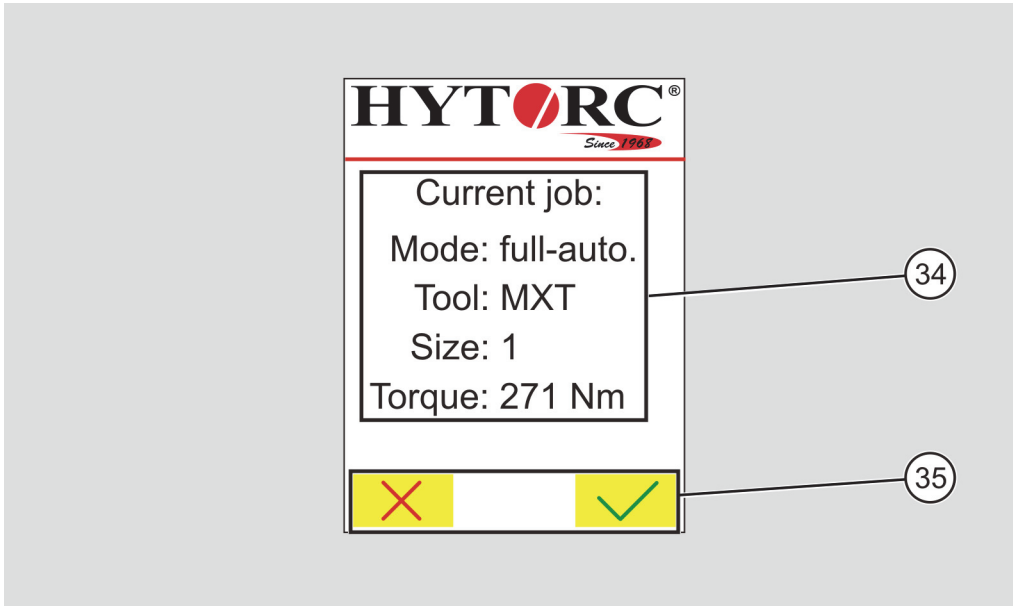







Display



No.	Name
34	Display area e. g. for the selection of the screwing tool
35	Display elements to set parameters

Symbols in the display

Symbol Description

	Upward Increase value
	Downward Decrease value
	Return
	Continue
	One menu level up
	Open the Settings menu (password required)
	Switch off motor
	Delete entry
	Abort
	Confirm
	Trigger Emergency stop

Type plate

The type plate may be attached as a sticker on the top of the electric control or on the cover next to the solenoid valve. The type plate contains the following information:

- Name of distributor
- Name of the model
- Serial number
- Electrical voltage
- Output
- Operating mode
- Name of manufacturer
- Manufacturer country

Available accessories

The following tools are available as accessories:

- Square torque wrenches
- Box wrench torque wrench
- Fitting systems.

Workspaces and positions

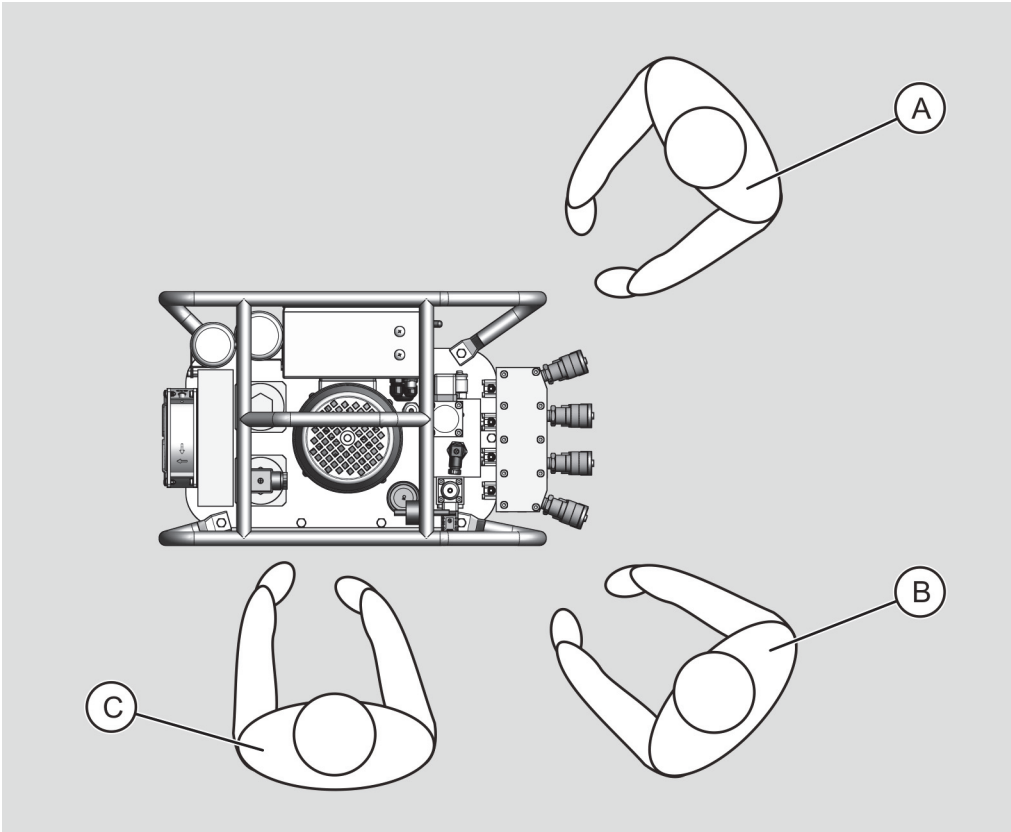

Pos.	Name
A	Connect tools, press main switch, drain oil
B	Connect tools, drain oil
C	Add oil

Purpose and function

The unit is used to drive hydraulic screwing tools.

Up to four screwing tools of the same type can be connected simultaneously to the existing eight couplings. The top four couplings are designed as female connectors and take care of the return stroke of the connected screwing tools. The bottom four couplings are designed as male connectors and take care of the feed stroke of the connected screwing tools.

The unit is equipped with an electric control. This control monitors the operation and controls the connected actuators and indicators on the unit and the remote control. All the data required for the screwing process of the HYTORC screwing tools are stored in the electric control. To be able to keep the data up to date, it is possible to perform updates via a USB stick.

 The unit is not suitable for operation with screwing tools from other manufacturers.

The torque required for the screwing operation is set with the remote control. The electric motor pump unit produces the hydraulic pressure that is necessary for applying the required torque on the connected screwing tool. The maximum reachable pressure is 700 bar and is limited by a proportional pressure relief valve.

The actual pressure at the connections of the valve block are constantly monitored by sensors. Pressure changes, e.g. by heating of the oil during operation, are automatically compensated by the electric control, and the proportional pressure-limiting valve.

To check the actual pressure, a pressure gage can be connected to the mini-measurement process connection.

During operation, the oil is passed through the existing oil cooler where it is cooled. A coarse oil filter and a downstream fine oil filter with monitoring are provided to keep the oil clean.

Unpacking and checking the delivery

Unpacking

The unit is supplied in a cardboard box. To unpack the unit, proceed as follows:

- ▶ Open the cardboard box.
- ▶ Remove the supplied documents.
- ▶ Remove the foam padding.

The unit is packaged in a plastic bag.

- ▶ Take the unit out of the box and place it on a flat, solid and stable base.
- ▶ Remove the plastic bag.
- ▶ Dispose of the packaging material according to the rules and regulations applicable on site.

Checking package and condition

- ▶ Check the delivery against the delivery note for accuracy and completeness.
- ▶ In case of deviations contact the manufacturer.
- ▶ Check the delivery for any damage.
- ▶ If you notice any damage, please indicate this on the delivery note.
- ▶ Have the damage confirmed by the signature of the supplier.
- ▶ Photograph the damage.
- ▶ Report the damage immediately to the manufacturer.

Storing the unit

- ▶ Store the unit standing on its feet in a dry, dust-free room with stable temperature.

The permissible temperature range is -30 °C to $+60\text{ °C}$ (-22 °F to $+140\text{ °F}$).

The humidity should not be condensing.

Carrying and setting down

CAUTION



Muscularity injuries caused by the weight of the unit.

- ▶ Never carry more than 25 kg (55 lbs).
- ▶ Carry the unit with two people.

- ▶ Carry the unit only on the carrying handle.
- ▶ Always place the unit on a flat, solid and stable base.
- ▶ Secure the unit and associated tools against falling.

Operating the software interface

The operation of the software user interface is done using the remote control of the unit.

The remote control is the central control element of the unit. You are able to perform the following actions and processes using the controls on the remote control:

- Operating the software
- Define settings for screwdriving
- Perform screwdriving.

The three buttons (30) below the display allow you to perform actions that are displayed directly above in the display as an icon. For an overview of the icons and their function see page 32.



These symbols are also used in the instructions of this manual, e.g.:

► Press .

To perform this action, press once and release the button (30) located directly below the icon on the remote control and .

The green button (33) on the back of the remote control is used to confirm entries and to perform the screwing process.

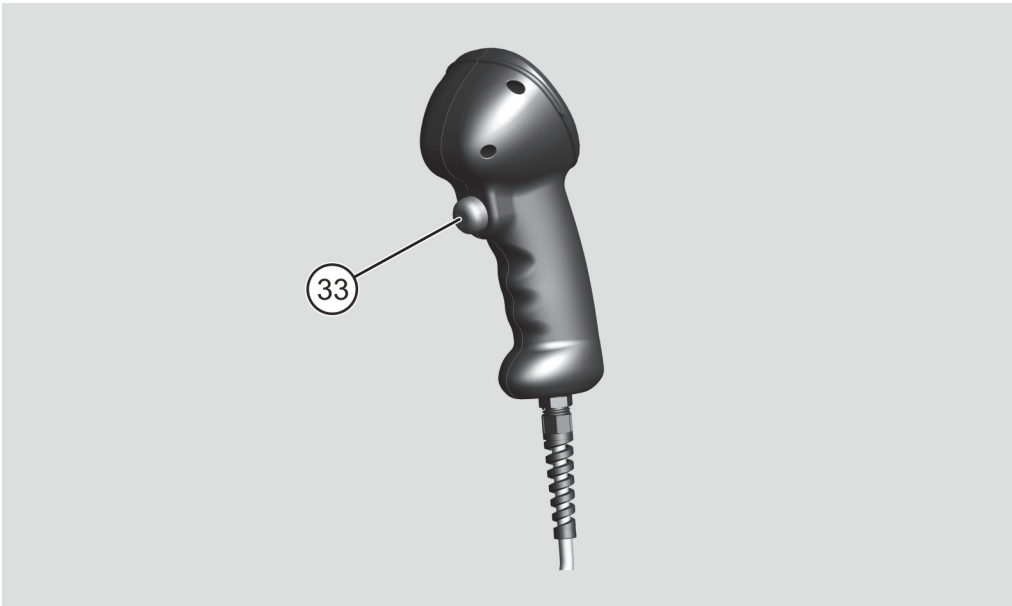

During initial commissioning, the software retrieves some information. With the instructions about operation provided here, you can start the initial commissioning. For more information about the software, see page 52.

Commissioning the unit



When commissioning the unit, we distinguish between the initial commissioning and daily commissioning. Depending on the type of commissioning, you must perform different work tasks.

Initial commissioning

If you want to take the unit in operation for the first time after delivery, you will have to first perform the following tasks:

- Fill hydraulic oil
- Remove protective caps and plugs and connect tools
- Connect mains plug
- Switch unit on using the toggle switch
- Perform basic settings with the remote control
- Bleed screw system
- Check oil level.

Fill hydraulic oil

⚠ CAUTION	
	<p>Health hazard from contact with hydraulic oil.</p> <ul style="list-style-type: none"> ▶ Wear nitrile gloves and chemical-resistant protective goggles during work that may include contact with hydraulic oil.
⚠ CAUTION	
	<p>Risk of slipping due to leaked oil.</p> <ul style="list-style-type: none"> ▶ Take up spilled oil with a suitable binder agent. ▶ Wear safety shoes with non-slip soles.
ATTENTION!	
	<p>The use of hydraulic oils that do not meet the manufacturer's recommendation may cause damage to the unit. Warranty claims can become invalid.</p> <ul style="list-style-type: none"> ▶ Only use hydraulic oil recommended by the manufacturer.

 The manufacturer-approved oils can be found starting on page 97.

Commissioning the unit

To fill the hydraulic oil in the oil tank of the unit, proceed as follows:

- ▶ Make sure that the unit stands securely on a flat surface.
- ▶ Remove the bleed and ventilation valve (21) of the unit's filling opening.

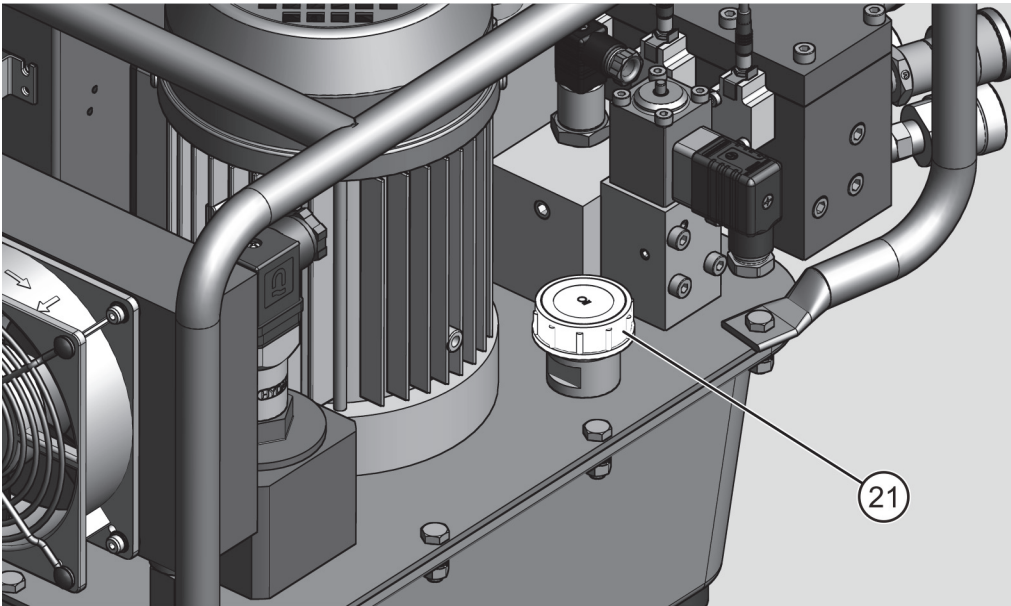

- ▶ Slowly fill fresh hydraulic oil into the oil container until the oil fills the upper sight glass half up.

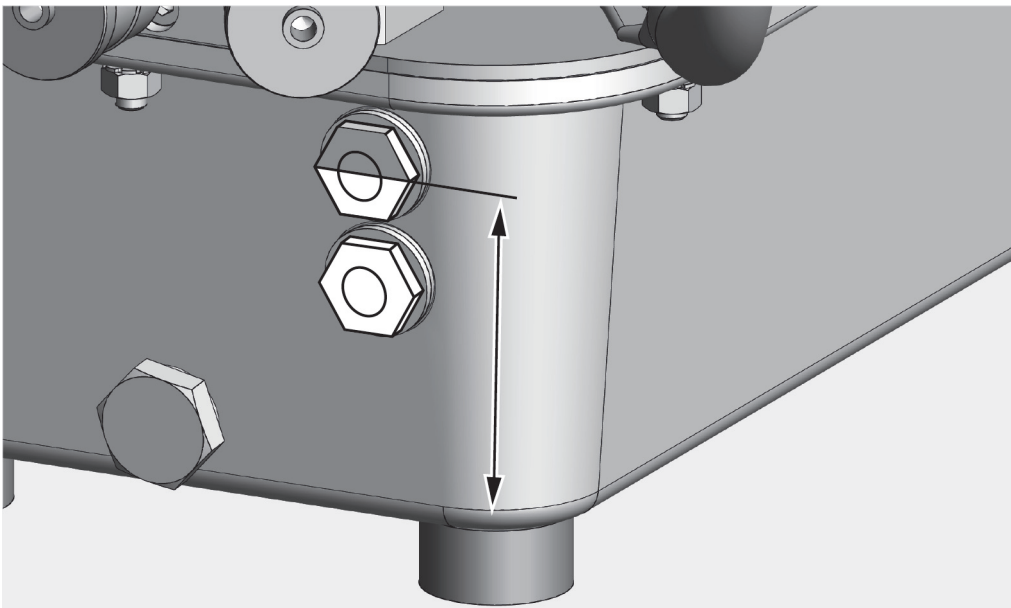

- ▶ Put the bleed and ventilation valve on the filler opening.
- ▶ Tighten the bleed and ventilation valve by hand.

Tool connection

⚠ WARNING



Risk to life when using tools or hydraulic hoses that do not comply with the tool and hose specifications.

Unsuitable tools or hydraulic hoses can fail.

- ▶ Only use tools and hydraulic hoses which the manufacturer of the unit allows as an accessory.
- ▶ Observe and follow the operating instructions of the tools and the hose specification.

Before you can connect a tool, you have to remove the protective cap and the protective plug of two stacked couplings. Proceed as follows:

- ▶ Screw the protective plug (A) counterclockwise from the corresponding connection (13).
- ▶ Screw the safety cap (B) counterclockwise from the corresponding connection (14).

The protective cap and the protective plug are permanently connected to the corresponding coupling.

You can now connect a tool.

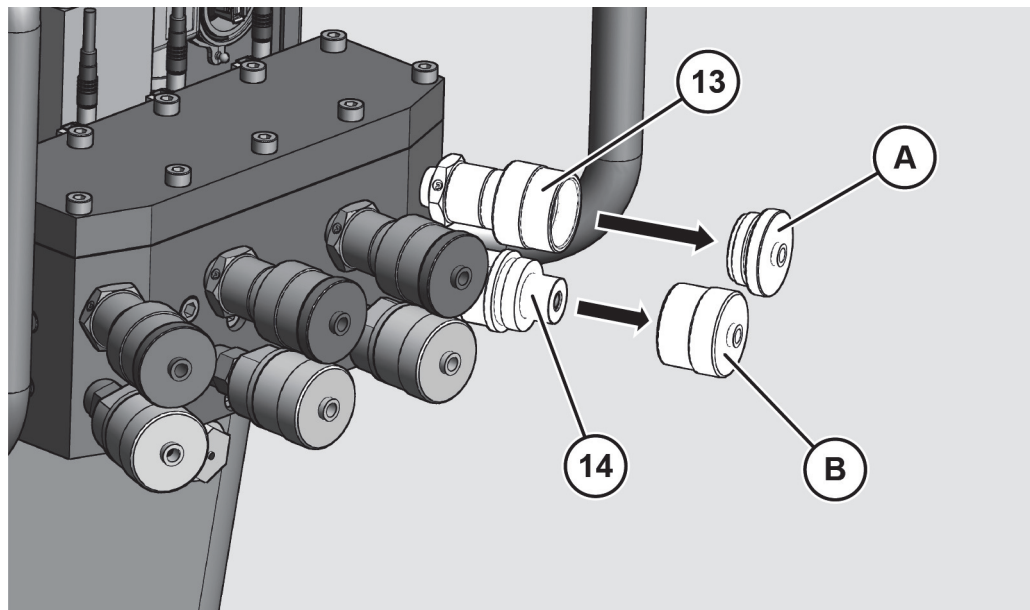

To connect a tool to the unit, proceed as follows:

- ▶ Ensure that the hydraulic hoses are not damaged.
- ▶ Plug the male connector (A) on the hydraulic hose of the tool on the female connection (13) of the unit.

Commissioning the unit

- ▶ Screw the connection with the union nut hand-tight.
- ▶ Plug the female connection (B) on the hydraulic hose of the tool on the male connection (14) of the unit.
- ▶ Screw the connection with the union nut hand-tight.

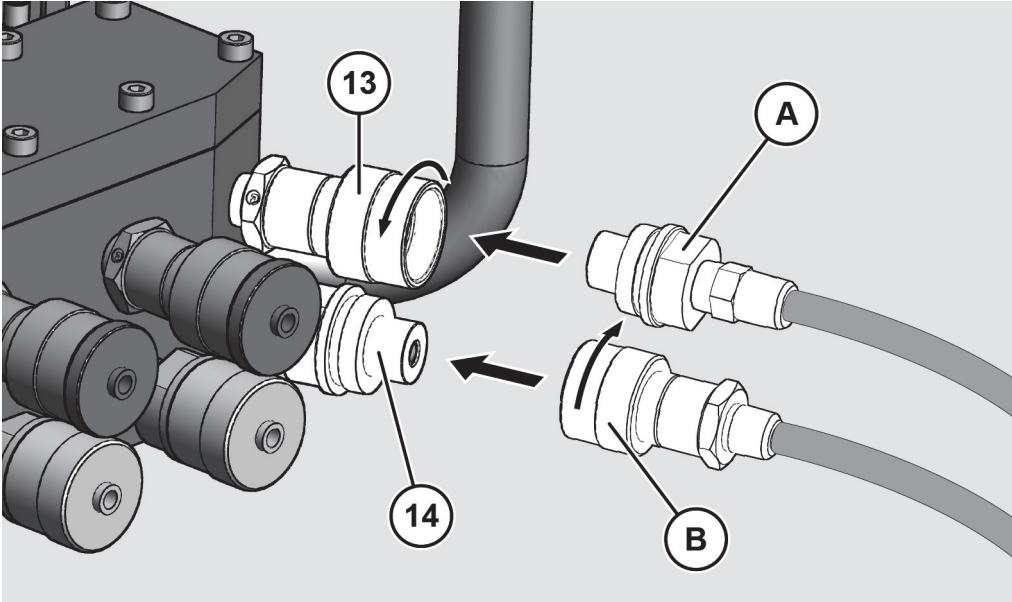

Connect mains plug

⚠ CAUTION	
	<p>Risk of injury due to tripping over the power cable.</p> <ul style="list-style-type: none"> ▶ Lay the power cable so that it does not pose a tripping hazard.
ATTENTION!	
	<p>Damage caused by connecting the unit to the mains outlet with incorrect electrical voltage and frequency. Incorrect electrical voltage and frequency destroys the electrical control.</p> <ul style="list-style-type: none"> ▶ Make sure that the unit is only connected to a suitable grounded electrical outlet.

The voltage and frequency of the mains socket must match the information on the unit's type plate.

- ▶ Ensure that the power cable is not damaged.
- ▶ Connect the power plug of the unit only to a suitable grounded electrical outlet.

Switch on unit

⚠ CAUTION	
	<p>Injuries caused by the ejection of the screwing tool from the screw connection.</p> <ul style="list-style-type: none">▶ Prior to switching on the unit, place the closed screwing tool on the ground.▶ Make sure that no unauthorized persons are in the work area.

To switch on the unit, proceed as follows:

- ▶ Switch the toggle switch on the electric control in the lower position.

The green LED flashes during the initialization.

On the remote control's display the "Initialization" is displayed.

The green LED lights up upon successful completion of the initialization process.

Perform basic settings with the remote control

After switching on the unit during the initial commissioning, make the following basic settings:

- Language
- Date
- Time
- Unit for the torque
- Unit for the pressure

The control of the unit queries the remote control display for the appropriate settings. These settings are also required when the unit has been reset to the factory settings.

After the initialization process the language selection is shown on the display.

You can now set the language to "German", "English" or "Dutch".

- ▶ With the  or  select the respective language.

The entry is highlighted in red.

- ▶ Press the green button.



The language is set.



Commissioning the unit

After setting the language, a date is displayed.

You can set the day, month and year. The changeable entry is displayed in red.

- ▶ To set the value for the day, press the corresponding button repeatedly.
- ▶ To decrease the value, select .
- ▶ To increase the value, select .
- ▶ To switch to the previous entry, select .
- ▶ Confirm your settings using the green button.

The unit is set.



The month is shown in red and can be adjusted.

- ▶ Set the month and then the year as previously described.



After setting the date, a time is displayed.

You can set the hours, minutes and seconds. The changeable entry is displayed in red.

- ▶ To set the value for the hour, press the corresponding button repeatedly.
- ▶ To decrease the value, select .
- ▶ To increase the value, select .
- ▶ To switch to the previous entry, select .
- ▶ Confirm your settings using the green button.

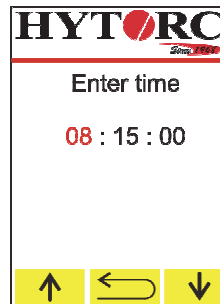

The minutes are shown in red and can be adjusted.

- ▶ Set the minutes and then the seconds as previously described.



After setting the time, you will be shown the selection of the unit of the torque value in the display.

You can set Newton meters (Nm), Foot-pound (ft.lbs.) or Kilo-pondmeter (kpm).

- ▶ With the  or , select the respective unit.

The entry is highlighted in red.

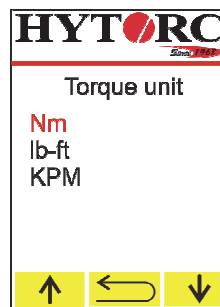

- ▶ Press the green button.

The unit is set.



After setting the unit for the torque value, you will be shown the selection of the unit for the pressure in the display.

You can now set "BAR" or "PSI".

- ▶ With the  or , select the respective unit.



The entry is highlighted in red.

- ▶ Press the green button.

The unit is set.



The initialization is completed, the unit is ready for use.

- ▶ To define a new screwdriving process, select , see page 49.
- ▶ To open the "Settings" menu, select .



WARNING



Risk of injury from components that have been attached with the wrong torque. Caused by illegal change of settings in the software.

- ▶ Change the passwords for the different user rights directly after the first commissioning.
- ▶ Make sure that only adequately qualified staff receive the password to change the settings.

- ▶ Change the passwords immediately after the first commissioning, see page 70.

Check oil level

To check the oil level, proceed as follows:

- ▶ Make sure that the unit is secure on a load-bearing, solid and flat surface.
- ▶ Check if the hydraulic oil is visible in the upper sight glass.
- ▶ Ensure that the hydraulic oil is clear and not white in color.

If the hydraulic oil is colored white, water has entered into the hydraulic oil.

- ▶ In this case, you need to change the hydraulic oil.
- ▶ When the hydraulic oil is not visible in the upper sight glass, top up fresh hydraulic oil recommended by the manufacturer, as described on page 41.

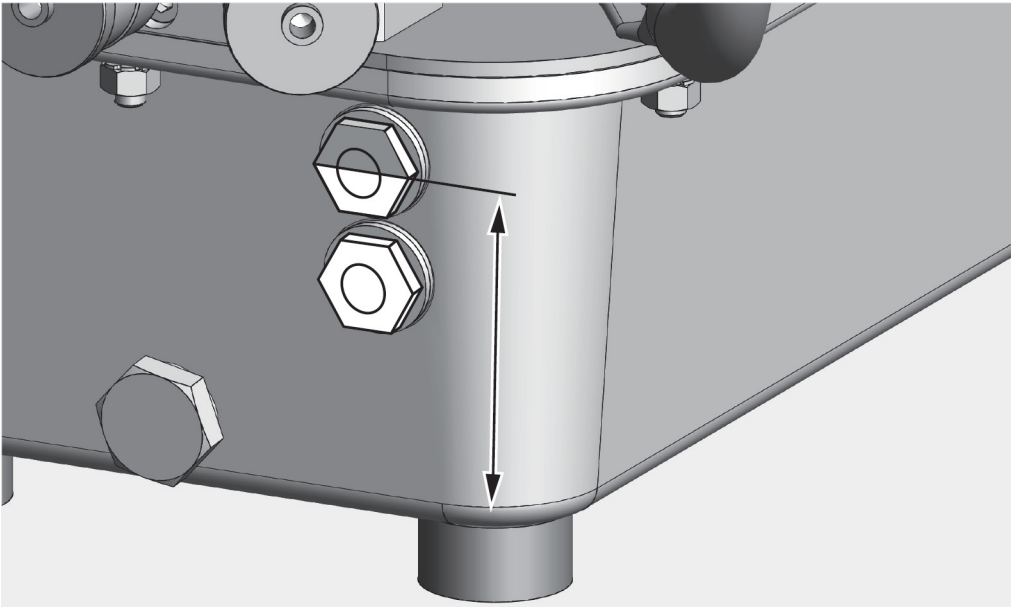

Daily commissioning

You must carry out the following work if the unit is put into operation daily:

- Check the power cable and remote control, including buttons and protective caps, to ensure they are in a perfect condition
 - Remove the protective caps and plugs and connect the tools; see page 11.
 - Connect the mains plug; see page 44.
 - Switch on the assembly using the toggle switch; see page 45.
 - Check the oil level; see page 48.
 - Make settings for the screwing case.
- ▶ Only use an assembly in a perfect condition.

Perform setting for the screwing case

To define the screwing case, proceed as follows:

- ▶ Select .

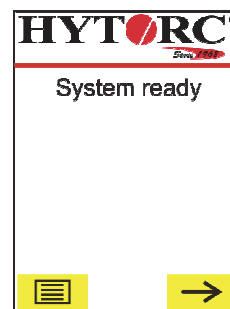

You can accept the existing settings or change the settings.

- ▶ To accept the settings, select .



Once you apply the changes, you can perform the screwing process.

- ▶ To change the settings, select .



In manual mode, perform the screwing process step by step, see page 68.

In automatic mode, the screw driving process is performed automatically, see page 69.

- ▶ With the  or  select the respective entry.

The selected entry is displayed in red.

- ▶ Confirm your selection using the green button.



Commissioning the unit

To set the appropriate screwing tool for screwdriving, proceed as follows:

- ▶ To display the next available screwing tool, choose **→**.
- ▶ To display the previous screwing tool, choose **←**.
- ▶ To open return to the "Change parameter" menu, select **↩**.
- ▶ To accept the displayed screwing tool, confirm the selection with the green button.

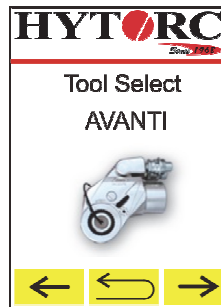

To set the appropriate size of the screwing tool for screwdriving, proceed as follows:

- ▶ To show the next size of the screwing tool, select **→**.
- ▶ To show the previous size of the screwing tool, select **←**.
- ▶ To switch to the selection of the screwing tool, select **↩**.
- ▶ To accept the displayed size of the screwing tool, confirm the selection with the green button.

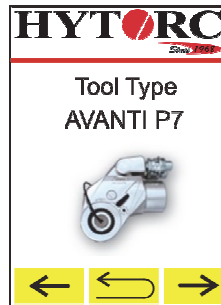



To set the appropriate torque value for screwdriving, proceed as follows:

- ▶ To set the value in smaller increments, press the corresponding button repeatedly.
- ▶ To change the value continuously press and hold the respective button.
- ▶ To decrease the torque value, select **↓**.
- ▶ To increase the torque value, select **↑**.
- ▶ To switch to the selection of the screwing tool, select **↩**.
- ▶ To accept the displayed torque values, confirm the selection with the green button.



Performing a test run

After each commissioning and after each tool change perform a test run. This ensures that no oil leaks occur and all components are functioning correctly. Proceed as follows:

- ▶ Set the manual screwing mode.
- ▶ With the  or , select the respective entry.

The selected entry is displayed in red.

- ▶ Confirm your selection using the green button.
- ▶ Perform the system measuring as described starting on page 66.
- ▶ Leave the screwing tool laying on the ground.
- ▶ Press the green button and hold it until the screwing tool is retracted.
- ▶ Release the green button.

The screwing tool moves back in its original position.

- ▶ Repeat the process until the connected screwing tool moves forward and backward without interruption.
- ▶ Check the unit and connected tools for proper function.
- ▶ Check the unit and connected tools for visible leaks.
- ▶ Use only a unit that is working properly and has no leakage.
- ▶ Use only tools according to manufacturer recommendation, which function properly and have no leakage.
- ▶ If oil leaks exist, determine the cause and have them eliminated.

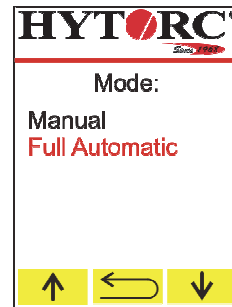

Operate software

User rights

The unit's control distinguishes between two types of user groups with different user rights:

- User
- Supervisor

⚠ WARNING	
	<p>Risk of injury from components that have been attached with the wrong torque. Caused by illegal change of settings in the software.</p> <ul style="list-style-type: none">▶ Change the passwords for the different user rights directly after the first commissioning.▶ Make sure that only adequately qualified staff receive the password to change the settings.

- ▶ Change the passwords immediately after the first commissioning, see page 70.

User

The users have access to all functions that are required to performing screwing. Some of these functions are password protected due to safety reasons. To use these functions you have to log in with your password after the control's prompt. The password is set to 00000000 ex factory.

Supervisor

To change certain system settings, e. g. "Language", "Units" and the settings in the "Service" menu, requires expert knowledge. Users of the USER user group do not have access to these parameter. To change these settings, a password of the SUPERVISOR user group is required. The password is set to 87654321 ex factory.

- ▶ Change the password immediately after the first commissioning, see page 70.

Menu overview

A pass word is required to access the option menu . The following main entries are contained therein:

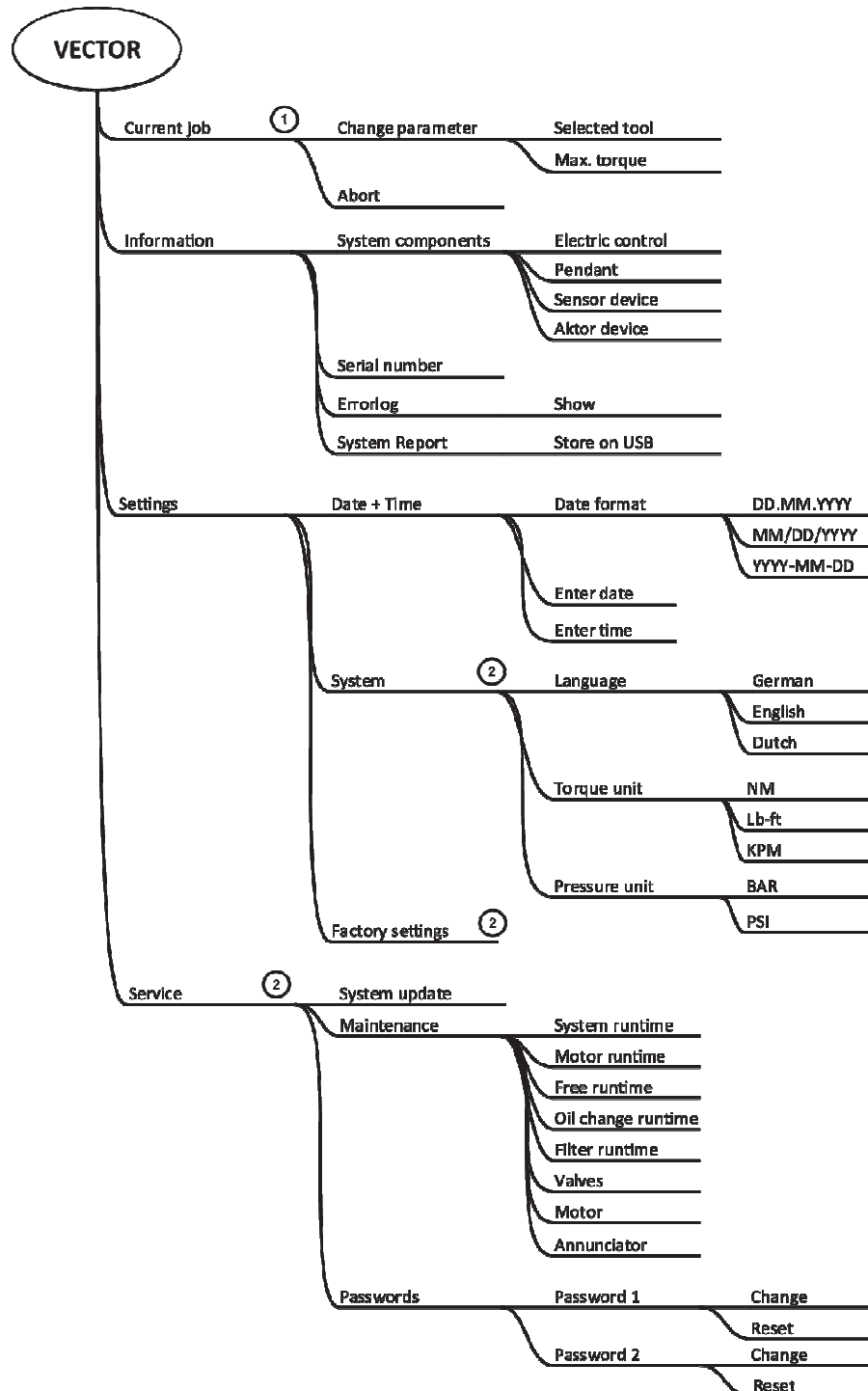



① This menu point appears only if a job has started.

② This menu point is only available after a foreman has entered his password.

Enter password

Upon the password prompt proceed as follows:

The value to be entered is shown in red.

- ▶ With the  or  select the respective value.
- ▶ Confirm using the green button.

The next value to be entered is shown in red.

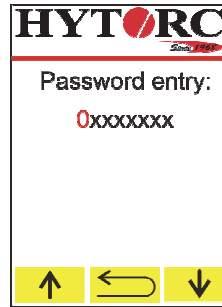

- ▶ Enter the remaining values as described before.

If you have correctly entered your password, you have access to further functions and settings.



Opening a menu

To open a menu, proceed as follows:

- ▶ With the  or , select the respective entry.
- ▶ Press the green button.

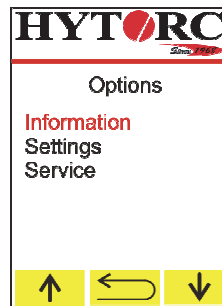

The available content of the menu is shown.

- ▶ To return to a higher menu level press the .
- ▶ To open available sub-menus, proceed as previously described.

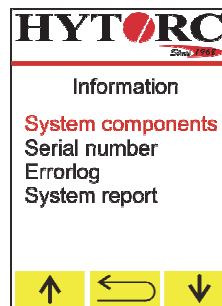

Show information

Show information about system components

To display information about the system components, proceed as follows:

- ▶ In the "Information" menu, open the "System component" sub-menu.

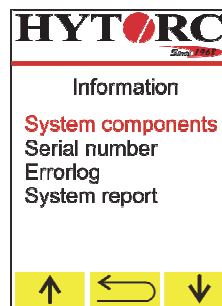



In the "System component" sub-menu, the following information can be found:

- "Electrical control":
 - Firmware Version
 - μ -ID
 - Project coding
 - Hardware ID
 - Revision ID

- "Remote control":
 - Firmware Version
 - μ -ID
 - Project coding
 - Hardware ID
 - Revision ID
 - Language module
 - Font module
 - Image module

- "Sensor-Device":
 - Firmware Version
 - μ -ID
 - Project coding
 - Hardware ID
 - Revisions ID

- "Actor-Device":
 - Firmware Version
 - μ -ID
 - Project coding
 - Hardware ID
 - Revisions ID

▶ With the  or , select the respective entry.

▶ Press the green button.

The first available information is shown.

▶ With  and  you can scroll through the available information.

▶ With  you return to the sub-menu of the system components.

Display serial number

To display the serial number, proceed as follows:

- ▶ In the "Information" menu, open the "Serial number" sub-menu.

The serial number is shown.

- ▶ With  you return back in the "Information" sub-menu.

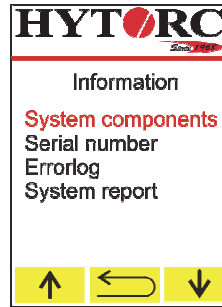



Display error log

To display the error log, proceed as follows:

- ▶ In the "Information" menu open the "Error log" sub-menu.
- ▶ Press the green button.

The first available entry of the error log is shown.

- ▶ With  and , you can scroll through the available information.
- ▶ With  you return to the "Information" sub-menu.

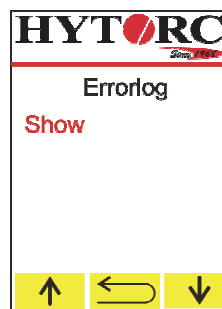

Save system report

In the event of a fault, you can create a system report and send it to the manufacturer. To save the system report to a USB stick, proceed as follows:

- ▶ From the "Information" menu, go to the "System Report" submenu.
- ▶ Press the green button.

The "Save system report to USB" entry is displayed.

- ▶ Plug the USB stick into the USB port
- ▶ Press the green button.

The system report is saved onto the USB stick.

- ▶ With  you return to the "Information" sub-menu.

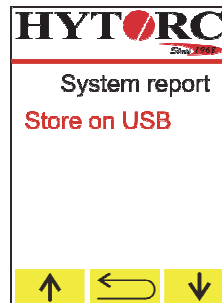

Show information about maintenance

To display information about the maintenance, proceed as follows:

- ▶ In the "Service" menu open the "Maintenance" sub-menu.

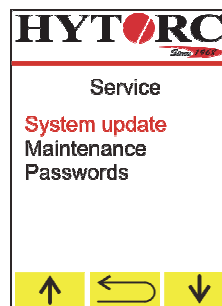

In the "Maintenance" sub-menu the following information can be found:

- System runtime
- Motor runtime
- Free runtime
- Oil change time
- Filter runtime
- Valves
- Motor
- Signal transmitter.

▶ With  or  select "System runtime".

The entry is highlighted in red.

▶ Press the green button.

The up to now elapsed system runtime (switch-on duration of control) is shown in hours.

▶ Press the , to reach selection in the "maintenance" menu.

▶ With  or  select "Motor runtime".

The entry is highlighted in red.

▶ Press the green button.

The up to now elapsed motor runtime is shown in hours.

▶ Press the , to reach selection in the "Maintenance" menu.

▶ With  or  select "Free runtime".

The entry is highlighted in red.

▶ Press the green button.

The so far passed free runtime (not yet supported) is shown in hours.

▶ To delete the value, press .

▶ Press the , to reach selection in the "Maintenance" menu.

▶ With  or  select "Oil change runtime".

The entry is highlighted in red.

▶ Press the green button.

The runtime passed since the last oil change is shown in hours. After 500 operating hours a note in the display will prompt you to perform an oil change.

▶ Delete the value after the oil change.

▶ To delete the value, press .

▶ Press  to reach selection in the "Maintenance" menu.



Operate software

- ▶ With  or  select "Filter runtime".

The entry is highlighted in red.

- ▶ Press the green button.

The runtime passed since the last oil filter change is shown in hours.

- ▶ Delete the value after the oil filter change.
- ▶ To delete the value, press .
- ▶ Press  to reach selection in the "Maintenance" menu.

- ▶ With  or  select "Valves".

The entry is highlighted in red.

- ▶ Press the green button.

The number of the solenoid valves switching operations is displayed.

- ▶ Press  to reach selection in the "Maintenance" menu.

- ▶ With  or  select "Motor".

The entry is highlighted in red.

- ▶ Press the green button.

The number of the motors switching operations is displayed.

- ▶ Press  to reach selection in the "Maintenance" menu.

- ▶ With  or  select "Signal transmitter".

The entry is highlighted in red.

- ▶ Press the green button.

The number of switching operations of the connected signal transmitter is displayed.

- ▶ Press  to reach selection in the "Maintenance" menu.

Change settings

The setting menu contains the following sub-menus:

- Date and time
- System (user rights of supervisor required)
- Factory settings (supervisor user rights required)

Setting the date format

▶ In the "Setting" menu open the "Date and Time" sub-menu.

▶ With  or  select "Date format".

The entry is highlighted in red.

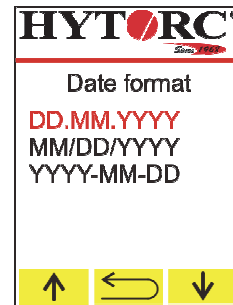

▶ Press the green button.



In delivery state the setting is DD.MM.YYYY.

You are able to set the following date formats:

- DD.MM.YYYY
- MM/DD/YYYY
- YYYY-MM-DD

▶ With the  or , select the respective entry.

▶ Press the green button.

The date format is adopted.

▶ With  you return back in the "Setting" sub-menu.

Setting the date

▶ In the "Setting" menu open the "Date and Time" sub-menu.

▶ With **↑** or **↓** select "Date input".

The entry is highlighted in red.

▶ Press the green button.

You can set the day, month and year. The changeable entry is displayed in red.

▶ To set the value for the day, press the corresponding button repeatedly.

▶ To decrease the value, select **↓**.

▶ To increase the value, select **↑**.

▶ To switch to the previous entry, select **←**.

▶ Confirm your settings using the green button.

The month is shown in red and can be adjusted.

▶ Set the month and then the year as previously described.

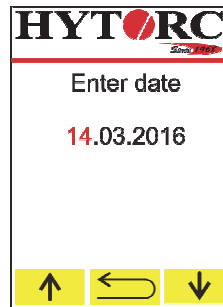

Setting the time

▶ In the "Setting" menu open the "Date and Time" sub-menu.

▶ With **↑** or **↓** select "Time input".

The entry is highlighted in red.

▶ Press the green button.

You can set the hours, minutes and seconds. The changeable entry is displayed in red.

▶ To set the value for the hour, press the corresponding button repeatedly.

▶ To decrease the value, select **↓**.

▶ To increase the value, select **↑**.

▶ To switch to the previous entry, select **←**.

▶ Confirm your settings using the green button.

The minutes are shown in red and can be adjusted.

▶ Set the minutes and then the seconds as previously described.

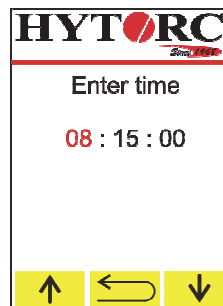

Setting the language

- ▶ In the "System" menu open the "Language" sub-menu.

You can now set the language to German, English or Dutch. Upon request, other languages can be provided as update.

- ▶ With the  or  select the respective language.

The entry is highlighted in red.

- ▶ Press the green button.

The language is set.

- ▶ With  you return to the "System" sub-menu.



Setting the torque unit

- ▶ In the "System" menu open the "Torque unit" sub-menu.

You can set it to Nm, lb-ft or Kpm.

- ▶ With the  or  select the respective unit.

The entry is highlighted in red.

- ▶ Press the green button.

The unit is set.

- ▶ With , you return to the "System" sub-menu.

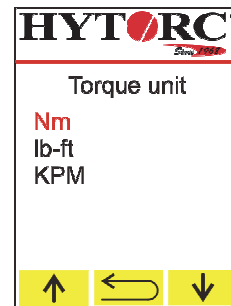

Set pressure unit

- ▶ In the "System" menu open the "Pressure unit" sub-menu.

You can now set BAR or PSI.

- ▶ With the  or  select the respective unit.

The entry is highlighted in red.

- ▶ Press the green button.



The unit is set.

- ▶ With , you return to the "System" sub-menu.





Reset to factory settings

① The user rights of a supervisor are needed to reset to factory settings. Resetting to factory settings puts the control in the state prior to initial commissioning.

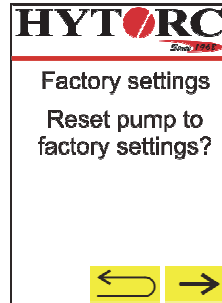
- ▶ In the "Settings" menu, open the "Factory settings" sub-menu.
- ▶ Press .
- ▶ To switch to the previous entry, select .



- ▶ To abort the process, press .
- ▶ To reset the control to factory settings, press .

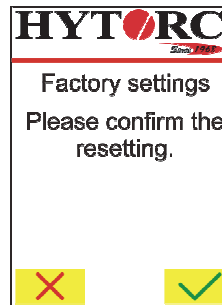

Operating the unit

⚠ DANGER	
	<p>Explosion hazard when operating the unit in explosion-hazardous areas</p> <p>Operating the unit in explosion-hazardous areas can lead to serious injury or death.</p> <ul style="list-style-type: none">▶ Operate the unit only in areas where there is no explosive atmosphere (check first for safe levels).

To operate the unit, proceed as follows:

- ▶ Make sure that the unit stands on a dry, level, solid and stable base.

Changing tools

⚠ WARNING	
	<p> Serious injury or death due to hydraulic oil under high pressure spouting.</p> <ul style="list-style-type: none">▶ Always switch off the unit with the toggle switch on the electric control.▶ Ensure the unit is de-pressurized.

- ▶ Always switch off the unit with the toggle switch on the electric control.
- ▶ Loosen the nut (B).
- ▶ Pull the female connector (B) from the male connector (14) of the unit.
- ▶ Loosen the nut (13).
- ▶ Pull the male connector (A) from the female connector (13) of the unit.

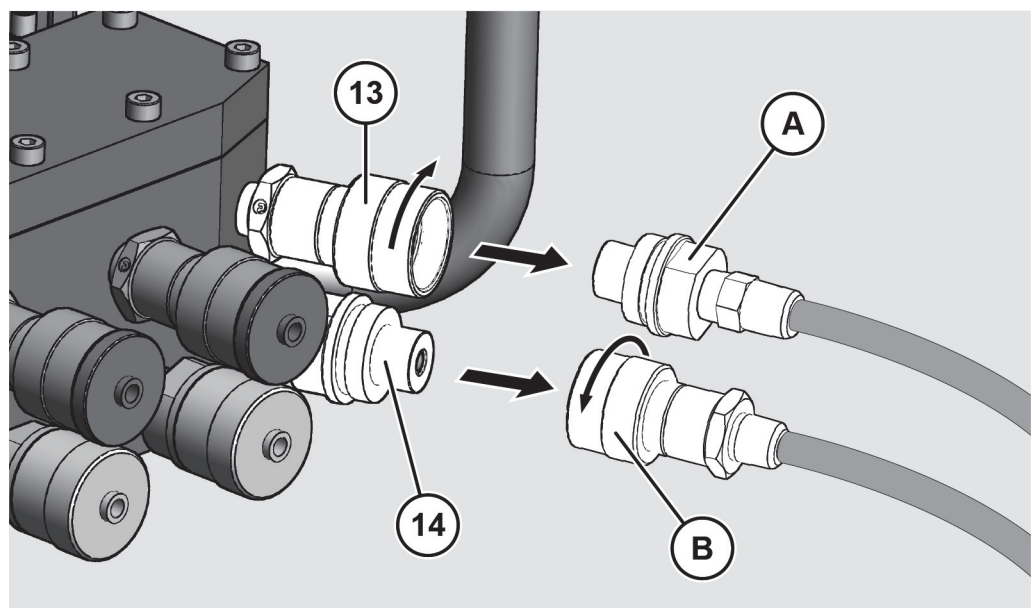

If you want to install the new tool at the same couplings, proceed as follows:

- ▶ Plug the male connector on the hydraulic hose of the tool on the female connection of the unit.
- ▶ Screw the connection with the union nut hand-tight.
- ▶ Plug the female connection on the hydraulic hose of the tool on the male connection of the unit.
- ▶ Screw the connection with the union nut hand-tight.

If you want to install the new tool at another coupling, proceed as follows:

ATTENTION!

Damage and contamination of unprotected couplings.
The couplings can become leaky and hydraulic oil will escape.

- ▶ Protect the couplings when not in use with the protective caps and plugs against damage and contamination.

If you have pulled a tool from the connection, you have to close the connection with a cap and protection plug to prevent damage. Proceed as follows:

- ▶ Screw the safety plug (A) clockwise on the corresponding connection (13).
- ▶ Screw the safety cap (B) clockwise on the corresponding connection (14).

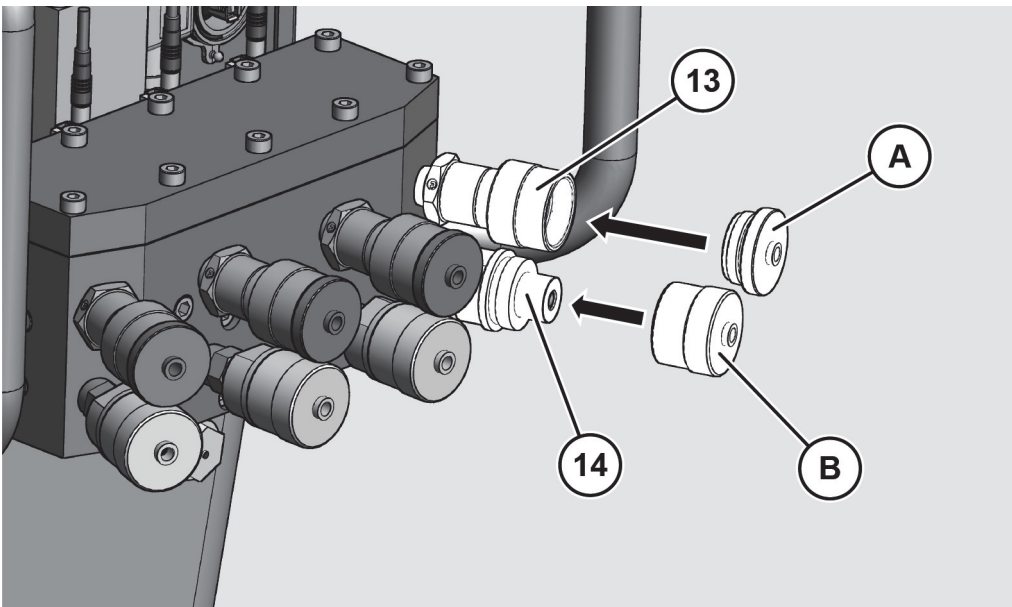

Before you can connect a tool, you must remove the protective cap and the protective plug of two stacked couplings. Proceed as follows:

- ▶ Screw the protective plug (A) counterclockwise from the corresponding connection (13).
- ▶ Screw the safety cap (B) counterclockwise from the corresponding connection (14).

The cap and the protective plugs are permanently connected to the corresponding coupling.

You can now connect a tool.

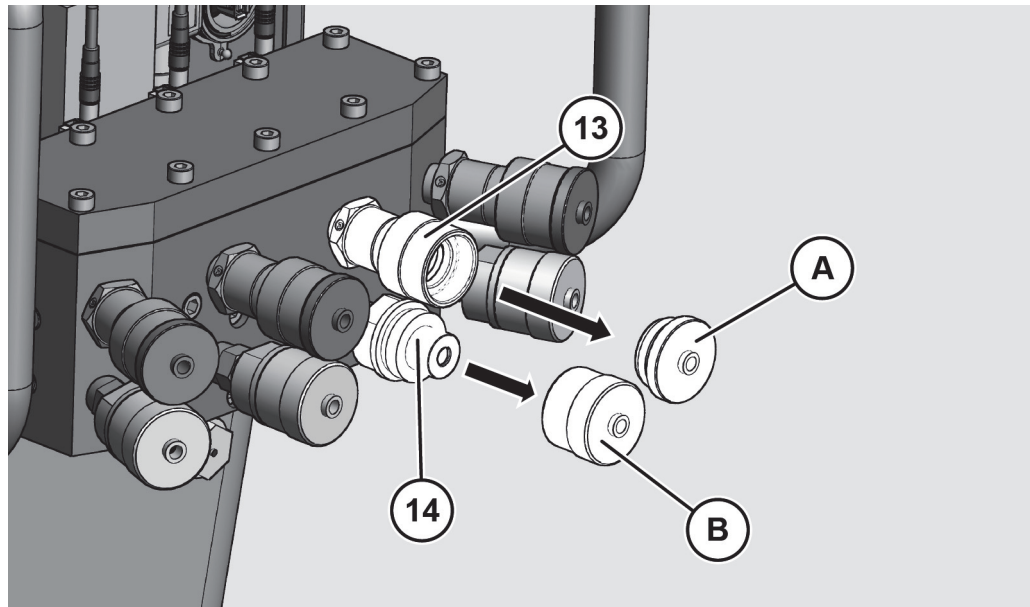

- ▶ Plug the female connection on the hydraulic hose of the tool on the male connection of the unit.
- ▶ Screw the connection with the union nut hand-tight.
- ▶ Plug the male connector on the hydraulic hose of the tool on the female connection of the unit.
- ▶ Screw the connection with the union nut hand-tight.

Perform system measurement

After you have completed the settings for the screwing tool, a system measurement is required. Here, the control checks the current state of the unit.

- ▶ Place the connected screwing tools on the ground.
- ▶ Press the green button and hold it down.



The pump builds up pressure and starts the system measurement.

- ▶ Keep the green button pressed.
- ▶ In a dangerous situation, press **Stop**.

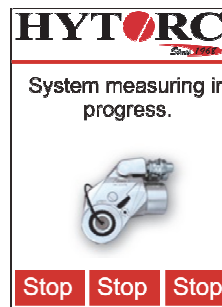

- ▶ After the system measurement is completed successful, release the green button.
- ▶ In a dangerous situation, press **Stop**.



Place the tool or the tools on the respective screw connection.

- ▶ To switch off the motor press **⏻**.
- ▶ To perform screwing in manual mode, see page 68.
- ▶ To perform screwing in automatic mode, see page 69.





Change current order

To change the information of a current order (screwing application), proceed as follows:

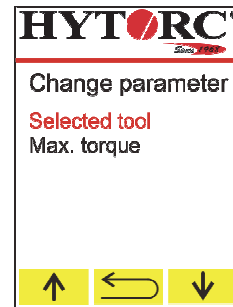
- ▶ In the "Option" menu open the "Current order" sub-menu.
- ▶ Select "Change parameter".
- ▶ To set the parameter for the screwing tool, select "Selected tool".



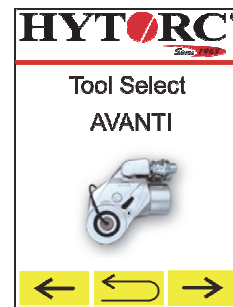

To set the appropriate screwing tool for screwdriving, proceed as follows:

- ▶ To display the next available screwing tool, choose .
- ▶ To display the previous screwing tool, choose .
- ▶ To open return to the "Change parameter" menu, select .
- ▶ To accept the displayed screwing tool, confirm the selection with the green button.



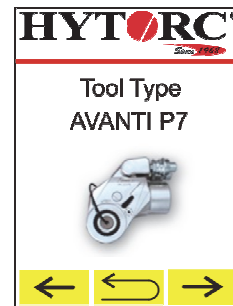

To set the appropriate size of the screwing tool for screwdriving, proceed as follows:

- ▶ To show the next size of the screwing tool, select .
- ▶ To show the previous size of the screwing tool, select .
- ▶ To switch to the selection of the screwing tool, select .
- ▶ To accept the displayed size of the screwing tool, confirm the selection with the green button.



To set the appropriate torque value for screwdriving, proceed as follows:

- ▶ To set the value in smaller increments, press the corresponding button repeatedly.
- ▶ To change the value continuously press and hold the respective button.
- ▶ To decrease the torque value, select .
- ▶ To increase the torque value, select .
- ▶ To switch to the selection of the screwing tool, select .
- ▶ To accept the displayed torque values, confirm the selection with the green button.

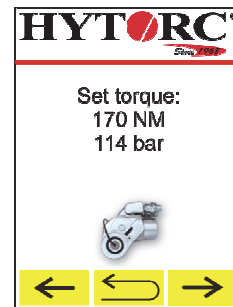



Change the maximum torque of the current order

To change the information of a current order (screwing application), proceed as follows:

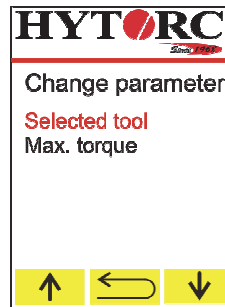
- ▶ In the "Option" menu open the "Current order" sub-menu.
- ▶ Select "Change parameter".
- ▶ To set the maximum torque for the screwing tool, select "Max. Torque".



To set the appropriate torque value for screwdriving, proceed as follows:

- ▶ To set the value in smaller increments, press the corresponding button repeatedly.
- ▶ To change the value continuously press and hold the respective button.
- ▶ To decrease the torque value, select .
- ▶ To increase the torque value, select .
- ▶ To switch to the selection of the screwing tool, select .
- ▶ To accept the displayed torque values, confirm the selection with the green button.



Perform screwing process manually

To perform screwing manually, proceed as follows:

- ▶ Make sure that the mode is "Manual set".
- ▶ Ensure that "System measuring" was successfully completed.
- ▶ Make sure that the screwing tools are attached to the screw connections.
- ▶ In a dangerous situation, press .
- ▶ Press the green button and hold it down.

The pump builds up pressure, the current torque is displayed, the tool tightens the screw connection.

- ▶ When the set torque is shown in the display and the screwing tool no longer moves, release the green button.

The tool moves to its initial position.

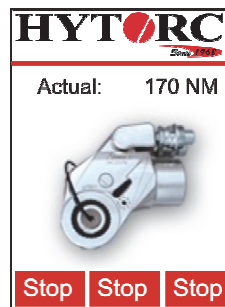

- ▶ Repeat the process until the screw connection cannot be tightened further.

The screw connection has been tightened with the set torque.

- ▶ To switch off the pump, press .
- ▶ In a dangerous situation, press **Stop**.
- ▶ Attach the screwing tool on the next to be tightened fittings.

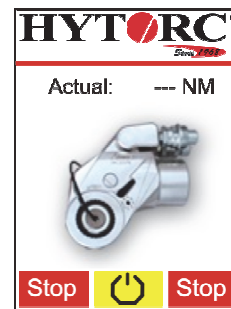

Perform screwing process automatically

The screw connections are initially pre-tightened, if at least two screwing tools are connected. This is done with a smaller torque than the set torque.

The following states of the screw connection are shown in the display during the screwing process:

- Screwing is being performed (in process).
- The screw connection is pre-tightened, the tightening with the set torque follows directly at the connection.
- The control checks the tightened screw connections (inspection).

To perform screwing automatically, proceed as follows:

- ▶ Ensure that System measuring was successfully completed.
- ▶ Make sure that the screwing tools were attached to the screw connections.
- ▶ In a dangerous situation, press **Stop**.
- ▶ Press the green button and keep it pressed during the complete screwing process.

The pump builds up pressure, screwing is performed, the current state of each screw connection is shown in the display.

In the display illustration at the side, already three screw connections are checked for correct torque.

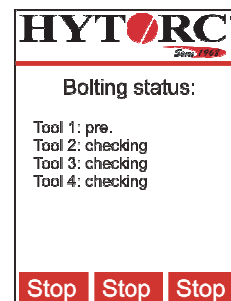
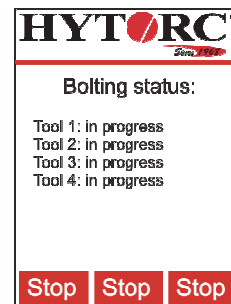

Checking the screw connection has been successfully completed.

- ▶ Release the green button.

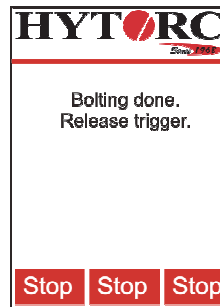

The green button is no longer pressed. The fully automatic screwing process is completed.



- ▶ Press  to switch off the pump.
- ▶ Attach the screwing tool on the next to be tightened fittings.



Change password

 The user rights of a supervisor are needed to change or reset a password.



To change the password, proceed as follows:

- ▶ In the "Service" menu open the "Password" sub-menu.
- ▶ With  or , select the password to be changed.

The password to be changed is shown in red.

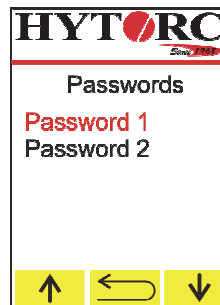
With  you return to the "Service" menu.



- ▶ Confirm using the green button.
- ▶ With  or , select the password you would like to change or reset.



During "Change" you are overwriting the present password.

With "Reset", the password from the delivery state is activated again.

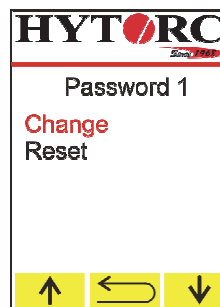
With  you return to the "Passwords" sub-menu.





To reset the password, proceed as follows:

- ▶ Select "Reset".
- ▶ Confirm using the green button.
- ▶ To reset the password press .
- ▶ To abort the process press .



To enter a new password, proceed as follows:

- ▶ Select "Change".
 - ▶ Confirm using the green button.
- The value to be entered is shown in red.
- ▶ With the  or  select the respective value.
 - ▶ Confirm using the green button.
- The next value to be entered is shown in red.
- ▶ Enter the remaining values as described before.

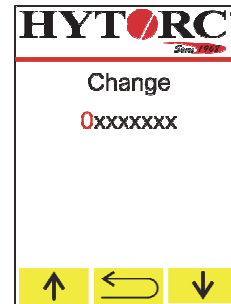

The new password was saved.

With  you return to the sub-menu of the corresponding password.

Emergency stop has been pressed

After pressing , an emergency stop is performed. The emergency stop does the following:

- The pump is switched off.
- The green button has no function.
- The buttons for controlling the display contents are not functional.

The screen shown is displayed for about five seconds in the display. After these five seconds have elapsed, the buttons are functional again.



To prepare the screwing tool ready for use, proceed as follows:

- ▶ Make sure that the cause for triggering the emergency stop function has been remedied.
- ▶ Press  and you hold the button.
- ▶ Press the green button.



The tool is ready for use again.

- ▶ Release the pressed button.

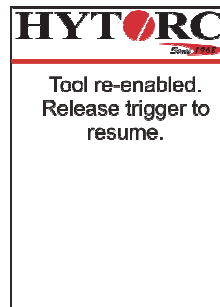

To continue the interrupted screwing process, proceed as follows:

- ▶ Press the green button and hold it down.

To perform a manual screwing process, see page 68.

To perform an automatic screwing process, see page 69.

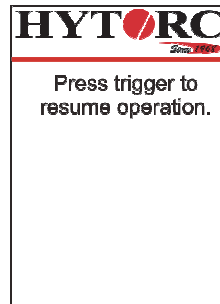

Load tool data (tool files)

To keep the existing tool data (tool Files) in control of the unit up to date, you can update as necessary.

You will need:

- USB stick with FAT formatting
- PC
- HY-VECTOR unit
- Tool Files.

 Current tool files can be obtained from HYTORC.

To transfer the tool files in the control of the unit, proceed as follows:

- ▶ Connect a USB flash drive with FAT formatting to a PC on which the tool files are stored.
- ▶ In the root directory of the USB stick, create a folder and name it "Tool Files".
- ▶ Copy all tool files that you want to transfer to the "Tool Files" folder.

CAUTION!

- Malfunctioning due to changed file names.
The control of the unit cannot handle these tool files.
- ▶ Do not change the file names of tool files.

- ▶ Remove the USB stick from the PC.
 - ▶ Connect the USB stick to the USB connection (28) of your unit.
- ⓘ In rare cases, it may happen that the USB stick is not recognized by the electric control. In such case, copy the data to a different USB stick and try again.

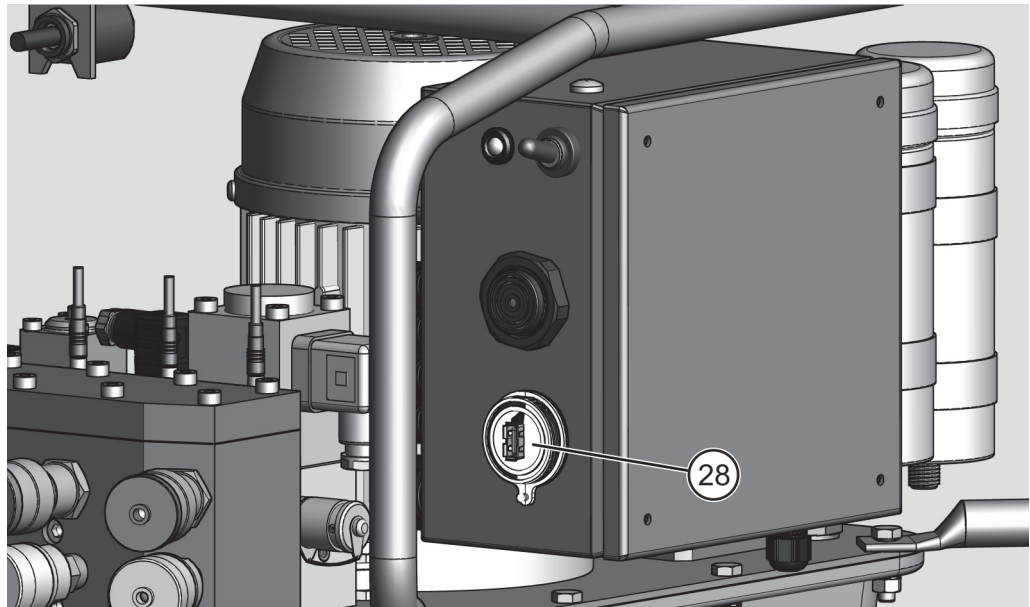

- ▶ Connect the power plug of the unit only to a suitable grounded electrical outlet.
- ▶ Using the toggle switch, switch the unit on.

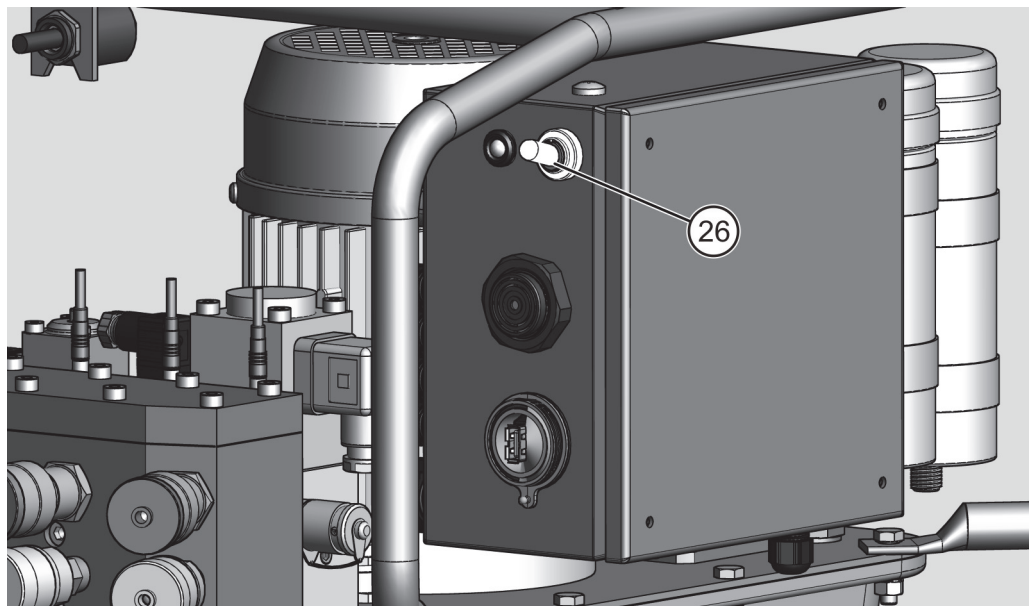

Operating the unit

The control of the unit starts up and checks the content of the "Tool Files" on the USB stick.

The LED flashes green.

All new tool data (tool files) are added in the control.

Outdated versions (tool files) are replaced by any available current versions.

After updating the tool data (tool files), the unit performs a synchronization with the connected components e.g. the remote control.

When the synchronization is completed, the LED is green and you will hear a short beep.

In the display of the remote control, the unit's operational readiness is displayed.

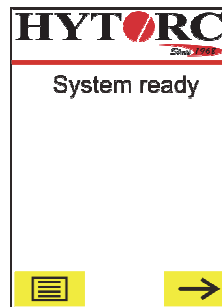
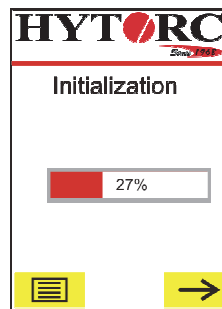

Firmware Update

Prepare update

To keep the existing software in the control of the unit up to date, you can update as necessary.

You will need:

- USB stick with FAT formatting
- PC
- HY-VECTOR unit
- Current software

 Current software can be obtained from HYTORC.

During updating the following can be updated:

- Firmware of the electric control
- Firmware of the connected systems e. g. remote control, pressure sensors
- Tool data (tool files); the tool data can be updated separately, see page 72.

To prepare for an update, proceed as follows:

- ▶ Open the appropriate ZIP archive for the update with Windows Explorer or an archiving tool (e.g.: Winrar, 7zip, ...)
- ▶ Select all files and copy them to the root directory of the USB stick.

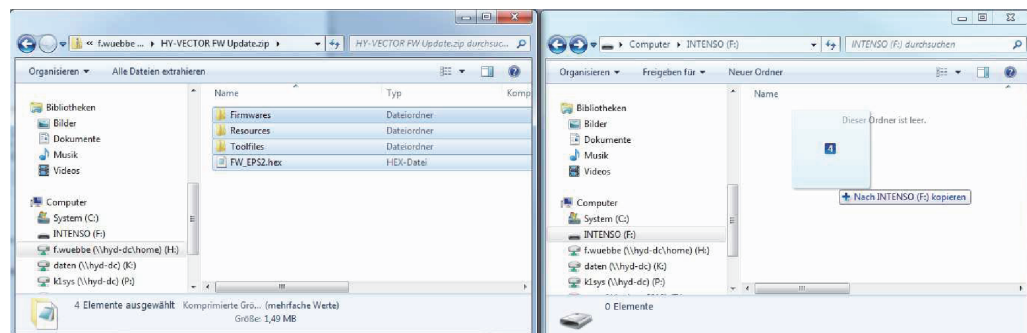

- ▶ Ensure that all files are on the USB stick and have the same folder structure as the ZIP archive.

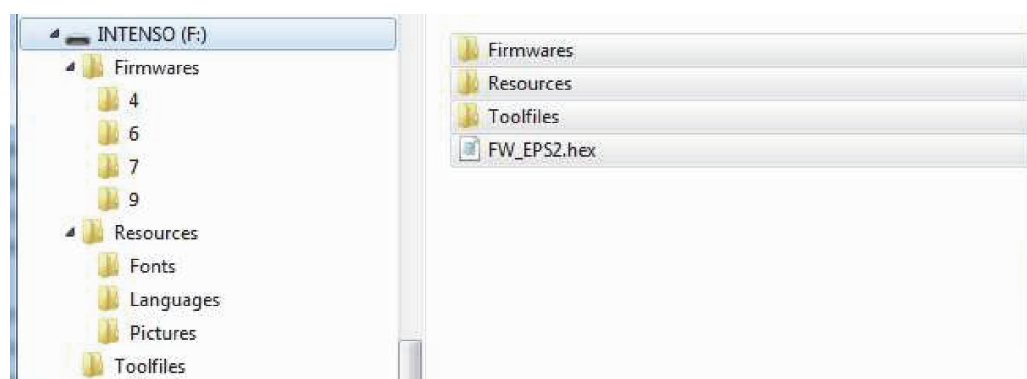

The USB drive is now ready for use on the unit.

Perform update

To perform an update, proceed as follows:

- ▶ Connect the USB stick with the new Firmware to the USB connection (28) of your unit.

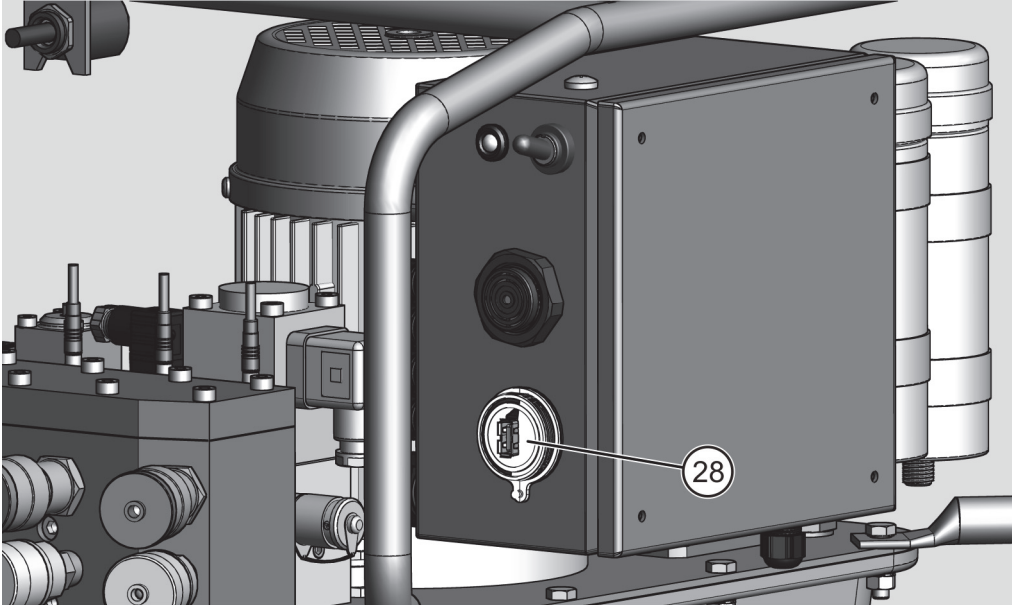

- ▶ Connect the power plug of the unit with the mains power supply.
- ▶ Using the toggle switch (26), switch on the unit.

Once the unit is switched on, it begins with the import of the new firmware from the USB stick.

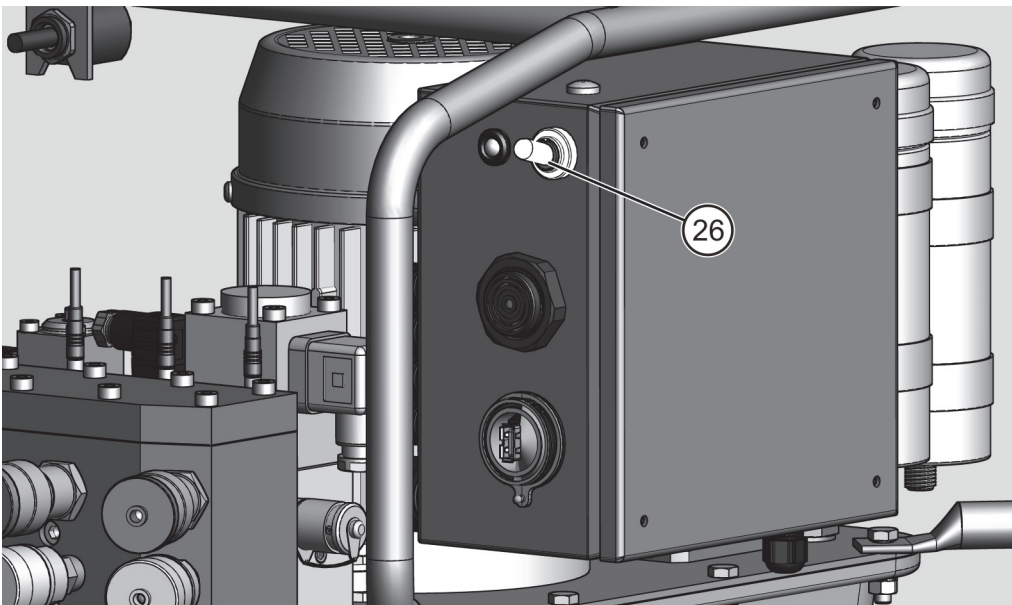

All new files are added in the control. Outdated versions (tool files) are replaced by any available current versions.

After updating the software, the unit performs a synchronization with the connected components, e.g. the remote control.

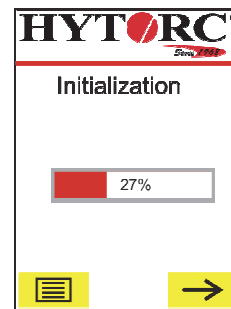

When the synchronization is completed, the LED is green and you will hear a short beep.

In the display of the remote control, the unit's operational readiness is displayed.

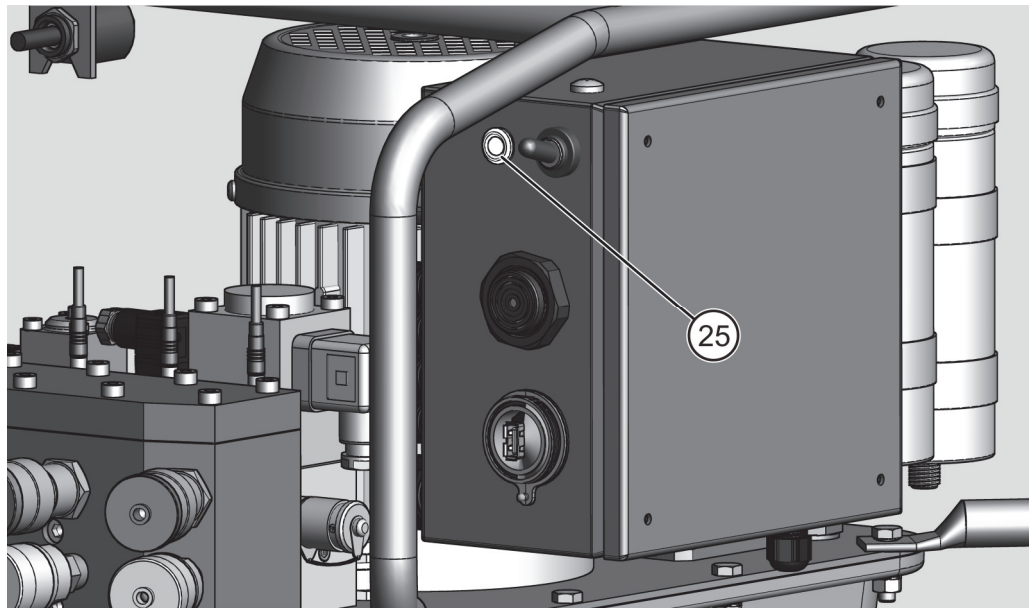

i In rare cases, it may happen that the USB stick is not recognized by the electric control. In such case, copy the data to a different USB stick and try again.

► Pull the USB stick from the unit.

After use

⚠ WARNING



Serious injury or death due to hydraulic oil under high pressure spouting.

- ▶ Always switch off the unit with the toggle switch on the electric control.
- ▶ Ensure the unit is de-pressurized.

- ▶ Always switch off the unit with the toggle switch on the electric control.
- ▶ Unplug the power cord from the wall outlet.

To remove the connected screwing tools, proceed as follows:

- ▶ Loosen the nut (B).
- ▶ Pull the female connector (B) from the male connector (14) of the unit.
- ▶ Loosen the nut (13).
- ▶ Pull the male connector (A) from the female connector (13) of the unit.

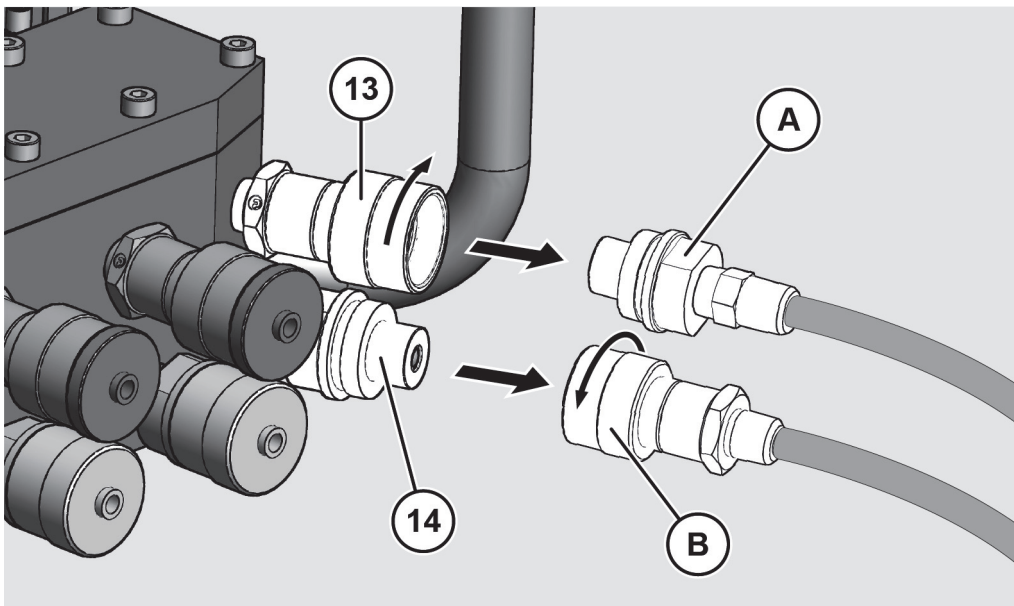

ATTENTION!

Damage and contamination of unprotected couplings. The couplings can become leaky and hydraulic oil will escape.

- ▶ Protect the couplings when not in use with the protective caps and plugs against damage and contamination.

- ▶ Screw the protective caps (B) and plugs (A) on the couplings (13, 14).

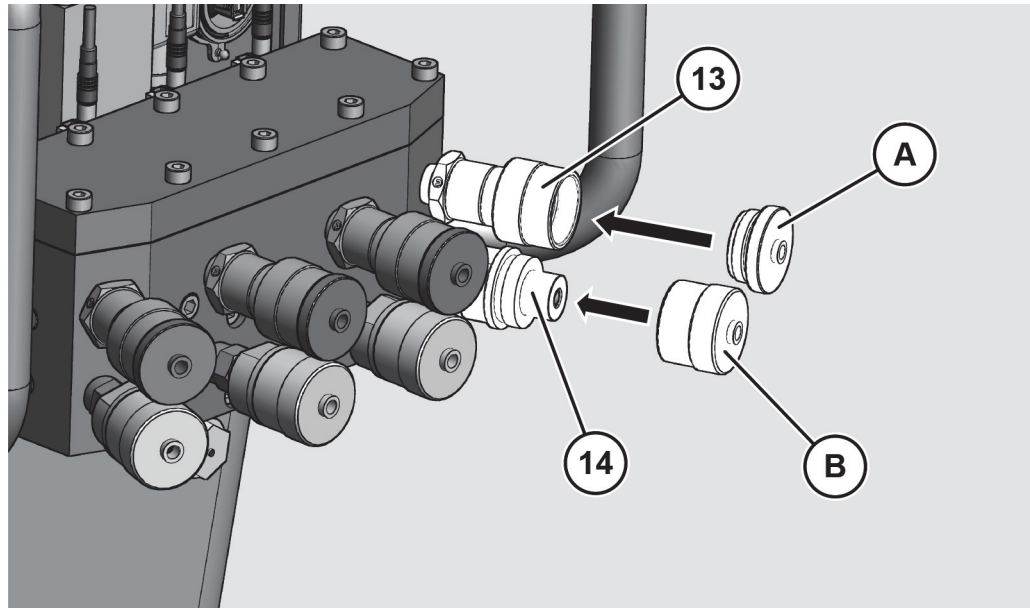

- ▶ You can now store or transport the unit.

Decommissioning the unit

To take the unit out of operation for more than three months, proceed as follows:

- ▶ Switch the toggle switch on the electric control in the upper position.
- ▶ Unplug the power cord from the wall outlet.
- ▶ Remove attached screwing tools, see from page 78.
- ▶ Perform an oil change, see from page 82.

The emptying is described in section "Changing the hydraulic oil" starting from page 82.



- ▶ Dispose of the hydraulic oil according to the rules and regulations applicable on site.
- ▶ Store the unit as described starting on page 37.

Servicing the unit

Maintenance schedule

Interval	Component	Action
Prior to every operation	Electrical connection lines	<ul style="list-style-type: none"> ▶ Check electrical connection cables for visible damage, twists and kinks. ▶ Eliminate twists. ▶ Have defective or kinked electrical leads replaced by qualified personnel.
	Hydraulic hoses	<ul style="list-style-type: none"> ▶ Check the hydraulic hoses for visible damage, twists and kinks. ▶ Eliminate twists. ▶ Have defective or kinked hydraulic hoses replaced by qualified personnel.
Before each coupling	Couplings	<ul style="list-style-type: none"> ▶ Clean the couplings with a dry cloth.
As necessary	Unit	<ul style="list-style-type: none"> ▶ Clean the unit with a dry cloth.
	Oil filter 3 µm	<ul style="list-style-type: none"> ▶ Replace the oil filter, see page 85.
Every 500 hours of operation	Oil container	<ul style="list-style-type: none"> ▶ Change the hydraulic oil, see page 82.
	Oil filter 20 µm	<ul style="list-style-type: none"> ▶ Replace the oil filter, see page 85.

Changing the hydraulic oil

⚠ WARNING	
	<p>Slipping hazard from leaked oil. Bruising and bone fractures possible.</p> <ul style="list-style-type: none"> ▶ Clean up any leaked oil with a cloth or suitable binding agents. ▶ Wear safety shoes with non-slip soles.
⚠ CAUTION	
	<p>Health hazard from contact with hydraulic oil.</p> <ul style="list-style-type: none"> ▶ Wear nitrile gloves and chemical-resistant protective goggles during work that may include contact with hydraulic oil.
ATTENTION!	
	<p>The use of hydraulic oils that do not meet the manufacturer's recommendation may cause damage to the unit. Warranty claims can become invalid.</p> <ul style="list-style-type: none"> ▶ Only use hydraulic oil recommended by the manufacturer.

① The manufacturer-approved oils can be found starting on page 97.

To change the hydraulic oil, proceed as follows:

- ▶ Switch the toggle switch on the electric control in the upper position.
- ▶ Unplug the power cord from the wall outlet.
- ▶ Remove attached screwing tools from the couplings, see page 78.
- ▶ Place the unit on a load-bearing, solid and flat surface, for you to be able to put a container under the oil drain plug.
- ▶ Place the unit in a manner that it is tilted slightly forward.
- ▶ Allow the unit including hydraulic oil to cool down.
- ▶ Under the oil drain plug, place a container that can hold the amount of oil contained in the unit of up to 8 l (2.1 US.liq.gal).
- ▶ Remove the oil drain plug (8) and the seal (A).

The hydraulic oil flows into the vessel.

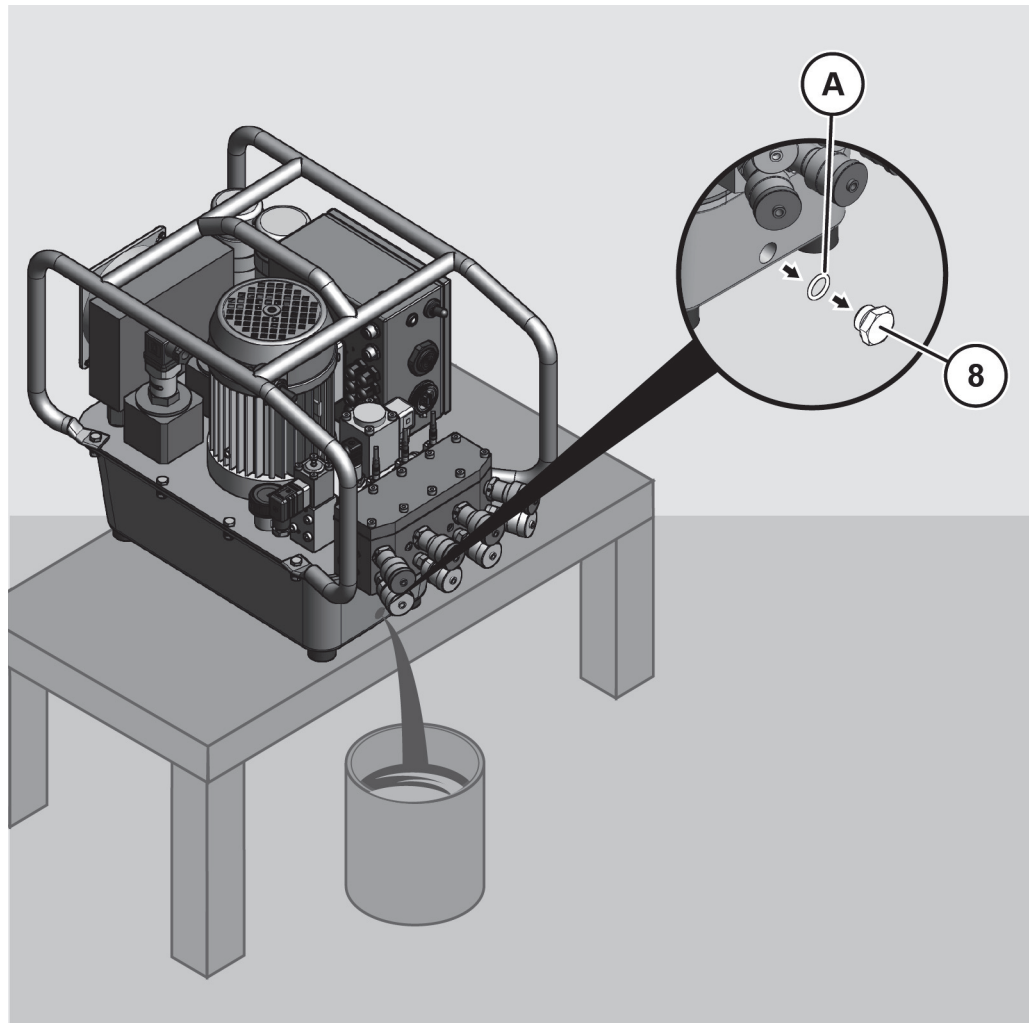

- ▶ Check the seal of the oil drain plug for damage.
- ▶ Replace a damaged seal.
- ▶ Wait until the hydraulic oil has completely drained out of the oil reservoir.
- ▶ Close the oil drain with the oil drain plug.
- ▶ Tighten the oil drain plug with a torque of 20 Nm.

To fill the hydraulic oil in the oil tank of the unit, proceed as follows:

- ▶ Make sure that the unit stands securely on a flat surface.
- ▶ Remove the bleed and ventilation valve (21) of the unit's filling opening.

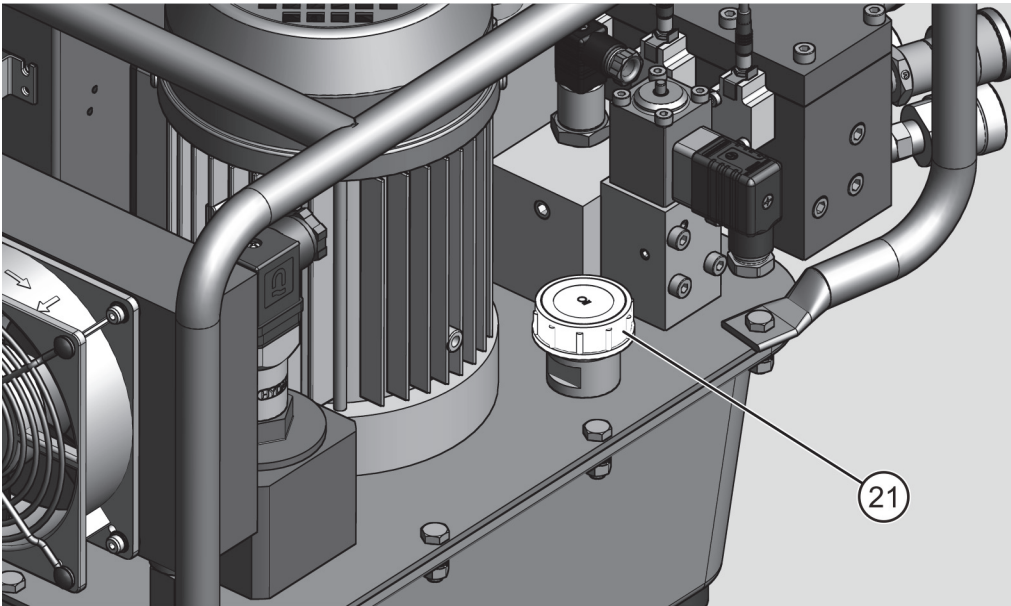

- ▶ Slowly fill fresh hydraulic oil into the oil container until the oil fills the upper sight glass half up.

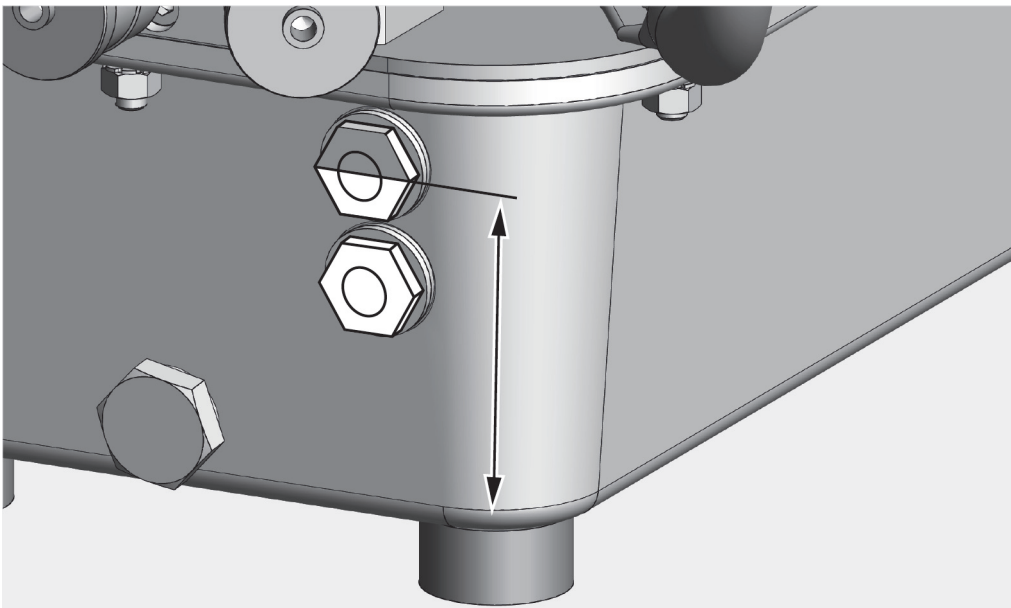

- ▶ Put the bleed and ventilation valve on the filler opening.
- ▶ Tighten the bleed and ventilation valve by hand.
- ▶ Dispose of the drained hydraulic oil according to the environmental regulations applicable on site.
- ▶ Delete the oil change runtime, see page Show information about maintenance.

Replace oil filter

Replace oil filter (3 µm)

To replace the oil filter, proceed as follows:

- ▶ Loosen the center screw.
- ▶ Disconnect the monitoring electric line box (A).

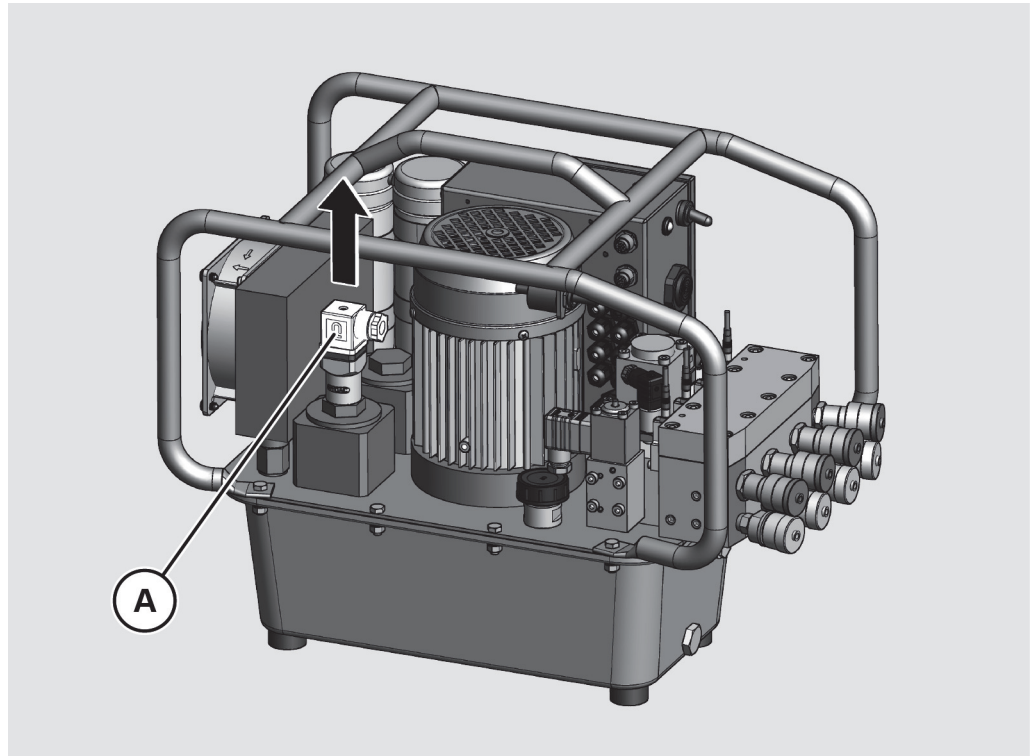

- ▶ Loosen the cover (B) using a SW30 combination wrench.
- ▶ Remove the cover from the filter housing.

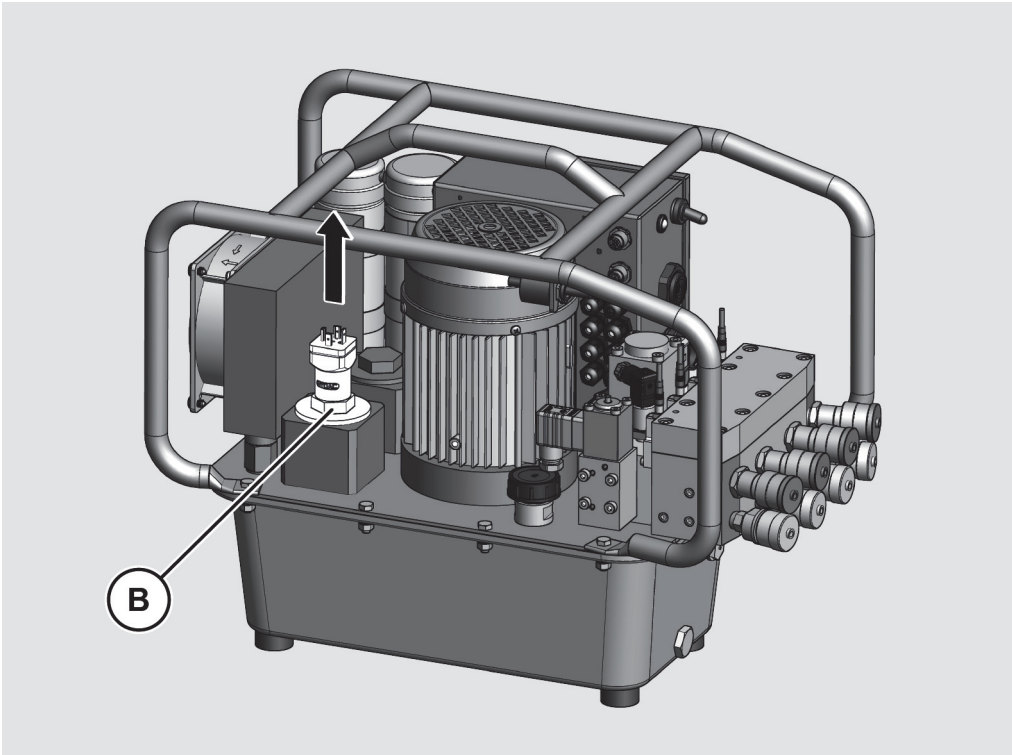



- ▶ Remove the oil filter from the housing.
- ▶ Insert a new oil filter of the same type.
- ▶ Screw on the cover using a SW30 combination wrench.
- ▶ Connect the monitoring electric line box.
- ▶ Tighten the electric line box with the center screw.
- ▶ Dispose of the oil filter in accordance with environmental regulations.

Replace oil filter (20 µm)

To replace the oil filter, proceed as follows:

- ▶ Loosen the cover using a SW30 combination wrench.
- ▶ Remove the cover from the filter housing.
- ▶ Remove the oil filter from the housing.
- ▶ Insert a new filter of the same type.
- ▶ Screw on the cover using a SW30 combination wrench.
- ▶ Dispose of the oil filter in accordance with environmental regulations.
- ▶ Delete the filter runtime, see Chapter Show information about maintenance.

Cleaning the unit

⚠ WARNING	
	<p>Risk of injury from electric shock.</p> <ul style="list-style-type: none"> ▶ Prior to cleaning, pull the power plug from the socket.
⚠ WARNING	
	<p>Slipping hazard from leaked oil. Bruising and bone fractures possible.</p> <ul style="list-style-type: none"> ▶ Clean up any leaked oil with a cloth or suitable binding agents. ▶ Wear safety shoes with non-slip soles.
⚠ CAUTION	
	<p>Health hazard from contact with hydraulic oil.</p> <ul style="list-style-type: none"> ▶ Wear nitrile gloves and chemical-resistant protective goggles during work that may include contact with hydraulic oil.
ATTENTION!	
	<p>Damage or malfunctions caused by water or steam in the unit is possible.</p> <ul style="list-style-type: none"> ▶ Never clean the unit with a pressure washer, cold cleaner or water.

- ▶ Clean the unit with a clean and absorbent cloth.
- ▶ Dispose of the cloth in an environmentally friendly manner.

Remedying faults or malfunctions

Table of faults

Fault	Possible cause	Remedy
The pump does not work.	Electric components are damaged.	▶ Have the electrical components checked and, if necessary, replaced by qualified personnel.
	The power supply is interrupted.	▶ Have the power supply checked or serviced by qualified personnel.
	The remote control is defective.	▶ Have the remote control checked and, if necessary, replaced by qualified personnel.
The engine just hums.	The stator is defective.	▶ Have the motor windings checked by qualified personnel. ▶ Have a defective motor windings repaired by the manufacturer.
	A capacitor is defective.	▶ Have the amperage of the capacitors checked by qualified personnel. ▶ Have a defective capacitor replaced by qualified personnel.
The motor is not working.	The fuse is defective.	▶ Replace the defective fuse, see page 92.

Fault	Possible cause	Remedy
The pressure is less than 70 bar.	The solenoid valve is defective.	<ul style="list-style-type: none"> ▶ Have the solenoid valve checked electrically by qualified personnel. ▶ Have the solenoid valve checked hydraulically by qualified personnel. ▶ Have the defective solenoid valve exchanged by qualified personnel.
	Leakage at the pump flange.	<ul style="list-style-type: none"> ▶ Have the pump flange checked by qualified personnel. ▶ Have a defective pump flange repaired by the manufacturer.
	The suction filter is clogged.	<ul style="list-style-type: none"> ▶ Have the screen filter checked by qualified personnel. ▶ Have the screen filter cleaned by qualified personnel.
	The maximum-pressure valve is leaking.	<ul style="list-style-type: none"> ▶ Have the maximum-pressure valve checked by qualified personnel. ▶ Have a defective maximum-pressure valve exchanged by qualified personnel.
	The piping is leaking.	<ul style="list-style-type: none"> ▶ Have the piping checked by qualified personnel. ▶ Have leaky pipes replaced by qualified personnel. ▶ Have leaky pipe joints sealed by qualified personnel.
The pressure is only 70 bar.	The low-pressure switch-off valve is defective.	<ul style="list-style-type: none"> ▶ Have the low-pressure switch-off valve checked by qualified personnel. ▶ Have a low-pressure switch-off valve exchanged by qualified personnel.
	The piping is leaking.	<ul style="list-style-type: none"> ▶ Have the piping checked by qualified personnel. ▶ Have leaky pipes replaced by qualified personnel. ▶ Have leaky pipe joints sealed by qualified personnel.

Remedying faults or malfunctions

Fault	Possible cause	Remedy
The pressure is only 70 – 80 bar.	The solenoid valve is defective.	<ul style="list-style-type: none"> ▶ Have the solenoid valve checked electrically by qualified personnel. ▶ Have the solenoid valve checked hydraulically by qualified personnel. ▶ Have the defective solenoid valve exchanged by qualified personnel.
	The return pressure valve is leaky.	<ul style="list-style-type: none"> ▶ Have the return pressure valve checked by qualified personnel. ▶ Have a defective return pressure valve exchanged by qualified personnel.
	The piping is leaking.	<ul style="list-style-type: none"> ▶ Have the piping checked by qualified personnel. ▶ Have leaky pipes replaced by qualified personnel. ▶ Have leaky pipe joints sealed by qualified personnel.
The max. pressure of 700 bar is not reached, though no visible leaks are present.	One or more pump elements are defective.	<ul style="list-style-type: none"> ▶ Have the pump elements checked by qualified personnel. ▶ Have the defective pump elements replaced by qualified personnel.
	The piping is leaking.	<ul style="list-style-type: none"> ▶ Have the piping checked by qualified personnel. ▶ Have leaky pipes replaced by qualified personnel. ▶ Have leaky pipe joints sealed by qualified personnel.

Fault	Possible cause	Remedy
The motor switches off.	The motor temperature is too high.	<ul style="list-style-type: none"> ▶ Wait for about 10 minutes and switch the unit on. ▶ If the motor again switches off, have the motor checked by qualified personnel.
The display in the remote varies greatly by about 700 bar.	The non-return valve is defective.	<ul style="list-style-type: none"> ▶ Have a defective non-return valve exchanged by qualified personnel.
Oil mist and oil vapor is forming	The unit is overheating.	<ul style="list-style-type: none"> ▶ Wear breathing protection if ventilation is insufficient. ▶ Wear chemical-resistant safety goggles. ▶ Make sure there is sufficient ventilation. ▶ Switch the unit off. ▶ Have the unit checked by qualified personnel.
	The piping is leaking.	<ul style="list-style-type: none"> ▶ Have the piping checked by qualified personnel. ▶ Have leaky pipes replaced by qualified personnel. ▶ Have leaky pipe joints sealed by qualified personnel.

Replacing fuses

⚠ WARNING



Risk of injury from electric shock caused by inexpert work on the electrical equipment.

- ▶ Disconnect the mains plug from the socket.
- ▶ Have work on electrical equipment carried out only by specialist personnel who are qualified for these tasks.

Prepare for fuse replacement

To prepare to replace a defective fuse, proceed as follows:

- ▶ Unplug the power cord from the wall outlet.
- ▶ Put the unit on stable ground.
- ▶ Use a PZ2 Phillips head screwdriver to remove the screws (A).
- ▶ Remove the cover (B) from the electric control.

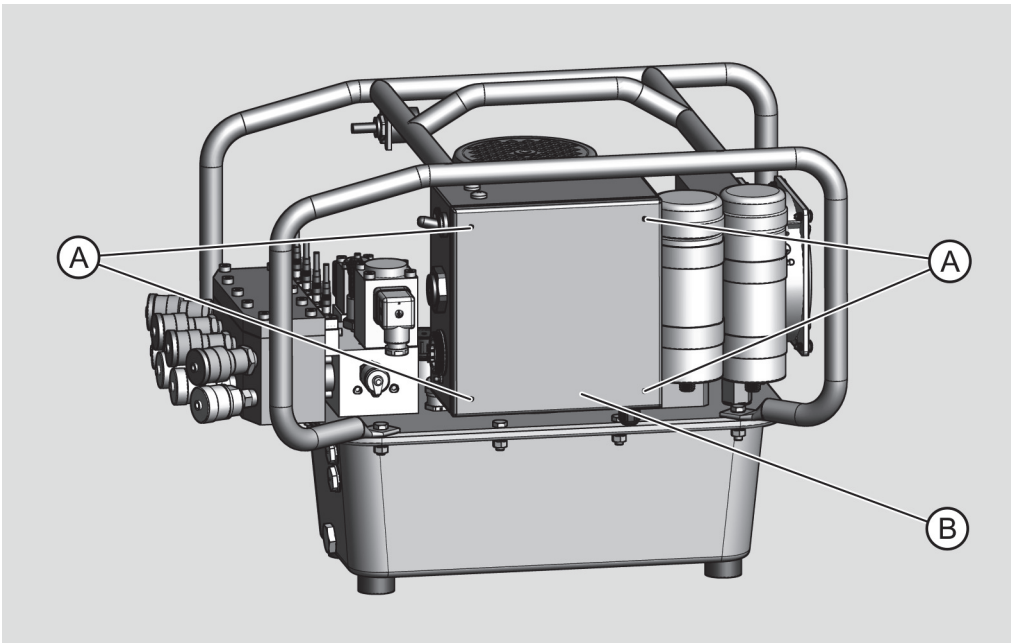

Replace 115 V/230 V fuse

- ▶ Remove fuse F1.
- ▶ Check the condition of the fuses with a multimeter.
- ▶ If the fuse is defective, replace it.
- ▶ Make sure that the new fuse is of the same type and capacity as the fuse to be replaced.

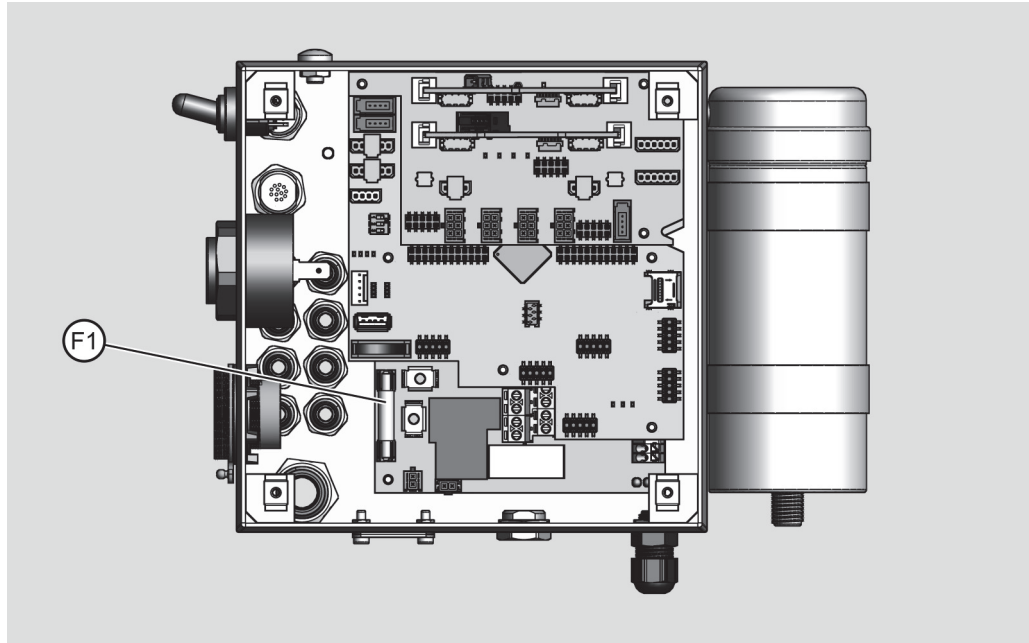

- ▶ Attach the cover with the screws on the electrical control.

Replace 400 V fuse

- ▶ Remove fuses F1, F2 and F3.
- ▶ Check the condition of the fuses with a multimeter.
- ▶ If one or several fuses are defective, replace them.
- ▶ Make sure that the new fuses are of the same type and capacity as the fuses to be replaced.

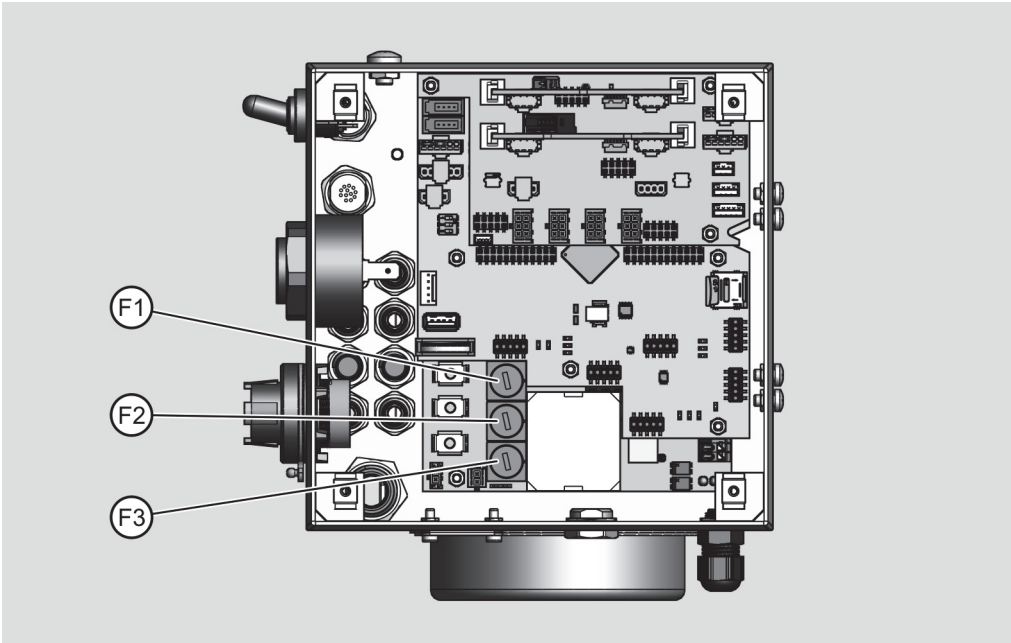



- ▶ Attach the cover with the screws on the electrical control.

Disposal

In the USA

Observe and follow the regulations for disposal. If in doubt, please consult your municipal or local authority.

⚠ WARNING	
	<p>Risk of poisoning from hydraulic oil Hydraulic oil can contaminate ground water and soil.</p> <p>▶ Always dispose of hydraulic oil in an environmentally friendly manner using a specialist firm.</p>
⚠ CAUTION	
	<p>Health hazard from contact with hydraulic oil.</p> <p>▶ Wear nitrile gloves and chemical-resistant protective goggles during work that may include contact with hydraulic oil.</p>

- ▶ Dispose of hydraulic oil in an environmentally friendly manner using a specialist firm.

Replaced wear parts and defective components consist of e. g. the following materials:



- steel
- rubber
- plastic
- copper

⚠ WARNING	
	<p>Risk of poisoning from hydraulic oil Hydraulic oil can contaminate ground water and soil.</p> <p>▶ Use a cloth to remove hydraulic oil from parts to be disposed of.</p> <p>▶ Dispose of the cloth in an environmentally friendly manner after use.</p>

- ▶ Remove any residue of hydraulic oil from the replaced wear parts or defective components with a cloth.
- ▶ Dispose of the cloth in an environmentally friendly manner.
- ▶ Dispose of the unit in an environmentally friendly manner through the manufacturer.

In Europe

Observe and follow the regulations for disposal. If in doubt, please consult your municipal or local authority.

⚠ WARNING	
	<p>Risk of poisoning from hydraulic oil Hydraulic oil can contaminate ground water and soil.</p> <p>▶ Always dispose of hydraulic oil in an environmentally friendly manner using a specialist firm.</p>
⚠ CAUTION	
	<p>Health hazard from contact with hydraulic oil.</p> <p>▶ Wear nitrile gloves and chemical-resistant protective goggles during work that may include contact with hydraulic oil.</p>

- ▶ Dispose of hydraulic oil in an environmentally friendly manner using a specialist firm.

Replaced wear parts and defective components consist of e. g. the following materials:

- steel
- rubber
- plastic
- copper

⚠ WARNING	
	<p>Risk of poisoning from hydraulic oil Hydraulic oil can contaminate groundwater and soil.</p> <p>▶ Remove hydraulic oil from the parts to be disposed using a cloth.</p> <p>▶ Dispose of the cloth in an environmentally friendly manner after use.</p>

- ▶ With a cloth, remove traces of hydraulic oil from the unit, exchanged wearing parts or defective components.
- ▶ Dispose of the unit, replaced worn parts or defective components in accordance with environmental regulations.
- ▶ Dispose of the cloth in accordance with environmental regulations.



Technical specifications

Dimensions and weights (4-Tool adapter)	
Width:	559 mm (22.0 in)
Height:	426 mm (16.8 in)
Depth:	326 mm (12.8 in)
Weight:	about 36 kg (79.0 lbs) (Without oil fill)

Dimensions and weights (1-Tool adapter)	
Width:	556 mm (21.9 in)
Height:	426 mm (16.8 in)
Depth:	326 mm (12.8 in)
Weight:	about 33.9 kg (74.8 lbs) (Without oil fill)

Information about the hydraulics	
Oil recommendation ¹ :	Hyspin HVI 32, alternatively Bio-Hydraulic oil on mineral oil basis, e. g., Shell Naturella HFE
Recommended viscosity grades:	Starting at +10 °C (50 °F) 32-46 mm ² /s, below +10 °C (50 °F) 15-22 mm ² /s
Tank volume:	8 l (2.1 US.liq.gal)
Working pressure:	max. 700 bar (10,000 psi)

- 1 Operate the unit exclusively with clean hydraulic oil based on mineral oil. Alternatively, you can operate the unit with bio-oil based on mineral oil such as Shell Naturella HFE. In order to use the bio-oil, all the equipment of the unit must be flushed with bio-oil.

Electrical data	
Drive type:	Electric motor
Mains voltage:	115 V: 1PH90–125/60 Hz 115 V: 1PH100–115/50–60 Hz 230 V: 1PH200–230/50–60 Hz 400 V: 3PH380–460/50–60 Hz
Output:	115 V: 1.6 kW (2.1 HP), 15 A 230 V: 1.5 kW (2.0 HP), 7 A 400 V: 2.4 kW (3.3 HP), 4 A
Protection category:	IP 24
Connecting plug type	115 V: NEMA 5-15 230 V: Schuko (CEE 7/7) 400 V: CEE 400 V-5p-16 A-6h

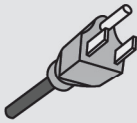

115 V

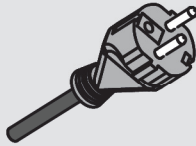

230 V

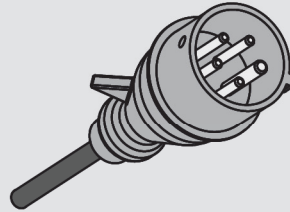

400 V

