

Bolt Tension Load Cell – Model HY-104

Basic Operations Manual

333 Route 17 N.
Mahwah, NJ 07430
USA

800-FOR-HYTORC
(800-367-4986)
201-512-9500

hytorc.com

TABLE OF CONTENTS

- Introduction 3
 - Typical Testing Applications..... 3
 - Safety 3
 - Principle of Operation..... 4
- Load cell Setup & Operation..... 5
 - Mounting the Load cell 5
 - Installing Optional Torque Reaction Kit..... 6
 - Installing Adaptors 7
 - Installing the Fastener Assembly to be Tested 8
 - How to Read the Gage 9
 - Testing Procedures 10
- Special Testing Applications..... 11
 - Testing Short Bolts 11
 - Testing Longer Bolts 12
 - Testing Tension Control (TC), “Twist-Off” Bolts 13
 - Testing F959 Direct Tension Indicating (DTI) Washers 14
- Rotational Capacity (ROCAP) Testing 16
- Calibration..... 17
- Maintenance 17
- Product Specifications 18
- Reference Information 19

Introduction

Thank you for purchasing the HYTORC HY-104 Bolt Tension Load Cell. Our improved lightweight design builds on over 60 years of industry leading experience in bolt tension measurement and calibration while maintaining the accuracy, reliability, ease of use and technical support that you have come to expect from HYTORC.

Typical Testing Applications

The load cell can be used to measure fastener tension in a wide variety of applications including but not limited to:

- Calibration of tightening tools, pre-installation verification, rotational capacity tests and other fastener tests.
- The load cell is compatible with all tightening tools including: manual and impact wrenches, pneumatic/hydraulic/electric wrenches and hydraulic tensioners, etc.
- Fastener elements that can be tested include: hex bolts, threaded studs, tension control (TC) bolts, Direct Tension Indicating (DTI) washers, anchor bolts, lock nuts, etc.

Safety



Safety First. Read all instructions, warnings and cautions carefully. Follow all safety precautions to avoid personal injury or property damage during use. HYTORC cannot be responsible for damage or injury resulting from unsafe product use, lack of maintenance or incorrect product and/or system operation. Contact HYTORC when in doubt as to the proper safety precautions and operations. **Failure to follow the proper safety procedures can cause equipment damage and/or personal injury.**

Principle of Operation

The load cell is an oil filled hydraulic design with a hole through the center of the piston & body. A sample bolt, nut, and washer, as shown in Figure 1, are installed thru the piston hole using the appropriately sized adaptors.

As the nut is tightened, the bolt stretches and the piston applies a compressive force to the hydraulic oil contained between the piston and load cell body. This force causes a pressure increase in the hydraulic oil that is proportional to the increase in bolt tension. A specially calibrated gage measures the pressure and provides a reading of equivalent **tensile force** developed in the bolt.

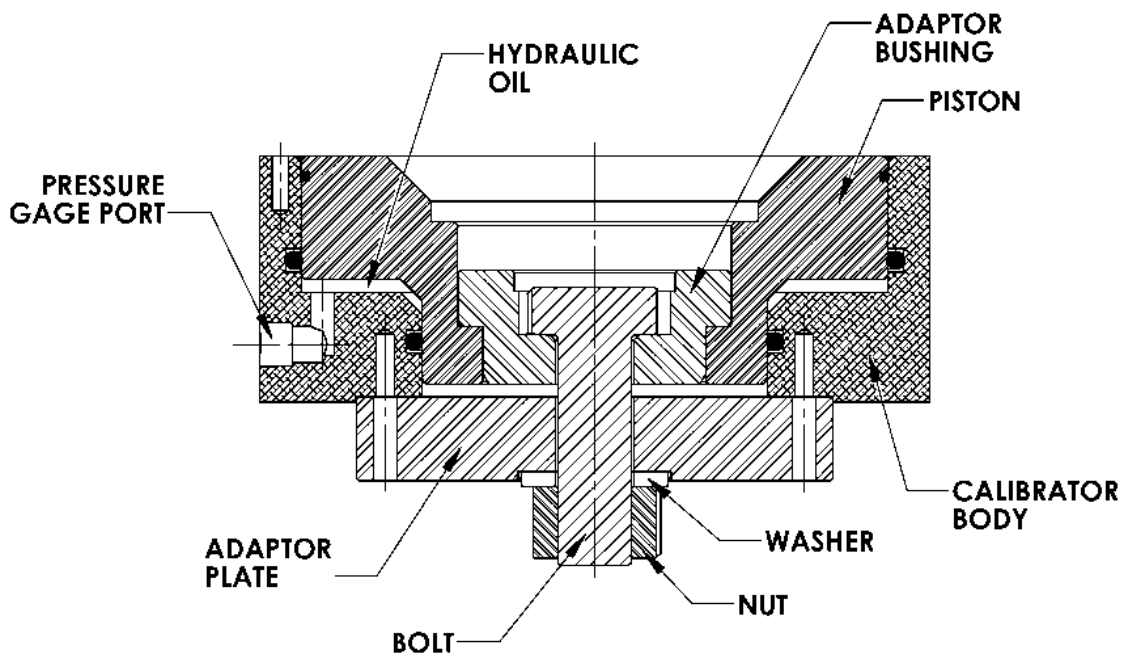


Figure 1, Typical Load cell Cross-Section

Load cell Setup & Operation

Mounting the Load Cell

The load cell should be securely fastened to a rigid I-beam or column flange using the supplied wing screws as shown in Figure 2.



Caution: Do not over tighten wing screws.

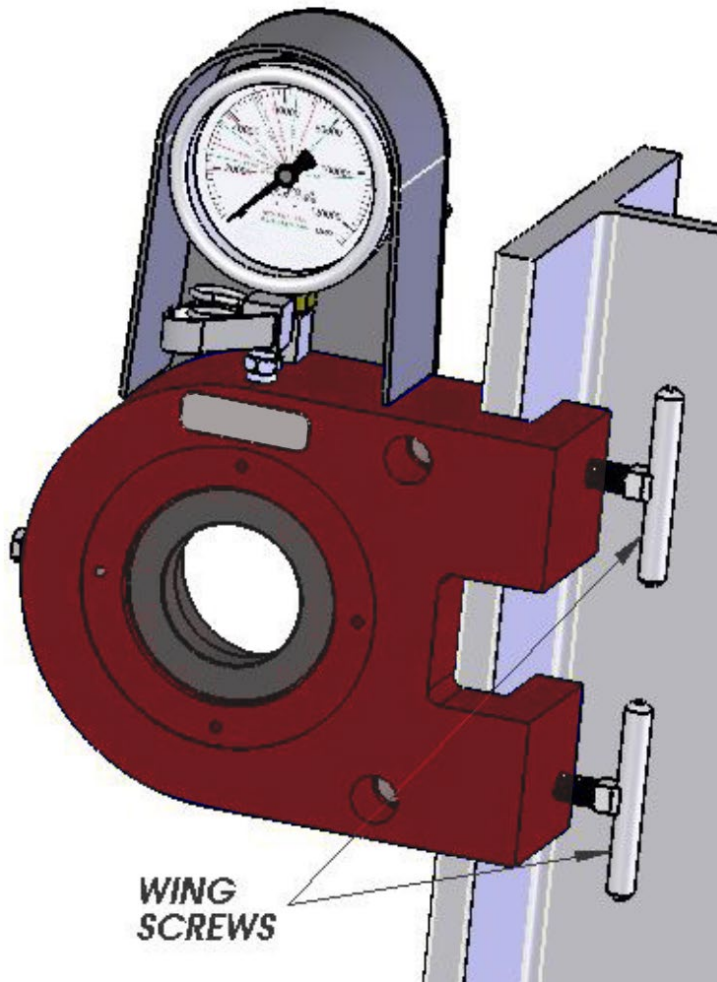


Figure 2, Typical Column Mounting

Installing Optional Torque Reaction Kit

A torque reaction kit that mounts to the load cell is required for all tightening tools with reaction arms. See Figure 3. Torque reaction kits can be purchased from HYTORC. Please contact us to determine the proper kit for your application.



Caution: Reacting against an object other than the torque reaction kit can damage the load cell and/or cause personal injury. Keep hands away from pinch points during tightening operations.

Install the torque reaction kit per the instructions supplied with the kit. Make sure to also follow the wrench manufacturer's operating and safety instructions.

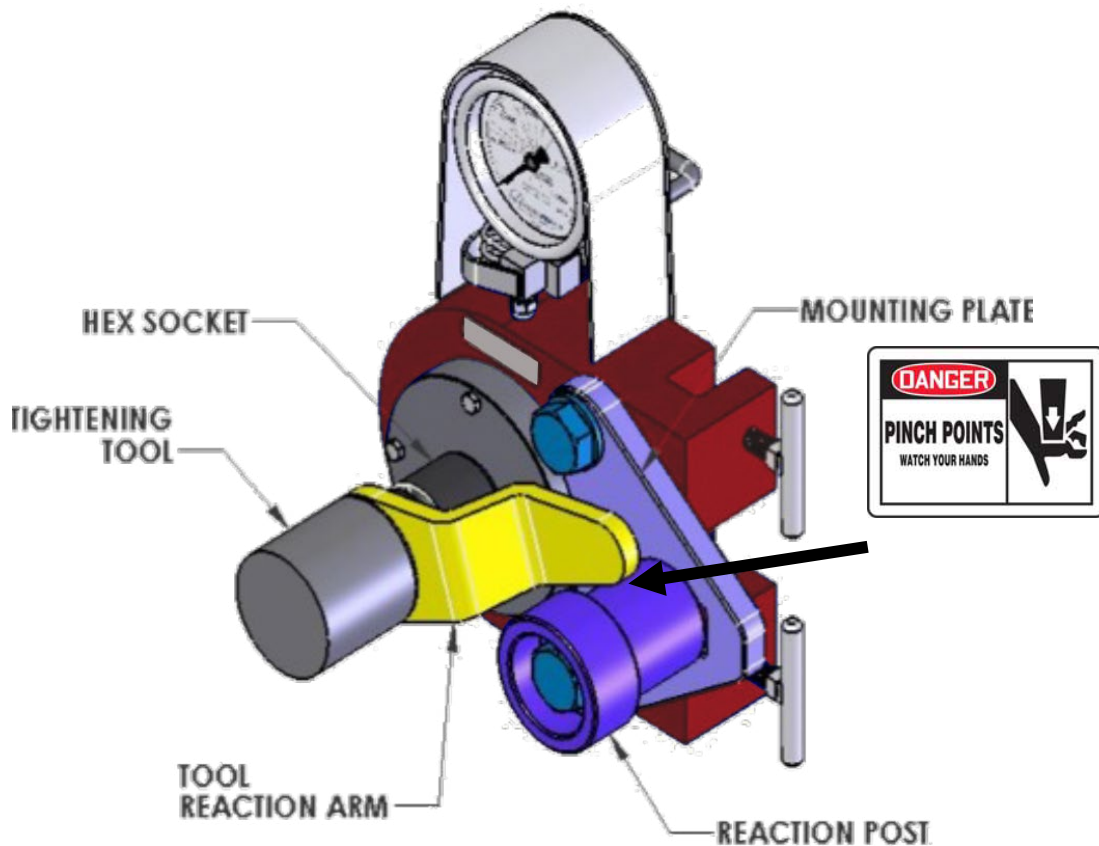


Figure 3, Typical Setup of Torque Reaction Kit

Installing Adaptors

Select the appropriate size and type of adaptor plate and bushing for the fastener assembly to be tested. HYTORC can supply a wide array of adaptors to suit your application.

Mount the adaptor plate into the counter-bore on the front of the load cell using four supplied $\frac{1}{4}$ -20 hex bolts. Snug tighten the mounting bolts.

Align the flats of the bushing to the flats of the piston pocket and insert the adaptor bushing. See Figure 6.

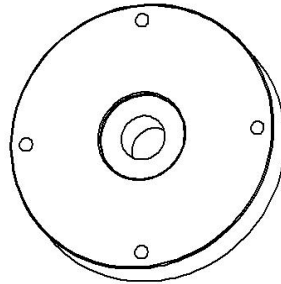


Figure 4, Typical Adaptor Plate

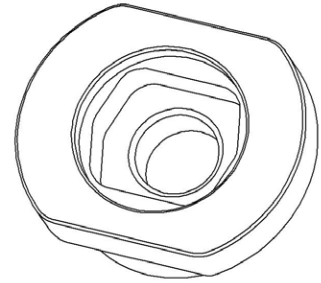


Figure 5, Typical Hex Adaptor Bushing



Make sure that the bushing is fully seated in the pocket.

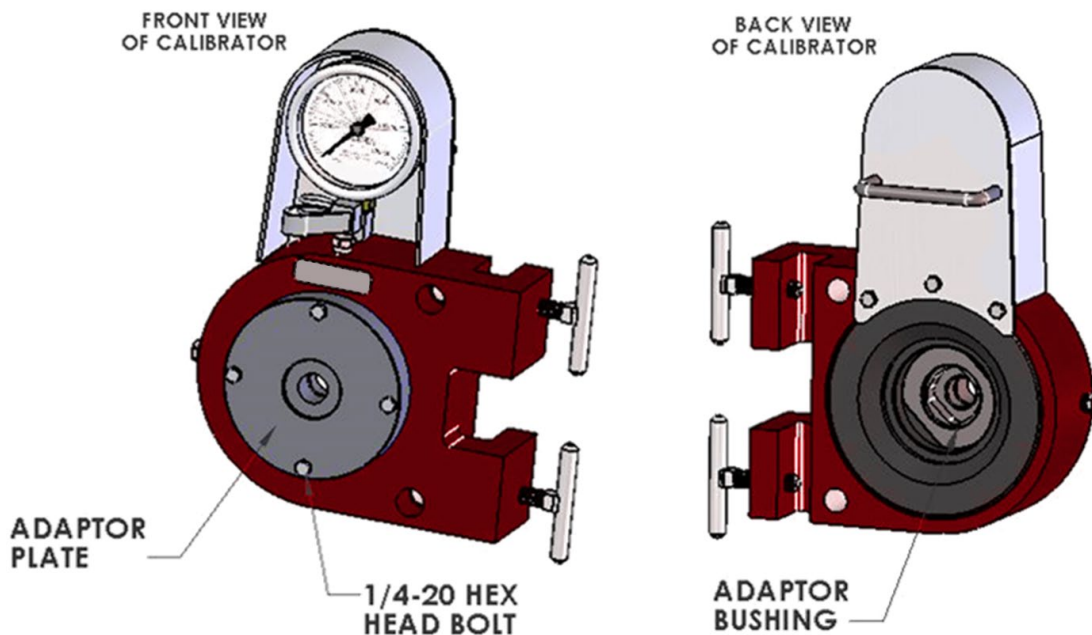


Figure 6, Installation of Adaptor Plate and Bushing

Installing the Fastener Assembly to be Tested

Install fastener assembly to be tested as follows:

- Insert the threaded end of the bolt thru the adaptor bushing from the back side of the load cell.
- Install the washer and nut on plate side. See Figure 7.
- Snug tighten and you are ready for testing.

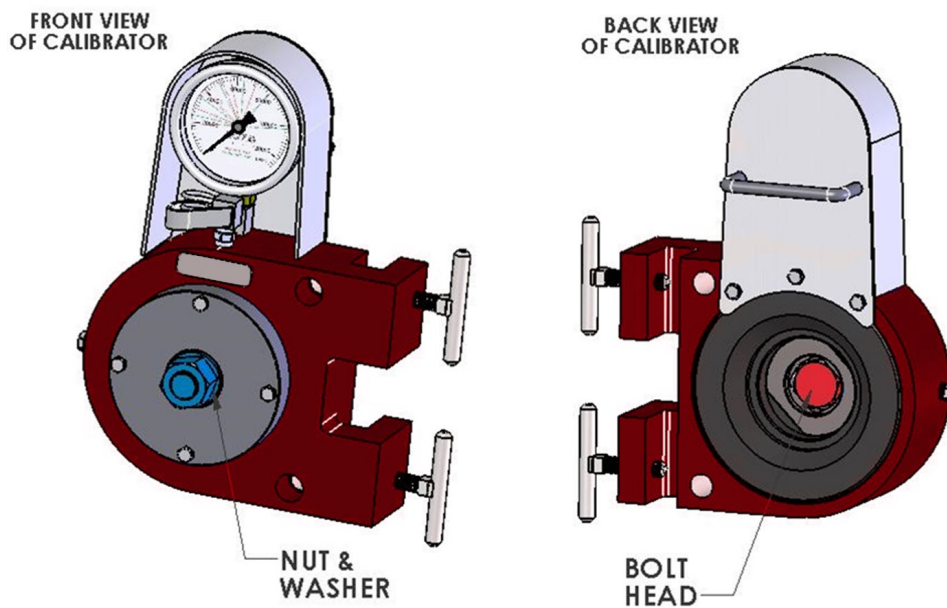


Figure 7, Installation of Fastener Assembly to be Tested

How to Read the Gage

The load cell gage measures **bolt tension** in units of pounds force (lbf). Dials with metric force units are also available.

Many engineering specifications use units of kips. Converting kips to pounds force is simple:

$$1 \text{ kip} = 1000 \text{ lbf}$$

Gage Dial Scale Resolution

The large marks are in increments of 10,000 lbf and the small marks are in increments of 2000 lbf as shown in Figure 8.

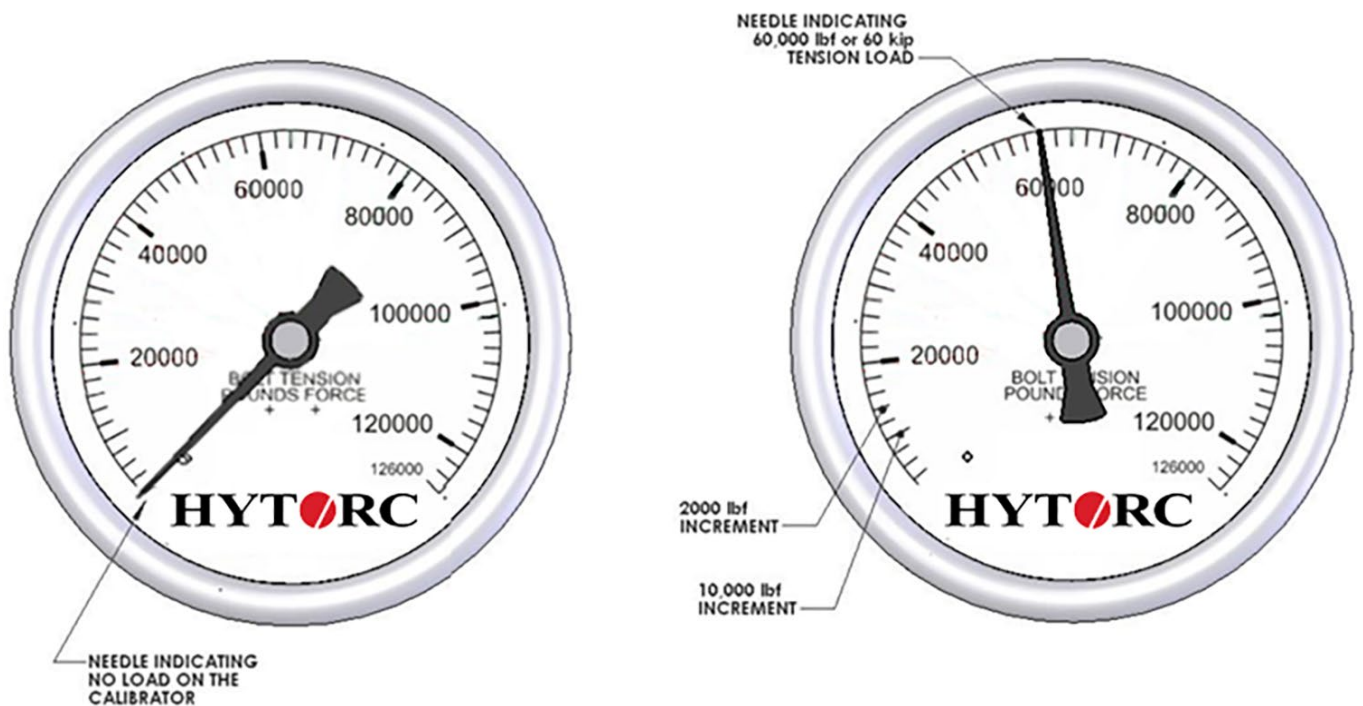


Figure 8, Example of How to Read Gage Dial

Testing Procedures

The load cell can be used for a wide variety of test procedures such as: *Pre-Installation Verification by Turn-of-Nut Method or Calibrated Wrench Method*; Rotational Capacity Testing, verification of TC Bolts & DTI washers, etc. **We have enclosed a copy of the latest edition of the *Structural Bolting Handbook* for your reference.** Be sure to check with the Steel Structures Technology Center at www.steelstructures.com for updates.

If the load cell has not been used recently, “exercise” it by tightening and loosening a bolt several times before recording test results. Once the load cell has been properly setup and “exercised”, testing can begin. **Some important points to consider:**



Please refer to your project specifications to determine the testing procedures required for your application. If in doubt, contact the Engineer of Record or relevant governing body.



DO NOT exceed the maximum range on the gage dial. This can cause pre-mature failure of the pressure gage.



DO NOT leave a bolt under tension in the load cell for an extended period of time. This can cause pre-mature failure of the sealing system.



Keep the load cell clean and free of excess oil, grease and dirt, such as zinc dust from galvanized bolts. Only use cleaning solutions that are compatible with Nitrile rubber.

Special Testing Applications

Testing Short Bolts

Bolts that are too short to be tested with standard adaptors can be tested using special Short Bolt Plates and Bushing adaptors which are marked with an "S". Minimum bolt lengths will vary with fastener diameter. See Figure 9.

We recommend using the short bolt adaptors to test short bolts only.

To maintain the strength of the adaptor plates, the recess diameter has been made as small as possible. In some cases standard sockets may not fit. HYTORC can supply specially machined sockets. Please contact us with your application.

Note: The above chart provides the minimum length bolt when using one F436 washer and a heavy hex structural nut. If other washer and nut combinations are used, such as a DTI washer, the minimum lengths will change. Please contact us for assistance.

MODEL HY-104 MINIMUM BOLT LENGTH		
Bolt Diameter	Regular Adaptors	Short Bolt Adaptors
1/2"	2"	1-1/4"
5/8"	2-1/4"	1-1/2"
3/4"	2-1/2"	1-3/4"
7/8"	2-3/4"	2"
1"	3"	2-1/4"
1-1/8"	3-1/4"	2-1/2"
1-1/4"	3-1/2"	2-3/4"

Figure 9, Minimum Bolt Length Chart

Testing Longer Bolts

Bolts that are too long to be tested with standard adaptors can be tested using Spacers and/or Spacer Bushings. HYTORC can supply standard and custom made Spacer Kits and Spacer Bushings. Please contact us with your application.



Caution: Do not use stacked washers as a “spacer”.

For impact wrenches: Up to 7-3/4” of Spacers can be used. See Figure 10. Beyond 7-3/4” it is recommended that a combination of Spacers and a Spacer Bushing be used. See Figure 11.

For manual wrenches and tightening tools with reaction arms: We recommend using spacer bushings in combination with a maximum of 1.5” of Spacers. The goal is to keep the tightening tool as close as possible to the front of the load cell. See Figure 11.

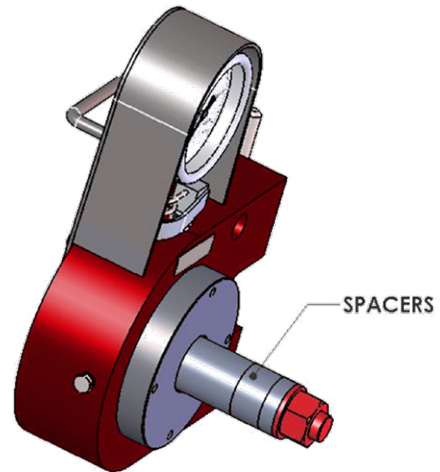


Figure 10, Typical Use of Spacers when Using an Impact Gun

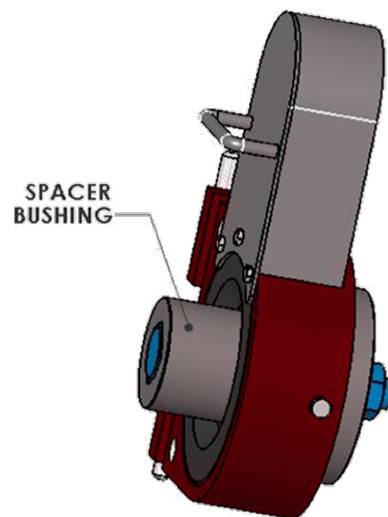


Figure 11, Typical Use of Spacer Bushings

Testing Tension Control (TC), “Twist-Off” Bolts

TC bolts have a spline at the end of the thread and may have a round or hex head and/or flange.

TC bolts are sold by the manufacturer as a pre-lubricated assembly which includes the nut and washer. See Figure 12. Proper lubrication of the nut and thread is important to the performance of this type of fastener system. Consult the fastener manufacturer/distributor if in doubt about proper lubrication conditions.

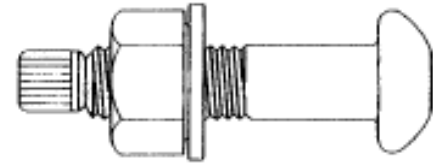


Figure 12, Typical TC Bolt

TC bolts require special installation tools but can be tested in the load cell using an appropriately sized Adaptor Plate and special counter-bored TC Adaptor Bushing, as shown in Figure 13. Standard and special bushings are available from HYTORC. Please contact us with your application.

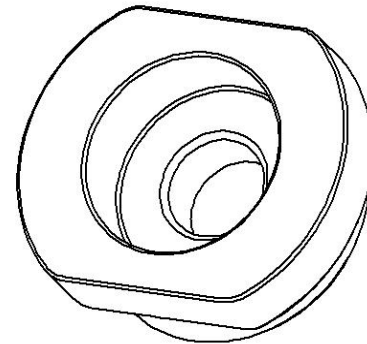


Figure 13, Counter-bored TC Adaptor Bushing



The head of the bolt should not rotate during testing. The key is to maximize the friction between the bolt head and the bearing surface of the bushing. The friction can be improved by keeping the bushing free of oil and grease and by removing lubricant from the underside of the bolt head. Contact HYTORC, if the bolt head is rotating *and* you are not obtaining required tension.

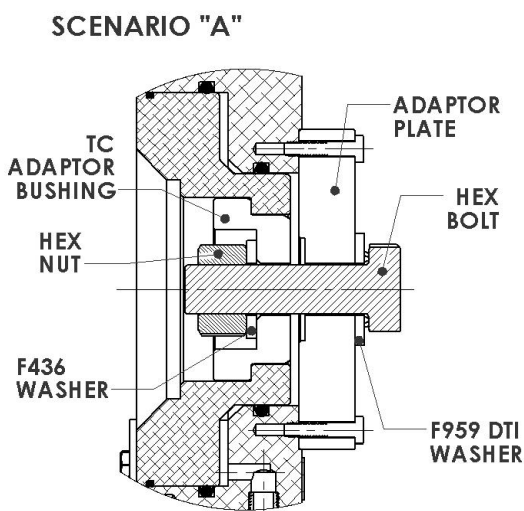
Testing F959 Direct Tension Indicating (DTI) Washers

F959 DTI washers are available in two distinct varieties: squirting and non-squirting. Both types can be tested in the load cell. There are four different setup scenarios. Each scenario is dependent on the placement of the DTI within the fastener assembly and which fastener component will be turned to tighten the assembly, i.e. nut or bolt head. Consult your project specifications and/or DTI manufacturer for the proper DTI installation procedures.

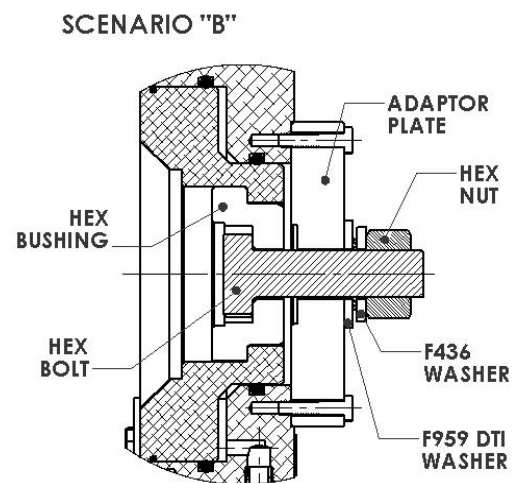


**Figure 14,
DTI Washer**

The four typical setup scenarios are shown in the following figures:



**Figure 15, Calibrator Cross-section
DTI WASHER PLACED UNDER BOLT
HEAD, NUT IS TURNED TO TIGHTEN**



**Figure 16, Calibrator Cross-section
DTI WASHER PLACED UNDER THE NUT,
NUT IS TURNED TO TIGHTEN**

Testing F959 Direct Tension Indicating (DTI) Washers (Continued)

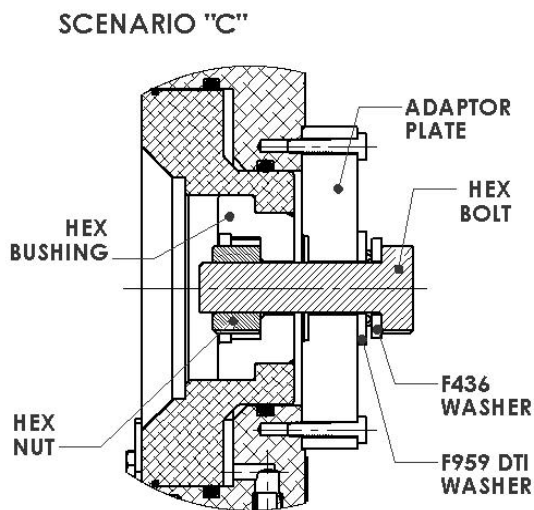


Figure 17, Calibrator Cross-section DTI WASHER PLACED UNDER BOLT HEAD, BOLT HEAD IS TURNED TO TIGHTEN

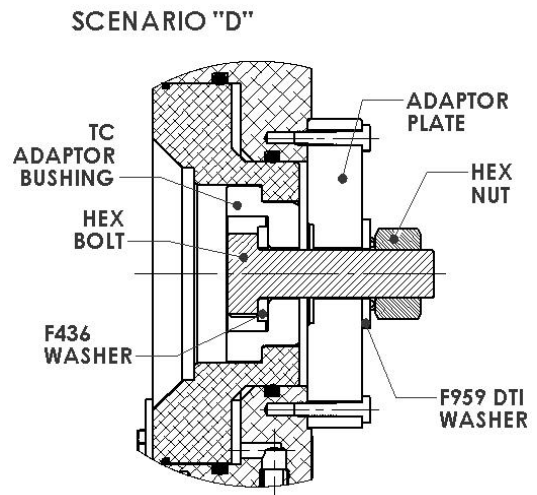


Figure 18, Calibrator Cross-section DTI WASHER PLACED UNDER THE NUT, BOLT IS TURNED TO TIGHTEN

Spacer Bushings are recommended for long bolt/DTI assemblies. Turned down sockets may be required for Scenarios "A" and "D". Please contact us with your application.

Rotational Capacity (ROCAP) Testing

Rotational capacity testing is a requirement on many projects. Consult your project specifications and/or governing body to determine your requirements.

The two most common rotational capacity test procedures are specified by:

1. American Society for Testing & Materials (ASTM) See www.astm.org for further information.
2. American Assoc. of State Highway & Transportation Officials (AASHTO). The test procedure can be downloaded at the following link:
<http://www.fhwa.dot.gov/bridge/rotational.htm>

Rotational capacity testing can be performed in the load cell by following the relevant setup procedures described in this manual.

However, Rotational capacity testing in the field can be a challenging procedure. This test, especially on plain bolts, requires quite a bit of torque. It can take as much as **twice** the torque and bolt tensions can reach **50% above** what is required for normal installation. Check with your wrench supplier to make sure you have a tool capable of running the test.



Safety should always be your highest priority. The extra rotation and higher loads unique to ROCAP testing can result in broken bolts. Make sure to always follow your standard safety practices.

Calibration

All load cells sold by HYTORC are factory calibrated using precision compression presses, dead weights and/or proving rings that are traceable to NIST standards. A written *Calibration Certificate* is included with each unit.



The load cell should only be re-calibrated by a qualified technician using NIST traceable equipment.



The load cell is calibrated as an assembly and disassembly will void the calibration. Removal of the gage for a “pressure calibration” will not provide a true calibration of the assembly.

HYTORC recommends returning your unit to the factory for re-calibration on an annual basis. This will insure that the load cell performs to original factory specifications. Please consult your own quality requirements or those of the appropriate sanctioning body to determine your required re-calibration cycle.

The following link provides detailed instructions for returning your unit for calibration:

<http://www.HYTORC.com/pdf/calibrating.pdf>



To avoid shipping damage, always ship the load cell in its original Pelican case. It is not necessary to return the adaptor plates or bushings.

Maintenance

The load cell requires minimal maintenance other than keeping it clean and dry. None of the components are user serviceable. HYTORC will replace the seals every five years as part of our recalibration service. Please consult us if you notice oil leakage or are unsure if the load cell is performing correctly.

Product Specifications

Max. Tension Measuring Capacity: 126,000 lbf (550 kN)

Measurement Accuracy: Within 1% of reading above 20,000 lbf

Calibration: Traceable to NIST

Bolt Diameter Range: ½" thru 1-1/4"

Weight (Load Cell Only): 21 lbs (9.5 kg)

Due to continual product improvements, specifications are subject to change.

Reference Information

You may find further information regarding testing procedures and best practices at the following links:

American Assoc. of State Highway & Transportation Officials (AASHTO)

www.transportation.org

American Institute of Steel Construction (AISC)

www.aisc.org

American Society for Testing & Materials (ASTM)

www.astm.org

Canadian Institute of Steel Construction (CISC)

www.cisc-issa.ca

Federal Highway Administration (FHWA)

www.fhwa.dot.gov

Industrial Fasteners Institute (IFI)

www.industrial-fasteners.org

National Institute of Standards & Technology (NIST)

www.nist.gov

Research Council on Structural Connections (RCSC)

www.boltcouncil.org

Steel Structures Technology Center, Inc. (SSTC)

www.steelstructures.com

HYTORC

HYTORC WORLD HEADQUARTERS

333 Route 17 North, Mahwah, NJ 07430 • +201-512-9500 • 800-FOR-HYTORC