



### QUICK SPECS

Scan code for full specifications.

#### TORQUE RANGE

178 - 29,650 ft.-lbs. / 241 - 40194 Nm

#### WEIGHT

4.05 - 64.70 lbs. / 1.84 - 29.41 kg

#### HEIGHT

3.53 - 10.10 in. / 90 - 257 mm

#### RADIUS

0.97 - 2.79 in. / 25 - 71 mm

## EDGE S™

### Hydraulic Torque Wrench

For general maintenance that requires high torque values and repeatable results, the **EDGE S** is HYTORC's workhorse. The straightforward 3-moving-part design was created by HYTORC over 30 years ago and has been consistently improved upon, resulting in one of the most tried and tested line of hydraulic torque wrenches in the world.

- SIMPLE OPERATION
- MULTI-AXIS SWIVEL
- REMOVABLE SQUARE DRIVE
- SAFETY HANDLE

# FULL SPECIFICATIONS

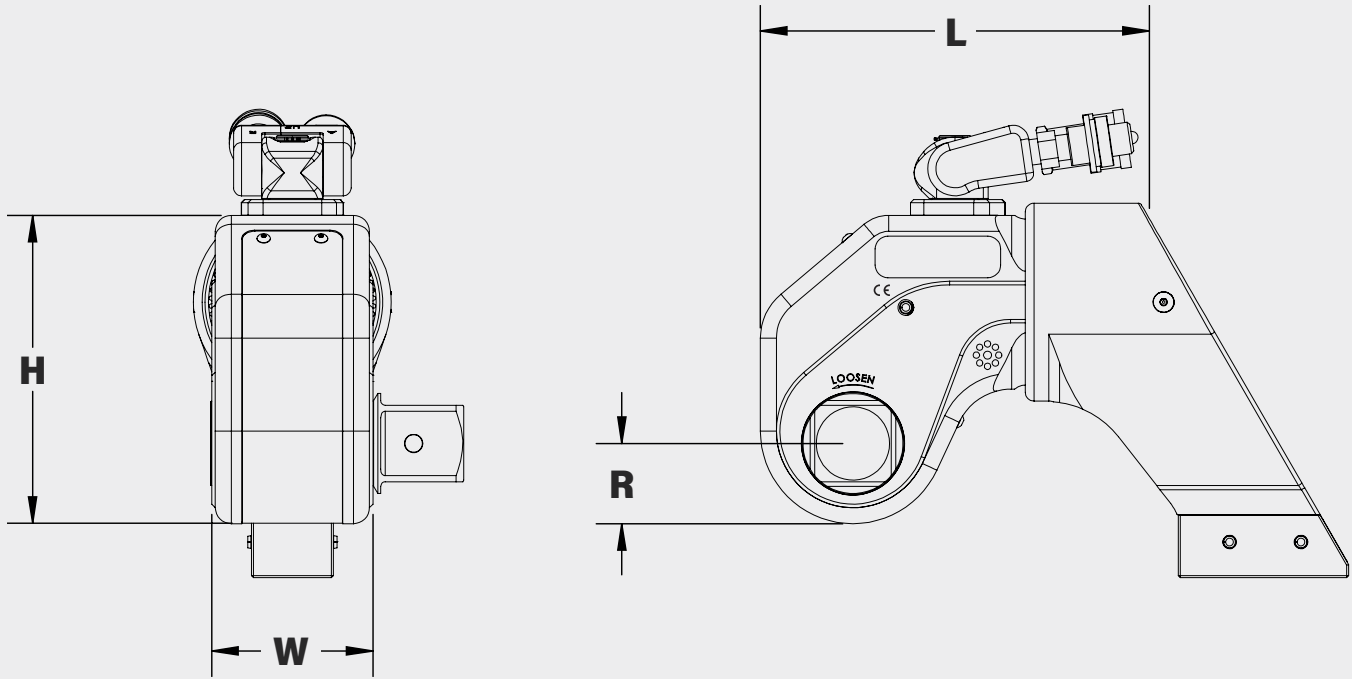

LEGEND: H = HEIGHT W = WIDTH L = LENGTH R = RADIUS

MODEL NUMBER	H	W	L	R	SQUARE DRIVE	WEIGHT	TORQUE	
IMPERIAL	in.					lbs.	ft-lbs (Min)	ft-lbs (Max)
EDGE-1S	3.53	1.97	4.94	0.97	3/4	4.05	178	1,257
EDGE-3S	4.71	2.63	6.40	1.31	1	8.50	443	3,097
EDGE-6S	6.04	3.18	7.61	1.57	1-1/2	19.20	893	6,241
EDGE-9S	6.58	3.57	8.59	1.86	1-1/2	20.05	1,230	8,555
EDGE-11S	7.07	3.95	9.60	1.96	1-1/2	25.00	1,615	11,291
EDGE-30S	10.10	5.64	13.71	2.79	2-1/2	64.70	4,448	29,650

METRIC	mm				in.	kg	Nm (Min)	Nm (Max)
EDGE-1S	90	50	125	25	3/4	1.84	241	1703
EDGE-3S	120	67	163	33	1	3.86	600	4172
EDGE-6S	153	81	193	40	1-1/2	8.73	1210	8457
EDGE-9S	167	91	221	47	1-1/2	9.11	1667	11592
EDGE-11S	180	100	244	50	1-1/2	11.36	2188	15299
EDGE-30S	257	143	348	71	2-1/2	29.41	6027	40194

HYTORC owns all content, copyrights, trademarks and patents in this document. © 2023 HYTORC. Any unauthorized use or distribution of any material from this document is strictly prohibited.



**Headquarters:**  
333 Route 17 N., Mahwah, NJ 07430  
+1-201-512-9500

**Contact:**  
1-800-FOR-HYTORC  
info@hytorc.com

**Online:**  
hytorc.com