



HYTORC REACTION WASHER



HYTORC BACKUP WASHER

HYTORC WASHER ASTM F3394/F3394M STANDARD

The HYTORC Washer system provides instant improvements in safety, speed and accuracy for most every bolting application. The HYTORC Reaction Washer and Backup Washer, when used with compatible tools, eliminate the need for reaction arms, backup wrenches and dangerous pinch points. When used as a system the HYTORC Washer provides improved speed and accuracy on every bolting job. The HYTORC Washer is manufactured in accordance with the requirements in the ASTM F3394/F3394M standard.

SAFETY

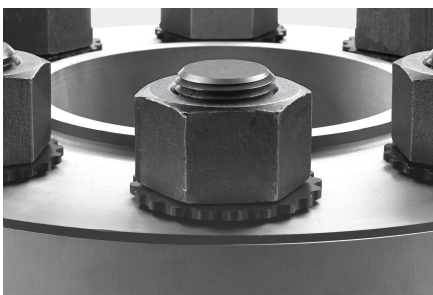

The HYTORC Reaction Washer eliminates the need for reaction arms, which are the most common cause of injury on bolting jobs. The unique design of the washer allows the dual socket driver to react on the washer, while turning the nut.

SPEED

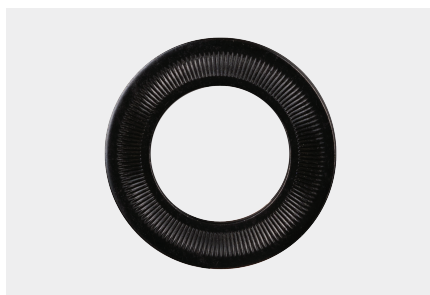

The HYTORC Backup Washer eliminates the need for backup wrenches improving the speed and efficiency of the overall bolting operation. The unique knurl design ensures the backup washer and back nut will not rotate during tightening.

ACCURACY



The HYTORC Washer System provides optimal axial tool alignment resulting in improved repeatability, reduced bolt load scatter and increased accuracy.

ASTM F3394/F3394M STANDARD SPECIFICATION FOR HARDENED STEEL BACKUP AND REACTION WASHERS INCH AND METRIC DIMENSIONS

The HYTORC Washer is manufactured in accordance with the requirements in the ASTM F3394 Standard Specification for Hardened Steel Backup and Reaction Washers. This standard covers general-purpose mechanical and structural use of washers with bolts, nuts, studs, Direct Tension Indicator washers and other threaded fasteners.

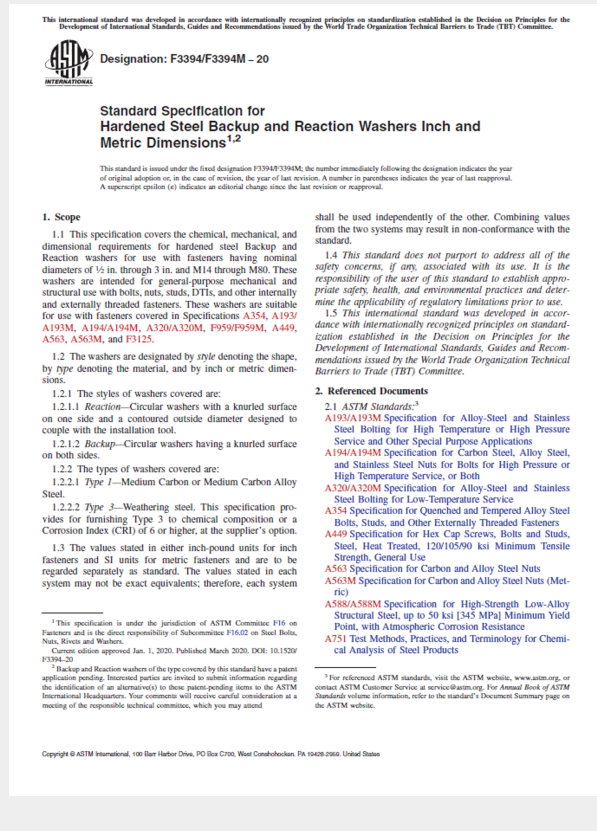

STANDARD HIGHLIGHTS

The ASTM F3394/F3394M covers:

- Reaction and Backup Washer description
- Medium Carbon and Weathering steels
- Coatings
- Mechanical properties
- Dimensions in imperial and metric
- Workmanship, finish, quality and appearance.
- Product marking
- Packaging and package marking

ASTM ORGANIZATIONAL MEMBER

ASTM International is an international standards organization that develops and publishes voluntary consensus technical standards for a wide range of materials, products, systems, and services.

ASTM standards help to improve the lives of millions every day by enhancing public safety and consumer confidence in over one hundred industries.

As an ASTM Organizational member, HYTORC is proud to have been a leading contributor to the new ASTM F3394 standard for hardened steel backup & reaction washers.



INSTALLATION TIPS

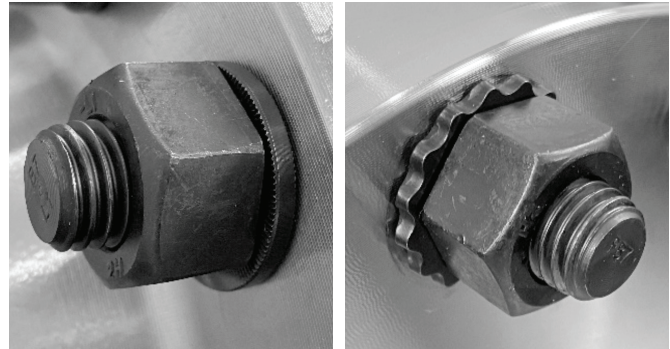

1. Allow 3/4" (0.19 mm) extra bolt length for the thickness of the reaction and backup washers.
2. Your current bolts and nuts can be used with HYTORC Washers.
3. All nuts can still be tightened or loosened using your preferred bolting method; not exclusive to HYTORC tooling.

WHERE TO GET THE STANDARD

This standard is available from the ASTM store:
astm.org/Standards/F3394

SYSTEM COMPARISON

CONVENTIONAL BOLTING CONFIGURATION

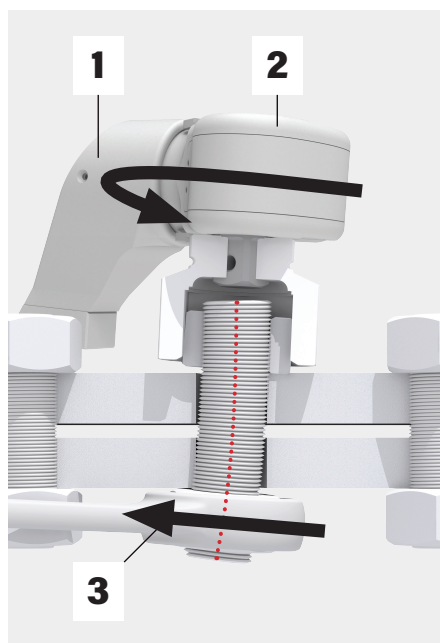

Conventional Bolting configuration:

- 1) Reaction fixture
- 2) Torque wrench
- 3) Backup wrench

Torque Application with conventional torque wrench, reaction arm and backup wrench creates significant side load, distortion of axial alignment, increases bolt load scatter and decreases accuracy.

HYTORC WASHER BOLTING CONFIGURATION

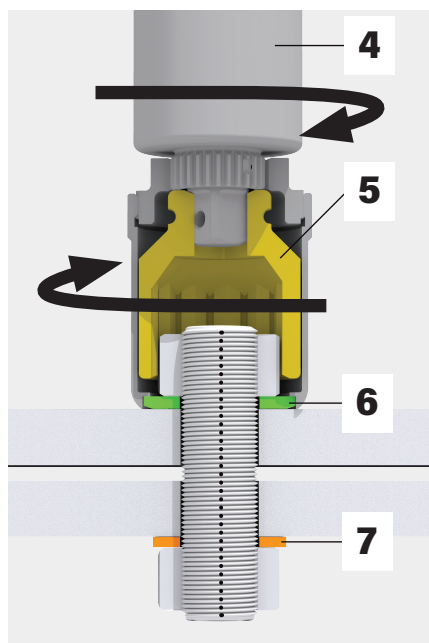

HYTORC Washer System:

- 4) Torque wrench
- 5) Dual socket driver
- 6) Reaction Washer
- 7) Backup Washer

The use of the HYTORC Washer system eliminates side load distortion, improves axial alignment, reduces bolt load scatter and improves overall accuracy.

CONVENTIONAL BOLTING EFFORT AND RISK



Conventional bolting practices require additional effort and coordination while increasing the risk of injury.

HYTORC WASHER IMPROVES SAFETY AND EFFICIENCY



The HYTORC Washer System greatly simplifies bolting operations by eliminating reaction arms, backup wrenches and associated coordination.

The combined use of the HYTORC Washer and compatible tools improves safety and efficiency.

RE-MACHINED/DAMAGED FLANGE SURFACE

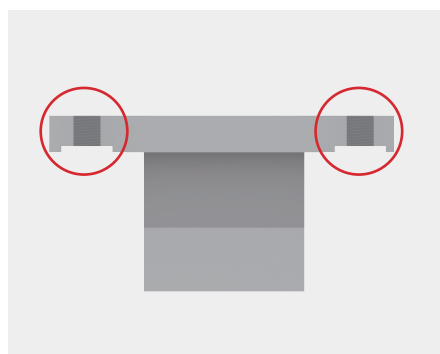

Repeated tightening and loosening of nuts without the use of a washer will cause extended wear and damage to the flange, requiring costly re-machining during maintenance activities.

FLANGE PROTECTION

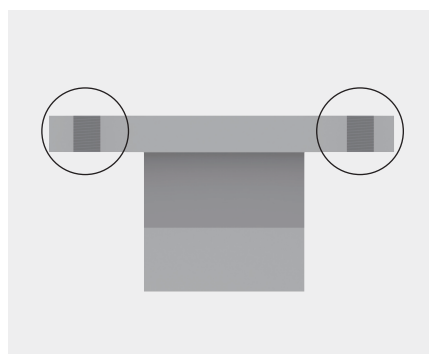

The HYTORC Washer protects flange surfaces, eliminating the need for expensive resurfacing and extending flange life.

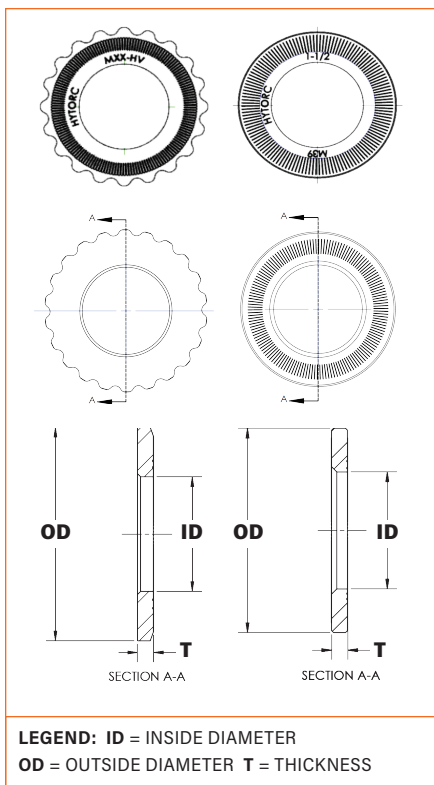

LEGEND: ID = INSIDE DIAMETER
OD = OUTSIDE DIAMETER T = THICKNESS

REACTION WASHER - IMPERIAL (in.)

BOLT SIZE	PART NUMBER	ID	OD	T
1/2"	ZRW-008	0.531	1.118	0.123
9/16"	ZRW-009	0.625	1.219	0.123
5/8"	ZRW-010	0.688	1.432	0.130
3/4"	ZRW-012	0.813	1.600	0.152
7/8"	ZRW-014	0.938	1.865	0.152
1"	ZRW-100	1.063	2.057	0.158
1-1/8"	ZRW102-M30	1.241	2.307	0.190
1-1/4"	ZRW104-M33	1.346	2.492	0.190
1-3/8"	ZRW106-M36	1.497	2.742	0.190
1-1/2"	ZRW108-M39	1.592	2.928	0.190
1-5/8"	ZRW110-M42	1.703	3.179	0.245
1-3/4"	ZRW112-M45	1.823	3.355	0.245
1-7/8"	ZRW114-M48	1.977	3.617	0.245
2"	ZRW200-M52	2.135	3.787	0.245
2-1/4"	ZRW204	2.341	4.280	0.298
2-1/2"	ZRW208-M64	2.662	4.768	0.335
2-3/4"	ZRW-212	2.863	5.265	0.335
3"	ZRW-300	3.117	5.595	0.405

BACKUP WASHER - IMPERIAL (in.)

BOLT SIZE	PART NUMBER	ID	OD	T
1/2"	ZBW-008	0.531	1.005	0.120
9/16"	ZBW-009	0.625	1.086	0.120
5/8"	ZBW-010	0.688	1.227	0.130
3/4"	ZBW-012	0.813	1.449	0.150
7/8"	ZBW-014	0.938	1.650	0.150
1"	ZBW-100	1.063	1.870	0.160
1-1/8"	ZBW102-M30	1.236	2.092	1.190
1-1/4"	ZBW104-M33	1.346	2.309	0.190
1-3/8"	ZBW106-M36	1.492	2.526	0.190
1-1/2"	ZBW108-M39	1.592	2.742	0.190
1-5/8"	ZBW110-M42	1.703	2.959	0.250
1-3/4"	ZBW112-M45	1.818	3.175	0.250
1-7/8"	ZBW114-M48	1.972	3.392	0.250
2"	ZBW200-M52	2.130	3.608	0.260
2-1/4"	ZBW204-M56	2.336	4.120	0.300
2-1/2"	ZBW208-M64	2.657	4.500	0.340
2-3/4"	ZBW212-M72	2.858	4.920	0.340
3"	ZBW-300	3.112	5.250	0.410

PART DESIGNATION

ZXW-XXX-YY-Z

R-Reaction
B-Backup
Part Number
Finish Code
Material Code*

ZXWXXX-XXX-YY-Z

R-Reaction
B-Backup
Part Number
Finish Code
Material Code*

* Material code is used when alternative coatings and materials are specified. Please contact HYTORC for more information.

REACTION WASHER - METRIC (mm)

BOLT SIZE	PART NUMBER	ID	OD	T
M14	ZRW-M14	14.99	28.40	3.1
M16	ZRW-M16	16.99	30.96	3.1
M18	ZRW-M18	19.23	36.37	3.3
M20	ZRW-M20	21.11	37.01	3.3
M22	ZRW-M22	23.09	40.64	3.3
M24	ZRW-M24	25.32	47.37	4.1
M27	ZRW-M27	28.70	52.25	4.1
M30	ZRW102-M30	31.39	58.60	4.8
M33	ZRW104-M33	34.19	63.30	4.8
M36	ZRW106-M36	37.90	69.65	4.8
M39	ZRW108-M39	40.44	74.37	4.8
M42	ZRW110-M42	43.26	80.75	6.4
M45	ZRW112-M45	46.18	85.22	6.4
M48	ZRW114-M48	50.09	91.87	6.4
M52	ZRW200-M52	54.10	96.19	6.4
M60	ZRW-M60	64.01	108.71	7.6
M64	ZRW208-M64	67.49	121.11	8.6
M68	ZRW-M68	70.10	121.11	8.6
M72	ZRW-M72	73.91	133.73	8.6
M76	ZRW-M76	77.98	133.73	8.6
M80	ZRW-M80	82.04	142.11	10.0

BACKUP WASHER - METRIC (mm)

BOLT SIZE	PART NUMBER	ID	OD	T
M14	ZBW-M14	14.99	25.53	3.1
M16	ZBW-M16	16.99	27.58	3.1
M18	ZBW-M18	19.23	31.17	3.3
M20	ZBW-M20	21.11	34.65	3.3
M22	ZBW-M22	23.09	36.8	3.9
M24	ZBW-M24	25.32	41.91	4.0
M27	ZBW-M27	28.7	47.5	4.0
M30	ZBW102-M30	31.39	53.14	4.8
M33	ZBW104-M33	34.19	58.65	4.8
M36	ZBW106-M36	37.90	64.16	4.8
M39	ZBW108-M39	40.44	69.65	4.8
M42	ZBW110-M42	43.26	75.16	6.4
M45	ZBW112-M45	46.18	80.65	6.4
M48	ZBW114-M48	50.09	86.16	6.4
M52	ZBW200-M52	54.10	91.64	6.4
M60	ZBW-M60	59.33	104.65	7.4
M64	ZBW208-M64	67.49	114.30	8.5
M68	ZBW-M68	70.10	114.30	8.5
M72	ZBW212-M72	72.59	124.97	8.5
M76	ZBW-M76	77.98	124.97	8.5
M80	ZBW-M80	82.04	133.35	10.3

Nominal dimensions for reference only.



Headquarters:
333 Route 17 N., Mahwah, NJ 07430
+1-201-512-9500

Email:
info@hytorc.com

Phone:
1-800-FOR-HYTORC

Online:
hytorc.com