

HYTORC



jGun® Single and Dual Speed Pneumatic Torque Tools Basic Operations Manual

333 Route 17 N.
Mahwah, NJ 07430
USA

800-FOR-HYTORC
(800-367-4986)
201-512-9500

hytorc.com

TECHNICAL CERTIFICATIONS

Models

jGun® SINGLE SPEED:
J-.25, J-.5, J-1, J-3, J-5, J-8

jGun® DUAL SPEED:
J-A.5-AP, J-A1-AP, J-A3-AP,
J-A5-AP, J-A8-AP

Technical Certifications

For a complete EC declaration of conformity or if you require any further assistance please call your local HYTORC Representative or 1-800-FOR-HYTORC (1-800-367-4986). Please visit us at HYTORC.com.

333 Route 17 N, Mahwah NJ 07430
1-800-FOR-HYTORC
hytorc.com

Notice. The information contained in this document is subject to change without notice. HYTORC makes no warranty of any kind with regard to this material, including but not limited to, the implied warranties of merchantability and fitness for a particular purpose. HYTORC shall not be liable for errors contained herein or for incidental or consequential damages in connection with the furnishing, performance, or use of this material. It is further recommended that the end-user or repair technician insure they have obtained and are familiar with the latest revision of the manual for the equipment outlined in this document.

Restricted Rights Legend. Use and duplication of the information contained within this manual is limited to the purchaser, end user, or licensed HYTORC representative. It is recommended that proper training for the equipment outlined in this manual be conducted by a HYTORC-authorized training representative for any person who is operating or repairing the equipment outlined in this document. Modification of, or disclosure by any other agency or representative is strictly forbidden.

Product Modifications. HYTORC DOES NOT ALLOW any of the products listed in this manual to be modified by any end user without exception. Should an application require a modification to the tool, or any of the standard accessories please consult with your local HYTORC representative and they will be able to obtain the assistance for any modification that may be required.

jGun® is a registered trademark of HYTORC.

Copyright © 2024 HYTORC All Rights Reserved. Reproduction, adaptation, or translation without prior written permission is prohibited, except as allowed under the copyright laws.

Warranty. The jGun® Pneumatic Torque Tools (SINGLE SPEED and DUAL SPEED Models) have a One-Year Hassle-Free Warranty. Every tool is tested before leaving the factory and is warranted to be free from defects in workmanship and materials. HYTORC will repair or replace, without charge, any tool which, upon examination, proves to be defective in workmanship or materials for one (1) year after the date of purchase. This warranty does not cover damage resulting from repairs made or attempted by unauthorized repair facilities. The repair and replacement remedies described herein are exclusive. In no event shall HYTORC be liable for any incidental, special, or consequential damages, including loss of profits. This warranty is exclusive and in lieu of all other warranties or conditions, written or oral, expressed or implied for merchantability or fitness for particular use or purpose. This warranty gives you specific legal rights. You may also have other rights that vary from state to state and province to province. In those states that do not allow the exclusion of implied warranties or limitation of incidental or consequential damages, the above limitations or exclusions may not apply to you. If you have questions about the warranty, contact our customer service center at 201-828-5270.

Printed in the USA. October 2024

TABLE OF CONTENTS

GENERAL SAFETY INFORMATION	1
EMISSIONS	6
WARRANTY	8
jGun OVERVIEW	8
jGun SAFETY	9
jGun SETUP AND USE	15
jGun REPAIR AND MAINTENANCE	19
jGun DUAL SPEED PNEUMATIC TORQUE TOOL	20
FILTER/REGULATOR/LUBRICATOR (FRL) UNIT OVERVIEW	23
FRL SETUP AND USE	25
HYTORC WASHER OVERVIEW	30
jGun MAINTENANCE AND TROUBLESHOOTING TIPS	35
CHANGELOG	36
MISSION STATEMENT	37

NOTICE OF PROPRIETARY RIGHTS: HYTORC Division UNEX Corporation ("HYTORC") is the owner of all content included in this document and all right, title and interest to such content shall remain with HYTORC. **COPYRIGHT NOTICE:** © 2024 HYTORC. Any unauthorized use or distribution of any material from this document, without HYTORC's written permission, is strictly prohibited. **TRADEMARK NOTICE:** This document contains numerous registered trademarks and servicemarks of HYTORC in the U.S. and other countries. **PATENT NOTICE:** Products in this document are covered by numerous registered and/or pending patents in the U.S. and other countries.



WARNING! Read all safety warnings designated by the  symbol and all instructions.



WARNING! Read all instructions before use. To reduce the risk of injury user must read manual.

Instructions in this section are compliant with ISO-11148-6:2012 and ISO-12100:2010.

1. GENERAL

- **Employer Responsibility:** The user's employer shall assess the specific risks that can be present as a result of each use.
- **Maintenance Instructions:** General maintenance recommendations included in this document include care and handling instructions (see Section 4) and cleaning the filters (see Section 6).
- **Special Markings on the Tool:** There are no special markings or symbols on the tool.
- **Residual Risks:** When this tool is used for its intended purpose by trained individuals equipped with adequate personal protective equipment according to the instructions in this document, there are no known residual risks.
- **Statement of Use:** The jGun **DIGITAL Single Speed** Pneumatic Torque Tool is intended for use in tightening fasteners with controlled torque in heavy duty industrial bolting applications.
- **Trained User Only:** This tool should be used only by fully trained personnel, and this document is written only for trained professionals. This tool should not be used without proper training and supervision. Contact HYTORC for additional information on receiving proper training for this tool.

2. GENERAL SAFETY RULES

- Maintenance must be performed by a qualified HYTORC technician.
- Operating the tool in any fashion other than as described herein can result in serious bodily injury and is forbidden.
- For multiple hazards, read and understand the safety instructions before installing, operating, repairing, maintaining, changing accessories on, or working near the assembly power tool for threaded fasteners (the "tool"). Failure to do so can result in serious bodily injury.
- Only qualified and trained operators should install, adjust or use the tool.
- Do not modify this tool. Modification of the tool invalidates the warranty and can reduce the effectiveness of safety measures and increase the risks to the operator.
- Do not discard the safety instructions; give them to the operator.
- Do not use the tool if it has been damaged.
- Tools shall be inspected periodically to verify that the ratings and markings are legibly marked on the tool. The employer/user shall contact the manufacturer to obtain replacement marking labels when necessary.

3. PROJECTILE HAZARD

- Failure of the workpiece, of accessories or even of the inserted tool itself can generate high-velocity projectiles.
- Always wear impact-resistant eye protection during operation of the tool. The grade of protection required should be assessed for each use.
- Ensure that the workpiece is securely fixed.

4. ENTANGLEMENT HAZARDS

- Entanglement hazards can result in choking, scalping and/or lacerations if loose clothing, personal jewelry, neckwear, hair or gloves are not kept away from the tool and accessories.
- Gloves can become entangled with the rotating drive, causing severed or broken fingers.
- Rotating drive sockets and drive extensions can easily entangle rubber-coated or metal-reinforced gloves.
- Do not wear loose-fitting gloves or gloves with cut or frayed fingers.
- Never hold the drive, socket or drive extension while operating tool.
- Keep hands away from rotating drives.

5. OPERATING HAZARDS

- The use of the tool can expose the operator's hands to hazards including crushing, impacts, cuts and abrasions and heat. Wear suitable gloves to protect hands.
- Operators and maintenance personnel must be physically able to handle the bulk, weight and power of the tool.
- Hold the tool correctly; be ready to counteract normal or sudden movements and have both hands available.
- Maintain a balanced body position and secure footing.
- In cases where the means to absorb the reaction torque are requested, it is recommended to use a suspension arm whenever possible. If that is not possible, side handles are recommended for straightcase and pistol-grip tools. Reaction bars are recommended for angle nutrunners. In any case, it is recommended to use a means to absorb the reaction torque above 4 N·m for straight tools, above 10 N·m for pistol-grip tools, and above 60 N·m for angle nutrunners.
- Release the start-and-stop device in case of an interruption of the energy supply.
- Use only lubricants recommended by the manufacturer.
- Beware of crushing hands between tool and workpiece, especially when unscrewing.

6. REPETITIVE MOTIONS HAZARDS

- When using tool the operator can experience discomfort in hands, arms, shoulders, neck, or other parts of the body.
- The operator should adopt a comfortable posture while maintaining secure footing and avoiding awkward or off-balanced postures. The operator should change posture during extended tasks to help avoid discomfort and fatigue.
- If the operator experiences symptoms such as persistent or recurring discomfort, pain, throbbing, aching, tingling, numbness, burning sensations or stiffness, these warning signs should not be ignored. The operator should tell the employer and consult a qualified health professional.

7. ACCESSORY HAZARD

- Disconnect tool from the energy supply before changing the inserted tool or accessory.
- Do not touch sockets or reaction arms during use, as this can cause serious injury.
- Use only sizes and types of accessories that are recommended by the tool manufacturer.
- Use only impact grade sockets in good condition, as sockets in poor condition can shatter and become a projectile.

8. WORKPLACE HAZARDS

- Slips, trips and falls are major causes of workplace injury. Be aware of slippery surfaces caused by the use of the tool and also of trip hazards caused by the air line or hydraulic hose.
- Proceed with care in unfamiliar surroundings. Hidden hazards, such as electricity or other utility lines, can exist.
- The tool is not intended for use in potentially explosive atmospheres and is not insulated against electric power.
- Make sure there are no electrical cables, gas pipes, etc., that can cause a hazard if damaged by use of the tool.

9. DUST AND FUME HAZARDS

- Where dust or fumes are present in the environment where this tool is used, follow instructions as required by the employer and occupational health and safety regulations to provide respiratory protection for tool users.
- Dust and fumes generated when using power tools can cause ill health (for example cancer, birth defects, asthma and/or dermatitis); risk assessment and implementation of appropriate controls for these hazards are essential.

10. NOISE HAZARDS

- Exposure to high noise levels can cause permanent, disabling hearing loss and other problems, such as tinnitus (ringing, buzzing, whistling or humming in the ears). Therefore a risk assessment and implementation of appropriate controls for these hazards are essential.
- Appropriate controls to reduce risk may include damping materials to prevent workpieces from “ringing”.
- Use hearing protection in accordance with instructions and as required by health and safety regulations.
- Operate and maintain the tool as recommended in instructions, to prevent increase in noise levels.
- If the tool has a silencer, always ensure it is in place and in good working order when operating.
- Select, maintain and replace tool as required to prevent an unnecessary increase in noise.

11. VIBRATION HAZARDS

- Exposure to vibration can cause disabling damage to the nerves and blood supply of the hands and arms.
- Keep hands away from the nutrunner sockets.
- If you experience numbness, tingling, pain or whitening of the skin in your fingers or hands, stop using the tool, tell your employer and consult a physician.
- Operate and maintain the tool as recommended, to prevent unnecessary increase in vibration levels.
- Do not use worn or ill-fitting sockets or extensions, as this is likely to cause a substantial increase in vibration.
- Select, maintain and replace tool as required to prevent an unnecessary increase in vibration levels.
- Sleeve fittings should be used where practicable.
- Hold the tool lightly but securely; the risk from vibration is generally greater with a tighter grip.

12. ADDITIONAL SAFETY INSTRUCTIONS FOR PNEUMATIC POWER TOOLS

- Air pressure has a safety critical effect on performance. Be sure to follow requirements for hose length and diameter as air under pressure can cause severe injury.
- Always shut off air supply, drain hose of air pressure and disconnect tool from air supply when not in use, before changing accessories or when making repairs.
- Never direct air at yourself or anyone else.
- Whipping hoses can cause severe injury. Always check for damaged or loose hoses and fittings.
- Cold air shall be directed away from the hands.
- Do not use quick-disconnect couplings at tool inlet for impact and air-hydraulic impulse wrenches. Use hardened steel (or material with comparable shock resistance) threaded hose fittings.
- Whenever universal twist couplings (claw couplings) are used, lock pins shall be installed and whip check safety cables shall be used to safeguard against possible hose-to-tool and hose-and-hose connection failure.
- Do not exceed the maximum air pressure stated on the tool.
- Never carry tool by the hose.

13. EMISSIONS STATEMENT

- The noise emission, measured in accordance with EN ISO 15744, using, as basic standards, EN ISO 3744 and EN ISO 11203, is as follows:
 - A-weighted sound pressure level $L_{pA} = 99.3 \text{ 70 dB(A)}$ and its uncertainty $K_{pA} = 3\text{dB(A)}$
 - A-weighted sound power level $L_{WA} = 110.3 \text{ dB (A)}$ and its uncertainty $K_{WA} = 3\text{dB(A)}$
 - Operating conditions: No load

NOTE: The sum of a measured noise emission value and its associated uncertainty represents an upper boundary of the range of values, which is likely to occur in measurements.

- The declared vibration emission value and its uncertainty measured in accordance with EN ISO 28927-2, is:
 - The declared vibration emission value $a_{hd} = 1.10 \text{ m/s}^2$ and its uncertainty $K = 1.50 \text{ m/s}^2$
- The declared vibration total value has been measured in accordance with a standard test method and may be used for comparing one tool with another.
- The declared vibration total value may also be used in a preliminary assessment of exposure.
- The vibration emission during actual use of the tool can differ from the declared total value depending on the ways in which the tool is used.
- Identify safety measures to protect the operator that are based on an estimation of exposure in the actual conditions of use (taking account of all parts of the operating cycle such as the times when the tool is switched off and when it is running idle in addition to the trigger time).

14. GENERAL OPERATOR GUIDELINES

Only qualified personnel who have thoroughly read this document may operate this tool. Failure to safely operate this tool may result in serious injury or death.

- Do not submerge in water or subject tool to extreme humidity.
- Do not subject tool to extreme temperature variations.
- Do not operate tool in temperatures above 140°F (60°C) or below -14°F (-25°C).
- Do not subject tool to dusty environments that could clog the vents. Keep vents clear and uncovered.
- Wear warm clothing when working in cold conditions and keep hands warm and dry.

15. PERSONAL PROTECTIVE EQUIPMENT (PPE)

- Always wear appropriate protective equipment, including gloves, impact-resistant eye protection, hearing protection, hard hat and safety shoes, when operating tool. The grade of protection required should be assessed for each use.

16. TOOL SPECIFICATIONS

jGun SINGLE SPEED

MODEL NUMBER	H	W	L	D	SQUARE DRIVE	WEIGHT	TORQUE		RPM
IMPERIAL	in.					lbs.	ft-lbs (Min)	ft-lbs (Max)	
J -.25	7.32	2.74	7.03	2.50	3/4	7.20	48	250	65.0
J -.5	7.32	2.74	8.07	2.58	3/4	7.20	129	508	24.0
JGUN-A.7-HS	7.94	3.53	9.93	2.58	3/4	10.40	175	725	26.0
J - 1	7.32	2.74	8.90	2.58	3/4	10.00	301	1231	6.5
J - 2	7.94	3.53	10.46	3.25	1	14.50	521	2190	5.5
J - 3	7.94	3.53	11.11	3.25	1	15.74	852	3104	5.0
J - 5	8.25	4.15	12.68	4.15	1-1/2	20.05	1150	5266	2.5
J - 8	8.46	4.56	13.90	4.56	1-1/2	26.50	1743	7924	1.5

METRIC	mm				in.	kg	Nm (Min)	Nm (Max)	RPM
J -.25	186	70	179	64	3/4	3.27	65	339	65.0
J -.5	186	70	205	66	3/4	3.27	175	688	24.0
JGUN-A.7-HS	202	90	252	66	3/4	4.73	237	982	26.0
J - 1	186	70	226	66	3/4	4.55	408	1668	6.5
J - 2	202	90	266	83	1	6.59	706	2967	5.5
J - 3	202	90	282	83	1	7.15	1154	4206	5.0
J - 5	210	105	322	105	1-1/2	9.11	1558	7136	2.5
J - 8	215	116	353	116	1-1/2	12.05	2362	10737	1.5

jGun DUAL SPEED

MODEL NUMBER	H	L	D	DC	SQUARE DRIVE	WEIGHT	TORQUE		RPM	
IMPERIAL	in.					lbs.	ft-lbs (Min)	ft-lbs (Max)	High	Low
J - A.5 - AP	7.32	8.07	2.58	2.99	3/4	9.04	194	502	465	24.0
J - A1 - AP	7.40	10.55	2.58	2.99	3/4	9.70	312	1,272	126	6.5
J - A2 - AP	8.42	12.51	3.25	4.48	1	15.00	520	2,039	97	5.0
J - A3 - AP	7.50	12.48	3.19	2.99	1	12.00	830	3,072	39	2.0
J - A5 - AP	8.42	14.65	4.15	4.48	1-1/2	22.50	1,215	5,007	48	2.5
J - A8 - AP	8.46	15.38	4.56	4.48	1-1/2	28.75	2,079	8,285	29	1.5
WHEEL GUN J - A1 - AP - WG	7.40	10.55	2.58	2.99	3/4	12.0	255	1,075	322	17

METRIC	mm				in.	kg	Nm (Min)	Nm (Max)	High	Low
J - A.5 - AP	186	205	66	76	3/4	4.11	263	680	465	24.0
J - A1 - AP	188	268	66	76	3/4	4.41	423	1724	126	6.5
J - A2 - AP	214	318	83	114	1	6.82	705	2763	97	5.0
J - A3 - AP	191	317	81	76	1	5.45	1125	4163	39	2.0
J - A5 - AP	214	372	105	114	1-1/2	10.23	1646	6785	48	2.5
J - A8 - AP	215	391	116	114	1-1/2	13.07	2817	11226	29	1.5
WHEEL GUN J - A1 - AP - WG	188	268	66	76	3/4	5	346	1457	322	17

Emissions

The noise emission, measured in accordance with EN ISO 15744, using, as basic standards, EN ISO 3744 and EN ISO 11203, is as follows:

- A-weighted sound pressure level $L_{pA} = 99.3 \text{ dB(A)}$ and its uncertainty $K_{pA} = 3\text{dB(A)}$
- A-weighted sound power level $L_{WA} = 110.3 \text{ dB (A)}$ and its uncertainty $K_{WA} = 3\text{dB(A)}$
- Operating conditions: No load

NOTE 1: The sum of a measured noise emission value and its associated uncertainty represents an upper boundary of the range of values, which is likely to occur in measurements.

The declared vibration emission value and its uncertainty measured in accordance with EN ISO 28927-2, is as follows:

- The declared vibration emission value $a_{hd} = 1.10 \text{ m/s}^2$ and its uncertainty $K = 1.50 \text{ m/s}^2$
- The declared vibration total value has been measured in accordance with a standard test method and may be used for comparing one tool with another.
- The declared vibration total value may also be used in a preliminary assessment of exposure
- The vibration emission during actual use of the tool can differ from the declared total value depending on the ways in which the tool is used

Identify safety measures to protect the operator that are based on an estimation of exposure in the actual conditions of use (taking account of all parts of the operating cycle such as the times when the tool is switched off and when it is running idle in addition to the trigger time).



FREE SERVICES*

- User safety training upon receipt of merchandise
- Semi-Annual user safety training on request
- Annual safety seminar on appointment
- Loaner tools in event of product failure within 24 hours
- Torque/Tension consultation/seminar
- Half-Day, first-use supervision
- User training for first-time rentals
- Warranty repairs including return-freight
- Annual product inspection on request
- Product demonstrations
- 1-year hassle-free warranty
- Upgrades during the lifetime of the tool to enhance safety, durability, and function

***Above services are not subject to travel expense charges.**

REPAIRS

- All repairs are guaranteed for 6 months.
- All repairs are subject to labor and part cost as outlined in the official HYTORC price list.
- All repairs will be tested and calibrated to ensure the highest quality repairs.
- All warranty repairs are free of all charges including return-freight.

TOOL RENTALS

- 100% of all paid rentals will be applied as a discount towards any new purchase in that calendar year
- User training for first-time rentals is free of all cost
- Rental tools are guaranteed to perform and are subject to the free loaner tool policy of HYTORC

HELP

If you require any further assistance, please call your local HYTORC Representative or 1-800-FOR-HYTORC (1-800-367-4986). Please visit us at HYTORC.com.

Warranty

The jGun has a 1-year hassle-free warranty. Every HYTORC tool is tested before leaving the factory and is warranted to be free from defects in workmanship and materials. HYTORC will repair or replace, without charge, any tool which upon examination proves to be defective in workmanship or materials for one (1) year after the date of purchase. This warranty does not cover damage from repairs made or attempted by other than HYTORC authorized repair facilities.

The repair and replacement remedies described herein are exclusive. In no event shall HYTORC be liable for any incidental, special, or consequential damages, including loss of profits. This warranty is exclusive and in lieu of all other warranties or conditions, written or oral, expressed or implied for merchantability or fitness for particular use or purpose.

This warranty gives you specific legal rights. You may also have other rights that vary from state to state and province to province. In those states that do not allow the exclusion of implied warranties or limitation of incidental or consequential damages, the above limitations or exclusions may not apply to you.

If you have questions about the HYTORC warranty, contact our customer service center at 201-828-5270.

HYTORC

120 Wesley Street, Hackensack, New Jersey 07606 U.S.A.

Tel: 201-828-5270 • E-Mail: info@hytorc.com • Web: www.hytorc.com

jGun Overview

The jGun pneumatic torque wrench is designed to safely and accurately deliver up to 8,000 ft-lbs of torque onto a fastener. This is accomplished using a patented planetary gearbox torque multiplier system and an appropriate reaction arm or HYTORC Reaction Washer™ and HYTORC Nut™. The torque multiplier produces torque ratios of up to 1450:1 while the reaction arm or washer is used to absorb the high counter rotational force produced as the final torque value is reached. At final torque value, the jGun safely stalls out, leaving the fastener tightened to specification.

Unlike impact wrenches, the jGun never transmits working torque to the operator. The torque is applied between the fastener and the reaction surface.

This manual provides information for both the standard jGun® SINGLE SPEED and the jGun® DUAL SPEED.

jGun SAFETY

Only qualified personnel who have thoroughly read this document may operate this tool. Failure to safely operate this tool may result in serious injury or death.

- Inspect all jGun components as they are removed from the shipping container. If damage is found to any component, contact your shipper immediately. Do not use the tool.
- Failure to follow correct tool usage could result in personal injury, co-worker injury, and/or damaged tools and equipment.
- Ensure your working area is clean and unobstructed before beginning work.
- jGun maintenance and repair must be performed by a qualified pneumatic technician.
- Modifying a jGun or jGun accessory is dangerous and invalidates the warranty.
- Inspect the tool before each use. Replace any obviously worn or damaged parts.
- When not in use, store the jGun and jGun accessories in the plastic storage case supplied with the tool. Do not expose the gun to high humidity or large temperature variations.

Personal Protective Equipment

- Always wear the appropriate personal protective equipment when operating a jGun including gloves, safety goggles, hearing protection, hard hat, and safety shoes.

Air Supply Requirements

- The air supply line must be ½-inch minimum diameter to allow adequate air flow to the jGun.
- The air supply must provide a minimum of 90 psi at 30 cfm.
- Ensure that air line fittings are tight and leak free. Do not over tighten air line fittings.
- Always use the Filter Regulator Lubricator (FRL) Unit provided with the jGun. Never use a substitute oiler and regulator.

NOTE

Set the air pressure at the FRL while the tool is running as described in FRL Setup and Use.

- Open the air supply connected to the FRL unit and run the jGun while setting the pressure on the regulator gauge.
- Set the air pressure to the PSI needed to achieve desired torque shown on the provided pressure/torque conversion chart, also shown in Pressure / Torque Conversion Charts.

THE NEW PATENTED SAFETY LEVER

This patented safety mechanism drastically reduces the chance for operator error which can lead to safety risks.

The lever must be depressed while pulling the trigger, thereby ensuring that the tool operator keeps hands away from pinch points.



Reaction Arm or HYTORC Washer

Choose the correct reaction arm for the job. The jGun is shipped with a standard length reaction arm, but your gun may have been ordered with a custom reaction arm for a specific purpose.

Figure 1. Reaction Arm



The HYTORC Washer system can be used for all applications instead of reaction arm.

Figure 2. HYTORC Washer and Driver



WARNING!

Never modify a reaction arm! Changes in the reaction arm may lead to personal injury or damage to the tool.

NOTE:

Reaction arm modifications result in loss of warranty for the reaction arm and the jGun. If you need a custom reaction arm, please consult with your local HYTORC dealer.

Reaction Arm and Socket Installation

- Choose the correct reaction arm for the job. The jGun is shipped with a standard length reaction arm, but your gun may have been ordered with custom-length reaction arm for a specific purpose.
 - If using the HYTORC Washer, follow installation instructions in HYTORC Washer Overview.
 - Clean the reaction arm and jGun barrel mating surfaces before installing the reaction arm.
 - Slide the reaction arm onto the jGun barrel with the reaction arm extension facing out.

Figure 3. Installing a Reaction Arm

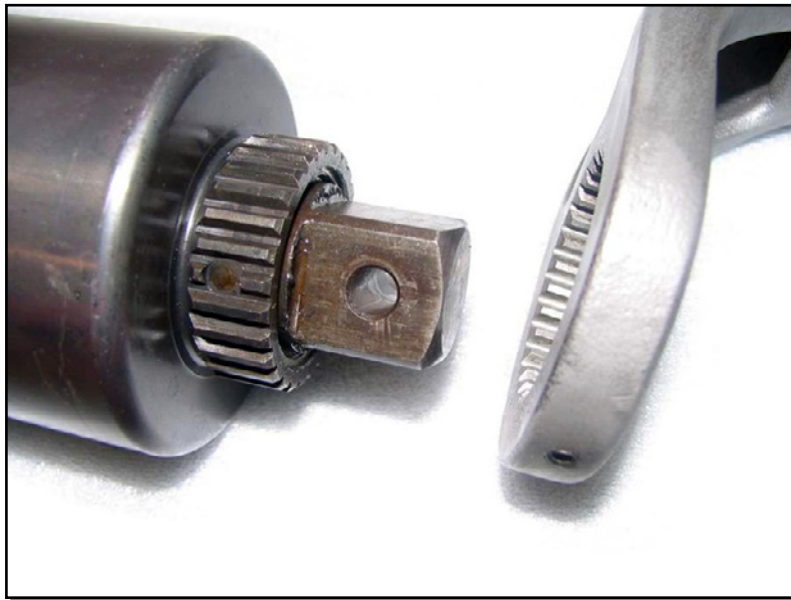

!! CAUTION !!

ALWAYS INSTALL THE REACTION ARM WITH THE EXTENSION FACING AWAY FROM THE GUN.

FAILURE TO INSTALL THE REACTION ARM CORRECTLY COULD RESULT IN THE REACTION ARM COMING IN CONTACT WITH YOUR HAND OR OTHER ANOTHER PART OF YOUR BODY, CAUSING PERSONAL INJURY.



Figure 4. Reaction Arm installed



- Lock the reaction arm to the jGun by aligning the set-screw with the hole in the splined section and then tightening the set screw firmly.

Figure 5. Tightening Reaction Arm Set Screw



- Place the appropriately sized socket onto the jGun barrel.

Figure 6. Installing jGun Socket



- Install the socket locking pin and retaining ring.

Figure 7. Installing Socket Locking Pin and Retaining Ring



Key Operating Safety Points

- Ensure that the reaction arm is in direct contact with an appropriate immovable object before beginning to tighten the fastener.

Figure 8. Placement of Reaction Arm

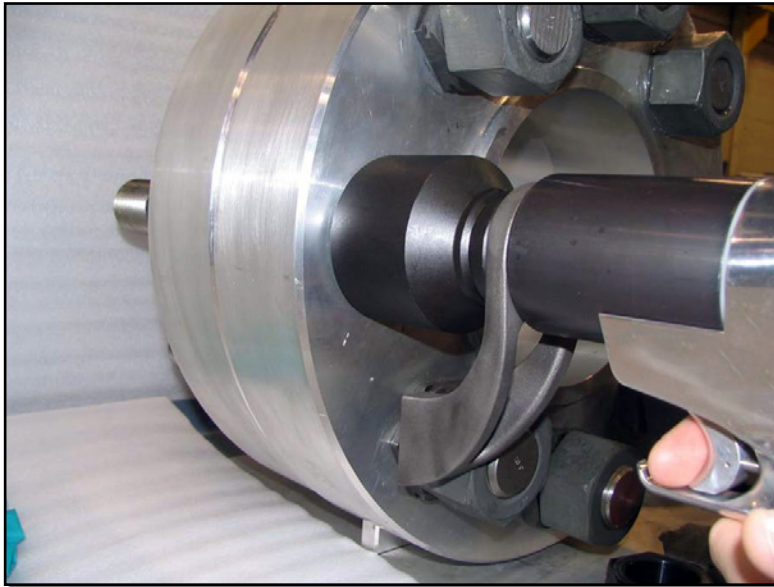

- Using the HYTORC Washer eliminates external moving parts and increases worker safety. Refer to HYTORC Reaction Washer Overview.



!! CAUTION !!

FAILURE TO HAVE THE REACTION ARM IN DIRECT CONTACT WITH AN APPROPRIATE IMMOVABLE OBJECT BEFORE BEGINNING TO TIGHTEN THE FASTENER COULD RESULT IN LOSS OF CONTROL OF THE TOOL AND PERSONAL INJURY.

- Keep all body parts clear of the reaction arm and reaction arm contact point (immovable object).



!! CAUTION !!

DO NOT PLACE ANY PART OF YOUR BODY BETWEEN THE REACTION ARM AND AN APPROPRIATE IMMOVABLE OBJECT AT ANY TIME WHILE A FASTENER IS BEING IS BEING TORQUED.

PERSONAL INJURY MAY OCCUR IF ANY PORTION OF YOUR BODY IS LOCATED BETWEEN THE REACTION ARM AND THE IMMOVABLE OBJECT WHEN THE FASTENER IS BEING TORQUED.

- Ensure the jGun barrel is in a straight line with relation to the stud and that the socket is fully engaged onto the fastener.
- As the tool takes up the bolt load, the jGun may shift.

jGun SETUP AND USE

Proper setup and use of the jGun before and during installation ensures accurate results and safe operation. The FRL Unit provided with the jGun must be used with the hose provided to ensure the tool's durability. See the FRL Unit Overview section below for more information.

Setting a Torque Value

1. Determine the torque value for the fastener to be tightened, as shown in the Bolt Torque Specifications table below.

Table 1 - Bolt Torque Specifications

SAE1 SAE2 30,000PSI	ASTM 193 Grade B7 Bolt	Gr. 7 A/F Heavy Hex Nut	FootPounds	Estimated Load
1 inch	7/8 inch	1-7/16 inches	300	18,150 lbf
1-1/8 inches	1 inch	1-5/8 inches	425	23,690 lbf
1-1/4 inches			600	29,955 lbf
1-3/8 inches	1-1/8 inches	1-3/16 inches	700	36,990 lbf
	1-1/4 inches	2 inches	800	46,776 lbf
1-1/2 inches			900	44,760 lbf
1-5/8 inches	1-3/8 inches	2-3/16 inches	1,250	53,400 lbf
	1-1/2 inches	2-3/8 inches	1,500	64,617 lbf
1-3/4 inches			1,600	62,400 lbf
1-7/8 inches			1,800	72,300 lbs
	1-5/8 inches	2-9/16 inches	2,000	76,540 lbs
2 inches			2,200	83,100 lbs
	1-3/4 inches	2-3/4 inches	2,600	89,440 lbs
2-1/4 inches			3,000	106,800 lbs
	1-7/8 inches	2-15/16 inches	3,700	110,680 lbs
2-1/2 inches	2 inches	3-1/8 inches	4,000	133,200 lbs
2-3/4 inches			5,100	162,900 lbs
	2-1/4 inches	3-1/2 inches	6,000	168,200 lbs
3 inches			7,000	195,300 lbs
	2-1/2 inches	3-7/8 inches	8,000	213,120 lbs
3-1/4 inches			9,000	230,700 lbs
3-1/2 inches	2-3/4 inches	4-1/4 inches	10,000	268,800 lbs
3-3/4 inches	3 inches	4-5/8 inches	13,000	310,200 lbs
4 inches			14,500	354,000 lbs
	3-1/4 inches	5 inches	16,500	369,120 lbs
4-1/4 inches			19,500	401,400 lbs

NOTE: The Data Above is based on bolts lubricated to manufacturer's specifications. Due to a variation in friction, HYTORC recommends in extreme cases to check with the bolt manufacturer, as the chart represents a guideline only.

2. Determine the air pressure needed to achieve the desired torque by consulting the Pressure/Torque Conversion Chart provided with each tool.
3. Open the air supply connected to the FRL unit and run the torque wrench while setting the pressure on the gauge.

NOTE

The torque wrench must be running while the pressure is being set. When the torque wrench is stopped, the gauge displays a slightly higher pressure than was set with the jGun running. This is normal, proper torque is delivered under working load.

Changing the Drive Direction

1. To change the square drive direction from forward to reverse or vice versa.
2. Move the directional lever on the back cover to the left (Tighten) or right (Loosen).

Figure 9. jGun Drive Direction Lever



3. Be sure the lever is fully engaged in either direction before operating the gun.

Operating the jGun

To operate the jGun:

1. Place the correct size impact socket on the square drive and secure it with the locking pin and ring.
2. Ensure that the square drive is fully engaged into the socket.
3. Engage the socket onto the nut.
4. Make sure the socket is fully engaged onto the nut.
5. Ensure that the reaction arm is placed firmly against a stationary surface such as an adjacent nut, a flange, or equipment housing. (If using the HYTORC™ reaction washer in place of a standard reaction arm ensure that it is setup according to the steps in the HYTORC Reaction Washer Overview section.)
6. Apply momentary pressure to the torque wrench trigger to ensure proper socket engagement and reaction arm placement.

Figure 10. jGun Operation

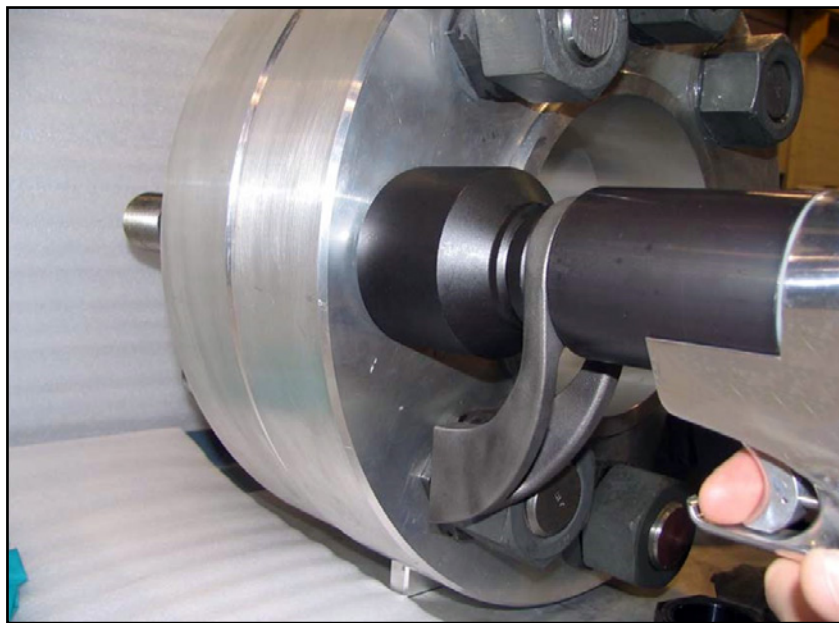

7. Torque the fastener by depressing the trigger until socket stops turning and air bypasses the motor.



!! CAUTION !!

BE SURE THE REACTION ARM IS FULLY ENGAGED AND LOCATED ON A SOLID, SECURE REACTION POINT. FOR ADDED SAFETY, REMAIN CLEAR OF THE REAR OF THE REACTION ARM DURING OPERATION. ALSO, WHEN INITIALLY APPLYING THE TOOL, PRESSURIZE THE SYSTEM MOMENTARILY; IF THE TOOL TENDS TO RIDE UP OR CREEP, STOP AND READJUST THE REACTION ARM TO A MORE SOLID AND SECURE POSITION.

Loosening a Fastener

1. Set the FRL Pressure to max PSI as listed on Pressure/Torque Conversion Chart.
2. Fully engage the torque wrench socket on the nut.
3. Either place the reaction arm firmly against a stationary surface or engage the HYTORC Washer Driver over the reaction washer.

Figure 11. Using the jGun with a HYTORC Washer



4. Ensure the torque wrench is set to the loosening direction.
5. Remove the fastener.

jGun Repair and Maintenance

Although the FRL Unit keeps the jGun self-maintained by continuously provided pneumatic tool oil to the tool during operation, proper repair and preventative maintenance will ensure the full life span of your tool.

Maintaining Hoses and Fittings

- Visually inspect air lines and air line fittings before tool use
- Replace worn or leaking air lines
- Tighten leaky fittings



!! CAUTION !!

LOOSE FITTINGS CAN BE POTENTIALLY DANGEROUS WHEN PRESSURIZED. OVER TIGHTENING FITTINGS CAN CAUSE PERMANENT THREAD FAILURE.

LOOSE FITTINGS OR OVER TIGHTENED FITTINGS CAN CAUSE PERSONAL INJURY AND TOOL DAMAGE.

ENSURE THAT AIR LINE FITTINGS ARE TIGHT, BUT NOT OVERLY TIGHT.

Lubricating the Air Motor

To lubricate the air motor:

1. Turn the jGun upside down and disconnect the air hose at the hose coupling connection.
2. Pour approximately one ounce of air tool oil, or spray a lubricant, into the hose coupling on the gun.
3. Reconnect the hose and operate the gun, while standing clear of the exhaust opening at the base of the handle. Excess lubricant will release from this opening upon initial operation.

Calibration

HYTORC provides a pressure / torque conversion chart with every tool. The stated accuracy is +/- 5%. If you properly maintain your tool and keep it in good working condition, it will stay within this stated accuracy. Proper maintenance procedures can be found in this jGun Operations Manual.

If the torque required is for a critical application or if the torque output is in question, the torque accuracy or output of a tool can and should be verified through calibration. Calibration is available by HYTORC for a minimal fee.

For the latest torque conversion charts please visit our website: www.hytorc.com/pneumatic.

jGun® DUAL SPEED Pneumatic Torque Tool

The jGun® DUAL SPEED is another innovation of our pneumatic torque wrenches. It gives a user the ability to select between 2 speeds; high speed or maximum torque. Physically, the DUAL SPEED gun is identical to the DUAL SPEED jGun, with the exception of the clutch wheel located on the barrel of the gun which guides the shifting mechanism through a twisting action rather than the push and pull of the standard DUAL SPEED jGun.

Figure 12. jGun® DUAL SPEED



Shifting Between Modes

The DUAL SPEED gun has two settings: High Speed and Maximum Torque.

Figure 13. High Speed Setting (Left) and Maximum Torque Setting (Right)

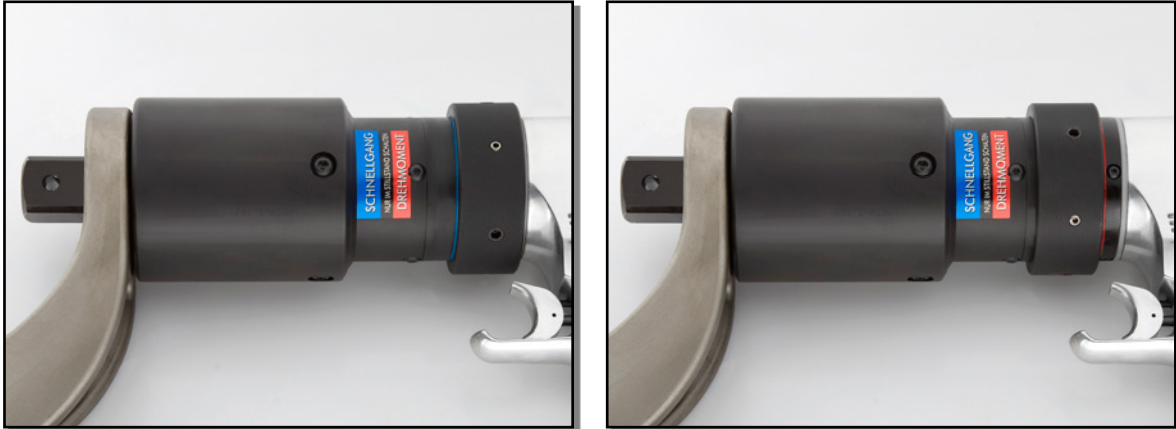

High Speed Setting (NEW STYLE SHIFTER COLLAR)

- To shift into high speed mode, push shifter collar down towards the nose of the gun and turn counter-clockwise

Maximum Torque Setting (NEW STYLE SHIFTER COLLAR)

- To return to Torque mode, simply turn the shifter collar clockwise



NOTE

NEVER SWITCH GUN MODES ON THE FLY. When shifting between High Speed and Maximum Torque modes, make sure the tool is stopped and fully engaged in either the forward or backward position. To ensure the shifter is fully engaged in “torque” the red line should be visible and when fully engaged in “run down” the blue line should be visible. ***If neither colored line is visible then the shifter is NOT fully engaged and the tool is NOT yet ready for use.*** You may need to jog the gun by gently pulling the trigger to disengage the clutch. Failure to fully engage tool may affect the operation of the tool and ultimately result in loss of control and/or damage to the tool.

Tool Operation

Before operating the tool, be sure to follow the safety precautions listed in the jGun Safety section on page 8.



!! CAUTION !!

KEEP LOOSE CLOTHING OR JEWELRY AWAY FROM THE TOOL AS LOOSE ITEMS MAY INTERFERE WITH TOOL WHILE IT IS IN MOTION AND POSSIBLY CAUSE INJURY. USE CAUTION AS REACTION ARM WILL ROTATE WITH GEAR BOX HOUSING UNTIL IN FIXED POSITION.

Operation with a Socket and Reaction Arm

Read this section carefully before proceeding.

Please refer to the instructions for Reaction Arm and Socket Installation.

PROCEDURE:

- Initially, attach the reaction arm and socket; tighten until all the nuts are run down to their desired position. During high speed operation the jGun® DUAL SPEED should be equipped with the reaction arm, locking pin, the retaining ring, and the socket.
- To make sure the tool is set for High Speed operation, twist the collar while moving it backwards until it locks into position. Use the tool to run the nuts down the stud.
- Once the nuts are run down to their final position, twist the collar while moving it forward until it locks into position to set the tool into its Maximum Torque mode. Once engaged, the tool behaves in the same manner as the single speed tool.
- Remove the jGun socket and install the reaction arm as shown in Figure 18.
- Remember that the reaction arm must be locked with easy snap lock.
- After setting up the jGun® DUAL SPEED with a reaction arm, torque the nuts to the desired load.



!! CAUTION !!

REMEMBER, A REACTION ARM SHOULD ALWAYS BE USED WITH THE DUAL SPEED GUN WHEN IT IS IN ITS HIGH SPEED MODE. FAILURE TO COMPLY WITH THIS WARNING MAY RESULT IN INJURY AS THE TOOL MAY SPIN OUT OF CONTROL AND POSSIBLY CAUSE PHYSICAL INJURY.

Operation with a HYTORC Washer

- The HYTORC Washer socket should be removed from the jGun until the nuts are spun down to the correct depth. During high speed operation the jGun® DUAL SPEED should only be equipped with the locking pin, the retaining ring, and socket.
- Place the tool in its High Speed Mode and spin the HYTORC Washer down to the desired position. After completing this, run the standard nuts down until they reach the HYTORC Washer already in place in the stud.
- Install the HYTORC Washer socket driver assembly provided. Refer to the HYTORC Washer Reaction Washer Overview for any further questions about setup.
- Once the HYTORC Washer socket driver assembly is properly installed, place the jGun over the nut and HYTORC Washer and tighten until operator reaches the desired torque.

Filter/Regulator/Lubricator (FRL) UNIT Overview

A Filter/Regulator/Lubricator (FRL) Unit is provided with every jGun and must be used in conjunction with the tool. In addition, the FRL Unit must be used with the 12' hose provided for connection to the jGun to ensure the tool's durability. The FRL Unit removes water and foreign material from your air supply, regulates the air pressure, and mixes pneumatic tool oil into the air to keep your jGun lubricated.

Operating the jGun without the FRL Unit will void the warranty and may cause damage to the air motor and gearbox. Incorrect setting of the lubricator unit may result in a shortage of lubrication to the air motor and gearbox resulting in damage to the tool.

Figure 14. FRL Unit (Shown without silencer)

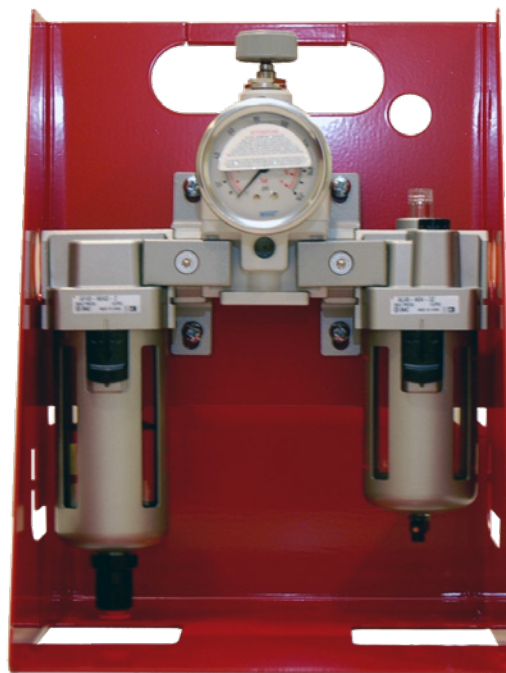

FRL Safety

Only qualified personnel who have thoroughly read this document may operate this tool. Failure to safely operate this tool may result in serious injury or death.

- Inspect all FRL components as they are removed from the shipping container. If damage is found to any component, contact your shipper immediately. Do not use the tool.
- Failure to follow correct tool usage could result in personal injury, co-worker injury, and/or damaged tools and equipment.
- Ensure that your working area is clean and unobstructed before beginning work.

- FRL maintenance and repair must be performed by a qualified pneumatic technician.
- Modifying an FRL or FRL accessory is dangerous and invalidates the warranty.
- Inspect the unit before each use. Replace any obviously worn or damaged parts.
- When not in use, properly store the FRL, hoses and couplers.
- Analog gauges are standard to our FRL units. Digital gauges are not recommended for certain applications. Please consult a Technical Representative before using a digital gauge unit.

Personal Protective Equipment

- Always wear the appropriate personal protective equipment when operating the FRL and jGun including gloves, safety goggles, hearing protection, hard hat, and safety shoes

Air Supply Requirements

- Air supply line must be ½-inch minimum diameter to allow adequate air flow to the jGun
- Air supply must be 90 psi @ 30 cfm minimum.
- Ensure that air line fittings are tight and leak free. Do not over tighten air line fittings.
- Always use the FRL Unit provided with the jGun. Never use a substitute oiler and regulator with a jGun.
- Open the air supply connected to the FRL unit and run the torque wrench while setting the pressure on the gauge.
- Set the air pressure to the PSI needed to achieve desired torque shown on the provided pressure/torque conversion chart.

NOTE

Set the air pressure while the tool is running as described in the Setup and Use section.

- Open the air supply connected to the FRL unit and run the torque wrench while setting the pressure on the gauge.
- Set the air pressure to the PSI needed to achieve desired torque shown on the provided pressure/torque conversion chart.

FRL SETUP AND USE

Proper setup and use of the FRL unit will ensure accurate results and safe operation. The three components of the FRL must be checked individually to ensure correct operation.

- Empty the filter reservoir before use.
- Adjust the lubricator flow properly.
- Fill the lubricator reservoir with pneumatic tool oil (provided with the FRL unit).

Important FRL Operating Procedures

- Only operate the unit with the air flow moving in the direction indicated by the arrows on top of the unit.
- Empty the filter reservoir before each use to remove water and sediment.
- Fill the lubricator reservoir only with pneumatic tool oil before each use.
- Adjust the lubricator flow to one (1) drop per ten (10) seconds (shortage of lubrication may cause motor to seize).
- Use only the hose provided with the FRL for connection to the unit; a change in hose length may affect tool durability and accuracy. Using a different length hose is only recommended after re-calibration of the tool with the desired length hose and after a new calibration certificate is issued.

Emptying the Filter Reservoir

You may empty the filter reservoir of water and foreign material in two ways:

- Emptying water through the release valve on the underside of the reservoir.
 - a. To use the release valve, push the valve until the water or debris drains out of the reservoir.
- Removal of the reservoir. To remove the reservoir from the FRL unit:
 - a. Push down on the black square button to unlock the reservoir.
 - b. Twist the filter reservoir until the two lines on the FRL body and the filter reservoir are aligned.

Figure 15. Emptying the FRL Filter Reservoir



- c. Pull the filter reservoir down to detach from lubricator body.
- d. Discard the contents of the filter reservoir.

Figure 16. Detaching FRL Reservoir



Figure 17. FRL Unit – Lubricator 2/3 Full of Oil

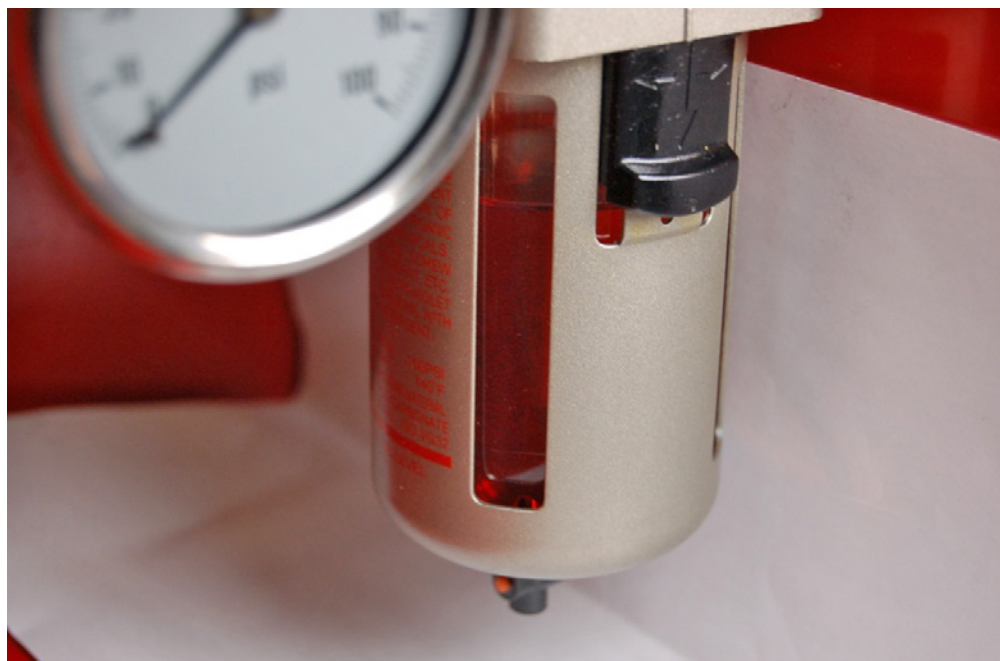

- e. If needed, refill the reservoir as described on page 21.
- f. Reattach the lubricator by aligning the lines on the filter reservoir and FRL body, and pushing up on the reservoir, then twisting the reservoir to lock it in place. The black locking button should snap into its original position.

Adjusting Air Pressure

To adjust the air pressure at the regulator:

1. If you are using a digital gauge, press the ON button on the gauge, then press the ZERO button to set the reading to zero. Do not press the ZERO button when the system is under pressure.
2. A Torque Chart is provided with each tool which gives the conversion from air pressure (PSI) to torque (ft-lbs and N-m). Use the chart to determine the air pressure needed to achieve desired torque output.
3. Connect your air supply to the FRL, and press the ON button to view current air pressure.
4. While operating the tool, turn the regulator knob clockwise to decrease pressure and counter-clockwise to increase pressure. Allow 30 seconds for the analog gauge to settle.
(Pressure Valve is regulated not to exceed 90 PSI)

Figure 18. Adjusting FRL Regulator

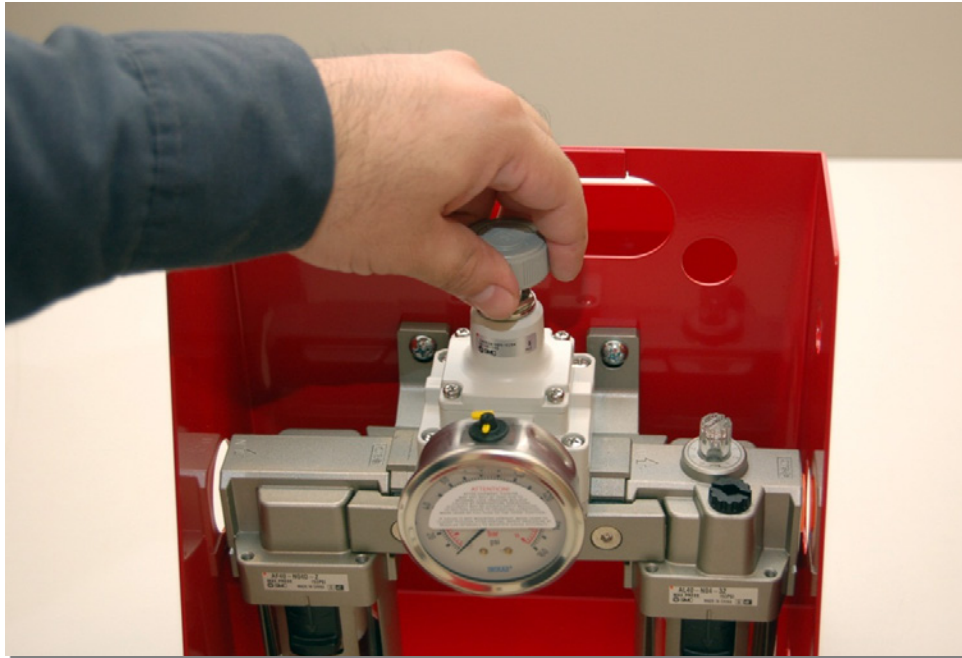

Filling the Lubricator Reservoir

To fill the lubricator reservoir:

1. Push the black square button down to unlock the reservoir.
2. Twist the lubricator reservoir until the two lines on the lubricator body and the lubricator reservoir are aligned.
3. Pull the lubricator reservoir down to detach it from lubricator body.
4. Pour pneumatic tool oil into the reservoir until it is about two-thirds full.
5. To reattach the lubricator, realign the lines on the lubricator reservoir and main body, then push the two pieces together and twist the reservoir to lock in place.

Adjusting the Flow

To adjust the oil flow of the FRL device:

1. Remove any attachments from the tool.
2. Run the tool while watching the rate at which oil drips through the acrylic view-glass on the lubricator unit.

Figure 19. Adjusting FRL Oil Flow

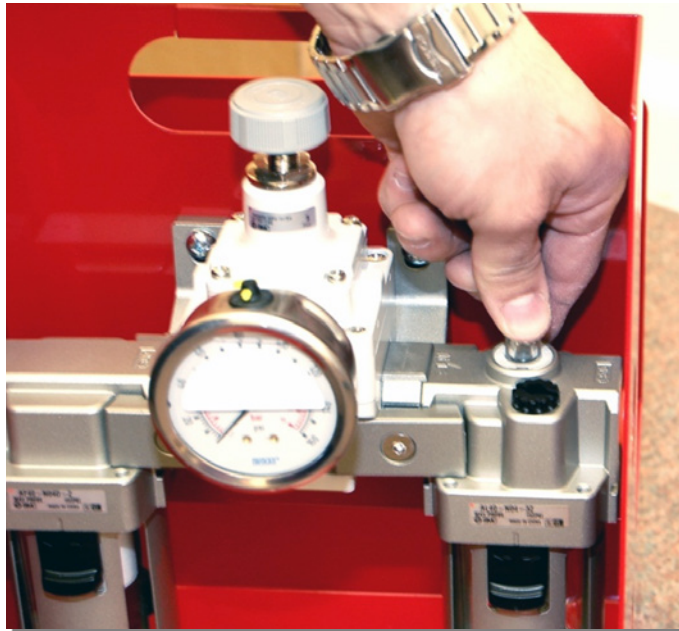

3. Turn the flow adjustment knob clockwise or counter-clockwise until the oil is dripping at a rate of at least one drop every ten seconds.

Repair and Maintenance

Although the FRL is a self-contained unit and does not require heavy maintenance, proper repair and preventative maintenance will ensure the life span of the unit.

Hoses and Fittings

- Visually inspect air lines and air line fittings before tool use.
- Replace worn or leaking air lines.
- Tighten leaky fittings



!! CAUTION !!

LOOSE FITTINGS CAN BE POTENTIALLY DANGEROUS WHEN PRESSURIZED. OVER TIGHTENING FITTINGS CAN CAUSE PERMANENT THREAD FAILURE. LOOSE FITTINGS OR OVER TIGHTENED FITTINGS CAN CAUSE PERSONAL INJURY AND TOOL DAMAGE. ENSURE THAT AIR LINE FITTINGS ARE TIGHT, BUT NOT OVER TIGHT.

Anti-Explosion Static Dissipative Hose

The jGun is certified to operate in a gas and dust explosive environment with the following rating:



The jGun is certified to operate in a gas and dust explosive environment when used with the with a special static dissipative hose as follows, (See Figure 20):

- Greater than 10ohm resistance equals failure
- Hose connection at air source inlet should be coupled to an earth ground to dissipate static electricity

To order use the following number code:

HYTORC P/N: JGUN-FRL HOSE ##-ATEX (Where ## = Hose Length (Ft.))

Figure 20. Static Dissipative Hose

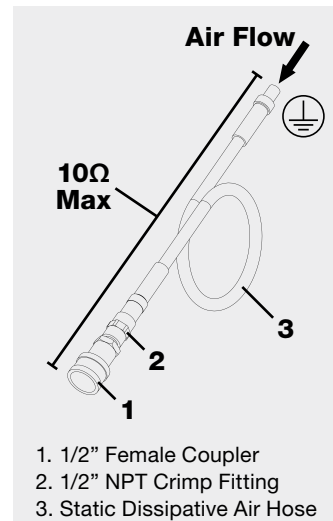

HYTORC Washer Overview

The HYTORC Washer makes having a Reaction Arm unnecessary. It is sold and distributed exclusively by HYTORC. The HYTORC Washer is a washer that fits under a standard nut and is used in conjunction with the HYTORC Washer Driver. The nut is driven by the inner sleeve of the drive. The reaction of the tool is transmitted to the outer sleeve of the HYTORC Washer drive.

Figure 21. HYTORC Washer and Driver



Safety increases as there are no external moving parts. The system provides a universal HYTORC reaction point for all applications, making custom reaction arms unnecessary. The fact that the tightening and the reaction takes place in the same axis, eliminates lateral forces, balances surface friction and increases bolt load accuracy.

Figure 22. HYTORC Washer Socket Mounted on jGun



Safety

Only qualified personnel who have thoroughly read this document may operate this system. Failure to safely install the HYTORC Washer may result in serious injury or death.

- Inspect all HYTORC Washer reaction washers as they are removed from the shipping container. If damage is found to any component, contact your shipper immediately. Do not use the washer.
- Failure to follow correct tool usage could result in personal injury, co-worker injury, and/or damaged tools and equipment.
- Ensure that your working area is clean and unobstructed before beginning work.
- Modifying a HYTORC washer or accessory is dangerous and not recommended.
- Inspect the HYTORC Washer and HYTORC Washer driver before each use.
- Replace any obviously worn or damaged parts.
- When not in use, properly store the HYTORC Washer drivers and any unused HYTORC Washers.

Personal Protective Equipment

- Always wear the appropriate personal protective equipment when operating the FRL and jGun including gloves, safety goggles, hearing protection, hard hat, and safety shoes.

HYTORC Washer Requirements

- Always use the appropriately sized HYTORC Washer for the nuts and bolts you use.
- All specifications of the connection (screw size, material, seal type, etc.) must be coordinated.
- When installing the HYTORC Washer, use only original HYTORC accessories. Never use a wrench or other torque drive.

HYTORC Washer Assembly, Use and Service (SETUP)

Correct preparation and use of HYTORC Washers are a prerequisite for good rundown and for safe handling.

Important Preparation Steps for the HYTORC Washer

- Before using the HYTORC Washer the connection and the connection elements must be carefully checked and cleaned.
- The HYTORC Washer must be completely dry and free from oil and grease.
- The nut to be mounted above the HYTORC Washer must be lubricated according to the specifications and application requirements.

Important Installation Steps for the HYTORC Washer

- Slide bolts through the bolt hole.
- Determine which side of the connection is more suitable for fastening and tightening the bolts. (Working space for bolting, lighting, accessibility).
- Install the clean, dry nut on the opposite side from which you want to tighten.
- Install the HYTORC Washer on the side which you want to tighten by rotating the bolt clockwise until it is hand tight.
- Now install the lubricated nut (on the same side as the HYTORC Washer) by turning it clockwise until it is hand tightened against the HYTORC Washer.

Figure 23. HYTORC Washer Installed



CAUTION

For a correct installation only 3 to 4 threads should be seen beyond the nut to be tightened.

Once all the bolts are prepared following the previous instructions for assembly, tighten the nuts using the HYTORC Washer Driver.

Figure 24.
Aligning HYTORC Washer Socket Set Screw with Machined Recess in jGun Splines



8. Tighten the set screw.

Figure 25. Tightening HYTORC Washer Set Screw

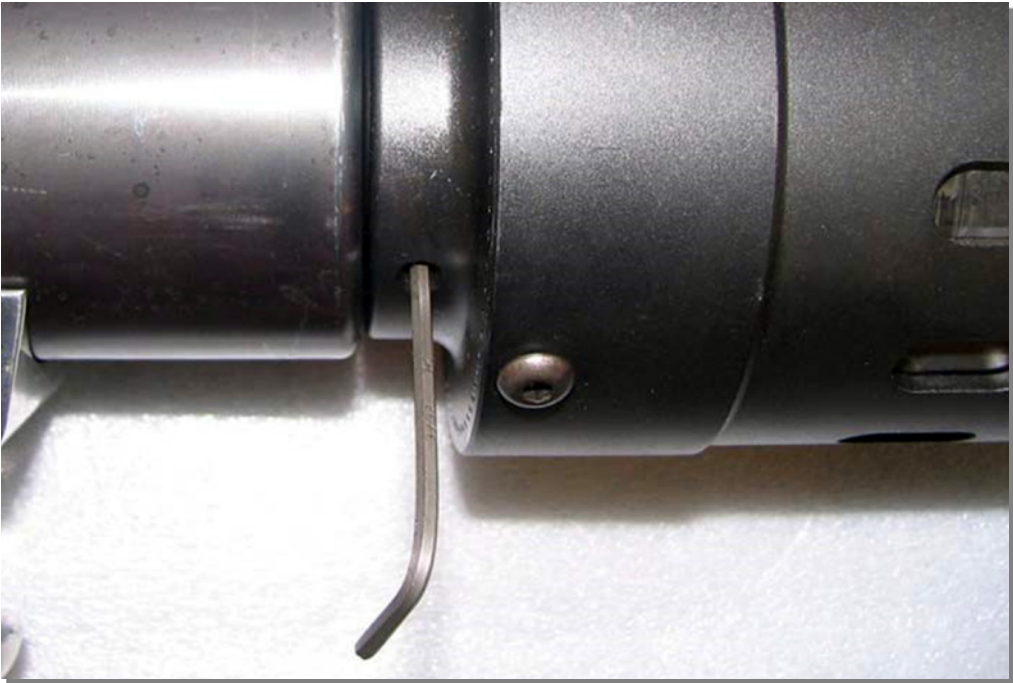

Tightening with the HYTORC Washer

- Put the tool in tightening mode.
- Put the tool in HYTORC Washer mode (Refer to the Options section)
- Place the HYTORC Washer Driver on the battery powered tool and tighten the set screw.
- Engage the HYTORC Washer Driver and tool with the nut by placing it over the top of the bolt to be tightened.
- Repeat the steps for tightening a bolt as shown for standard torque in this manual.

jGun Maintenance and Troubleshooting Tips

1. Only use your **jGun®** with a factory-specified FRL unit. The FRL unit is designed to filter out dirt, drain water and lubricate the air motor.
2. Always check and drain the water bowl on your FRL unit.
3. Always check and fill up the oil bowl on your FRL unit. Set the oil drip to one (1) drop every ten (10) seconds. Using your **jGun®** without oil will result in air motor damage. MARVEL AIR TOOL OIL is recommended.
4. Never exceed the maximum air pressure specified on the torque chart supplied with your **jGun®**.
5. Check the female coupler on your FRL unit's hose and the male coupler on your **jGun®** for dirt. Dirt entering your **jGun®** will result in air motor damage.
6. Before connecting an external air supply to your FRL unit, check the air pressure gauge and verify that it is set at "zero" pressure. A damaged air gauge will result in inaccurate torque.
7. Check the air hose for leaks. An air leak will result in inaccurate torque.
8. Check your **jGun®**'s gear box for loose or missing screws. DO NOT operate if any screws are loose or missing, or serious damage may occur. Use LOCTITE 262 on screws.
9. Check your **jGun®**'s back cover gasket for air leaks. An air leak will result in inaccurate torque.

Changelog

07/09/2019 - Back cover updated. For future-proofing all global locations have been removed from the back cover in favor of our HYTORC universe map.

04/06/2021 - General Safety information added, ISO Declaration standards removed.

10/2024 - Warranty information updated under Technical Certifications, page 8, and page 9.

MISSION STATEMENT



OUR MISSION IS TO OPTIMIZE SAFETY, QUALITY AND SCHEDULE IN INDUSTRIAL BOLTING THROUGH INNOVATIVE SOLUTIONS AND AN UNYIELDING COMMITMENT TO WORLD CLASS CUSTOMER SERVICE.

WITH OVER 50 YEARS OF EXPERIENCE FOCUSED ENTIRELY ON DEVELOPING THE HIGHEST QUALITY INDUSTRIAL BOLTING SYSTEMS, HYTORC IS THE MOST TRUSTED NAME IN THE INDUSTRY.



Headquarters:

333 Route 17 N.,
Mahwah, NJ 07430
+1-201-512-9500

Contact:

1-800-FOR-HYTORC
info@hytorc.com

Online:

hytorc.com

Follow: