

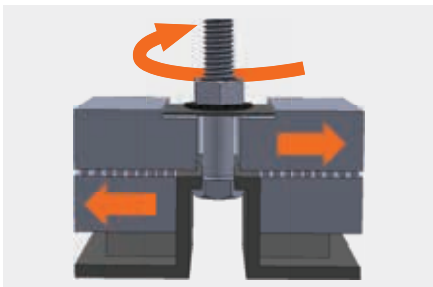

HYTORC J-WASHER

The new HYTORC J-Washer takes the HYTORC Reaction Washer to an entirely new level by adding a locking feature that minimizes loosening to keep bolts tight under dynamic loads. With the strategic placement of a ridge band on the surface, the new reaction washer prevents loosening of pre-loaded fasteners while providing all the benefits of the traditional HYTORC Reaction Washer including safety, speed and tool longevity.

ANTI-LOOSENING



Standard pre-loaded fasteners can loosen as a result of relative motion between surfaces due to vibration. The J-Washer's knurled surface locks the nut when torque is applied so that no loosening occurs. The locking design has been verified by the industry standard Junker test, which simulates the transverse forces that loosen the assembly.

SAFETY



The J-Washer provides outer reaction lobes that safely engage with a socket driver or reaction plate to brace the reaction forces during torque operations. Consistent with the standard HYTORC Reaction Washer, the new J-Washer eliminates the need for a separate reaction arm, eliminating pinch points and significantly reducing the risk of hand injury.

EFFICIENCY



The J-Washer's unique design locks the fastener assembly during tightening. When used in combination with a HYTORC Torque Tool, the J-Washer provides unmatched efficiency in bolting operations and reduced job time.

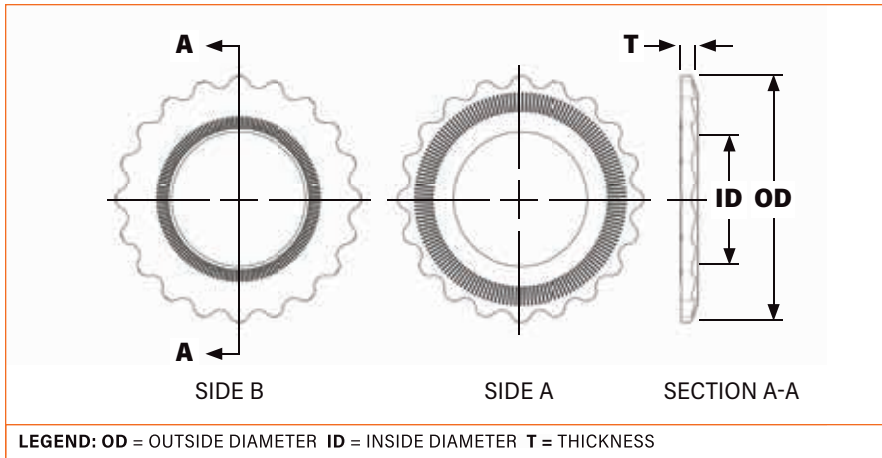

PART DESIGNATION

JRW-XXX-YY-Z

Part Number

Finish Code*

Material Code*

*Are used when alternative coatings and materials are specified.

HYTORC J-Washers are manufactured from AISI 4140 low alloy steel, hardened and tempered for superior strength, and finished with black oxide for corrosion protection. HYTORC J-Washers are suitable for harsh structural and industrial applications.

For standard washers use the Part Number from the tables below. Finish Code and Material Code shall be omitted from standard washer Part Numbers.

Additional coatings and materials are available upon request. Please contact HYTORC to specify the Part Number, Finish Code and Material Code for alternative coatings and materials.

NOMINAL LOCKING WASHER DIMENSIONS (IMPERIAL)**

BOLT SIZE	PART NUMBER	ID	OD	T
1/2"	JRW-008	0.531	1.118	0.123
9/16"	JRW-009	0.625	1.219	0.123
5/8"	JRW-010	0.688	1.432	0.130
3/4"	JRW-012	0.813	1.600	0.152
7/8"	JRW-014	0.938	1.865	0.152
1"	JRW-100	1.063	2.057	0.158
1-1/8"	JRW-102	1.241	2.307	0.190
1-1/4"	JRW-104	1.346	2.492	0.190
1-3/8"	JRW-106	1.497	2.742	0.190
1-1/2"	JRW-108	1.592	2.928	0.190
1-5/8"	JRW-110	1.703	3.179	0.245
1-3/4"	JRW-112	1.823	3.355	0.245
1-7/8"	JRW-114	1.977	3.617	0.245
2"	JRW-200	2.135	3.787	0.245
2-1/4"	JRW-204	2.341	4.280	0.298

NOMINAL LOCKING WASHER DIMENSIONS (METRIC)**

BOLT SIZE	PART NUMBER	ID	OD	T
M14	JRW-M14	15.00	28.40	3.10
M16	JRW-M16	17.00	30.96	3.10
M18	JRW-M18	19.00	36.37	3.30
M20	JRW-M20	21.00	37.01	3.30
M22	JRW-M22	23.00	40.64	3.30
M24	JRW-M24	25.00	47.37	4.10
M27	JRW-M27	28.00	52.25	4.10
M30	JRW-M30	31.00	58.60	4.80
M33	JRW-M33	34.00	63.30	4.80
M36	JRW-M36	37.00	69.65	4.80
M39	JRW-M39	40.00	74.37	4.80
M42	JRW-M42	43.00	80.75	6.40
M45	JRW-M45	46.00	85.22	6.40
M48	JRW-M48	50.00	91.87	6.40
M52	JRW-M52	54.00	96.19	6.40
M56	JRW-M56	58.00	108.71	7.60

J R W - 1 0 2

J-WASHER 1-1/8" BOLT SIZE, AISI 4140, BLACK OXIDE

J R W - M 3 0

J-WASHER M30 BOLT SIZE, AISI 4140, BLACK OXIDE

**All dimensions are for reference only.

HYTORC owns all content, copyrights, trademarks and patents in this document. © 2022 HYTORC. Any unauthorized use or distribution of any material from this document is strictly prohibited.



Headquarters:
333 Route 17 N., Mahwah, NJ 07430
+1-201-512-9500

Email:
info@hytorc.com

Phone:
1-800-FOR-HYTORC

Online:
hytorc.com